



The United Nations
University



ORKUSTOFNUN

Lectures on geothermal drilling and direct uses

By

HAGEN M. HOLE

Geothermal Consultants New Zealand Ltd.

P.O. Box 34391, Birkenhead

Auckland

NEW ZEALAND

**United Nations University
Geothermal Training Programme**

2006 - Report 3

Published in March 2007



The United Nations
University

GEOHERMAL TRAINING PROGRAMME
Orkustofnun, Grensásvegur 9,
IS-108 Reykjavík, Iceland

Reports 2006
Number 3

LECTURES ON GEOTHERMAL DRILLING AND DIRECT USES

Hagen M. Hole

Geothermal Consultants New Zealand Ltd.
P.O. Box 34391, Birkenhead
Auckland
NEW ZEALAND
(gcnzl@ihug.co.nz)

Lectures on geothermal drilling given in September 2006
United Nations University, Geothermal Training Programme
Reykjavík, Iceland
Published in March 2007

ISBN – 978-9979-68-211-0

PREFACE

The UNU Visiting Lecturer 2006 was Mr. Hagen Hole, Managing Director, Geothermal Consultants (NZ) Ltd., from New Zealand. He is one of the world's leading consultants in geothermal drilling engineering, and has worked for many years in Ethiopia, Kenya and Indonesia and a dozen other countries. He gave a series of lectures on advanced drilling technology (e.g. on aerated fluids for drilling geothermal wells, directional drilling, and drilling services contracts). He furthermore gave his audience a clear insight into what it is like to live and work for periods of many years in different countries with different cultures. His lectures were excellent and very well attended by members of the geothermal community in Iceland as well as the UNU Fellows and MSc Fellows.

Since the foundation of the UNU-GTP in 1979, it has been customary to invite annually one internationally renowned geothermal expert to come to Iceland as the UNU Visiting Lecturer. This has been in addition to various foreign lecturers who have given lectures at the Training Programme from year to year. It is the good fortune of the UNU Geothermal Training Programme that so many distinguished geothermal specialists have found time to visit us. Following is a list of the UNU Visiting Lecturers during 1979-2006:

1979 Donald E. White	United States	1993 Zosimo F. Sarmiento	Philippines
1980 Christopher Armstead	United Kingdom	1994 Ladislaus Rybach	Switzerland
1981 Derek H. Freeston	New Zealand	1995 Gudm. Bødvarsson	United States
1982 Stanley H. Ward	United States	1996 John Lund	United States
1983 Patrick Browne	New Zealand	1997 Toshihiro Uchida	Japan
1984 Enrico Barbier	Italy	1998 Agnes G. Reyes	Philippines/N.Z.
1985 Bernardo Tolentino	Philippines	1999 Philip M. Wright	United States
1986 C. Russel James	New Zealand	2000 Trevor M. Hunt	New Zealand
1987 Robert Harrison	UK	2001 Hilel Legmann	Israel
1988 Robert O. Fournier	United States	2002 Karsten Pruess	USA
1989 Peter Ottlik	Hungary	2003 Beata Kepinska	Poland
1990 Andre Menjoz	France	2004 Peter Seibt	Germany
1991 Wang Ji-yang	China	2005 Martin N. Mwangi	Kenya
1992 Patrick Muffler	United States	2006 Hagen M. Hole	New Zealand

With warmest wishes from Iceland

Ingvar B. Fridleifsson, director, UNU-GTP

TABLE OF CONTENTS

	Page
LECTURE 1: AERATED FLUIDS FOR DRILLING OF GEOTHERMAL WELLS	1
ABSTRACT	1
1. INTRODUCTION	1
2. HISTORY	1
3. BENEFITS	2
3.1 Drilling processes	2
3.2 Formation and resource	3
3.3 Cuttings return	3
3.4 Drilling materials	3
3.5 A fishing tool	3
3.6 Well recovery	4
4. DISADVANTAGES	4
4.1 Cost	4
4.2 Non-productive time activities	4
4.3 Potential dangers	4
4.4 Drill bit life	5
5. THE PROCESS	5
6. EQUIPMENT	7
6.1 General equipment	7
6.2 Rig equipment	8
6.3 Downhole equipment	9
7. ENVIRONMENTAL IMPACT	10
8. THE COSTS	10
ACKNOWLEDGEMENTS	11
REFERENCES	12
LECTURE 2: DIRECTIONAL DRILLING OF GEOTHERMAL WELLS	13
ABSTRACT	13
1. INTRODUCTION	13
2. THE DIRECTIONAL DRILLING PROCESS	14
3. LIMITATIONS	16
4. PROXIMITY OF OTHER WELLS	17
5. MULTI-WELL PADS	18
6. AN EXAMPLE OF A MULTI-WELL PAD – MOKAI, NEW ZEALAND	18
7. DRILLING CELLAR OPTIONS	20
ACKNOWLEDGEMENTS	20
REFERENCES	20
LECTURE 3: GEOTHERMAL WELL DRILLING SERVICES CONTRACTS	21
ABSTRACT	21
1. INTRODUCTION	21
2. COMPONENTS OF A GEOTHERMAL DRILLING OPERATION	21
3. GEOTHERMAL OWNERS RISKS	22
4. RESPONSIBILITY, CONTROL AND RISK	22
5. THE COST OF OPERATIONAL RISK	23
6. DOWNHOLE RISK	23
7. RESOURCE RISK	24
8. CONSEQUENTIAL RISK	24
9. FINANCIAL RISK	24
10. AN OWNER'S RISK	24
11. OBSERVATIONS	25
REFERENCES	25

	Page
LECTURE 4: GEOTHERMAL GREENHOUSE HEATING AT OSERIAN FARM, LAKE NAIVASHA, KENYA by Bruce Knight, Hagen M. Hole and Tracy D. Mills ...	27
ABSTRACT	27
1. INTRODUCTION	27
2. WELL CHARACTERISTICS	28
3. HEATING SYSTEM DESIGN FEATURES	29
3.1 Regulation of process nature.....	29
3.2 Fluid venting.....	30
3.3 Heat exchangers.....	31
3.4 Condensate & non-condensable gases separation.....	31
3.5 Fluid disposal.....	31
3.6 Control system.....	31
3.7 Mechanical design aspects.....	32
4. CONCLUSION	32
ACKNOWLEDGEMENTS	32
BIBLIOGRAPHY	32

LIST OF FIGURES

1. 1 Typical formation pressures.....	5
1. 2 Typical downhole pressures.....	6
1. 3 Annular pressure and formation pressure vs. depth	6
1. 4 Differential pressure vs. depth	6
1. 5 Annular velocity vs. depth	7
1. 6 Liquid volume fraction vs. depth	7
1. 7 Aerated drilling air compression equipment schematic layout	8
1. 8 Aerated drilling standpipe manifold schematic	8
1. 9 Aerated drilling wellhead, blooie line, and separator schematic.....	9
2. 1 ‘J’ shape well	14
2. 2 ‘S’ shape well.....	14
2. 3 Well MK-11 vertical section.....	15
2. 4 Well MK-11 plan	15
2. 5 Well MK-14 vertical section.....	16
2. 6 Well MK-14 plan	16
2. 7 Typical rotary build assembly.....	17
2. 8 Typical rotary “hold” assembly	17
2. 9 Typical rotary fall assembly.....	17
2. 10 Mokai well pad MK-II	19
2. 11 Wellhead locations on Mokai well pad MK-II	20
3. 1 Responsibility, control and risk matrix	22
4. 1 Extent of flow cycling.....	28
4. 2 P&ID for geothermal fluid sub-system.....	29
4. 3 P&ID for geothermal condensate and CO ₂ sub-system	30
4. 4 P&ID for greenhouse heating loop sub-system (at well site).....	30

LIST OF TABLES

1. 1 Comparison of thermal outputs of wells drilled with and without aerated fluids	3
1. 2 Simulation of aerated downhole conditions.....	6
1. 3 Typical cost breakdown of a geothermal well	11
1. 4 Aerated drilling services component cost breakdown.....	11
2. 1 Mokai well MK-11 directional drilling profile	15
2. 2 Mokai well MK-14 directional drilling profile	16
4. 1 Extent of flow cycling.....	28



LECTURE 1

AERATED FLUIDS FOR DRILLING OF GEOTHERMAL WELLS

ABSTRACT

The utilisation of aerated fluids for drilling geothermal wells allows for full circulation of drilling fluids and drilling cuttings back to the surface while drilling through permeable formations, thus significantly reducing the risk of the drill string becoming stuck, of formation and wellbore skin damage, and for full geological control. The technique, an adaptation of straight air drilling and foam drilling techniques utilised by the oil and geothermal drilling industries, was initially developed by a team from Geothermal Energy New Zealand Ltd. during the late 1970's and early 1980's. Since the initial development, the technique has been successfully utilised in many geothermal drilling programmes worldwide. Most recently, the technique was introduced into Iceland's geothermal drilling operations with remarkably successful results.

Keywords: geothermal, drilling, aerated drilling

1. INTRODUCTION

'Aerated Drilling' may be defined as the addition of compressed air to the drilling fluid circulating system to reduce the density of the fluid column in the wellbore annulus such that the hydrodynamic pressure within the wellbore annulus is 'balanced' with the formation pressure in the permeable 'loss zones' of a geothermal well.

2. HISTORY

Injecting compressed air into the mud circulating system to combat circulation losses while drilling for oil, was first carried out by Phillips Petroleum in Utah, USA in 1941. During the early 1970's, air or 'Dust Drilling' was introduced at the Geysers geothermal field in California, USA. Aerated drilling of geothermal wells was initially developed by Geothermal Energy New Zealand Ltd. (GENZL) during the period 1978 to 1982 while involved in drilling projects at the Olkaria Geothermal field in Kenya, and at the Kakkonda field in Honshu, Japan; and during the later part of this period GENZL developed its DOS based Air Drilling Simulation Package. Subsequent aerated geothermal drilling operations occurred at the following geothermal fields as listed below:

1982 – 1987:

- North East Olkaria – Kenya.
- Aluto-Langano – Ethiopia.

1987 – 1992:

- Nigorikawa, Hokaido – Japan.
- Sumikawa, Honshu – Japan.

- Darajat – Indonesia.
- Olkaria II and Eburru – Kenya.
- Los Humeros – Mexico.

1992 – 1997:

- Los Humeros – Mexico.
- Tres Virgenes – Mexico.
- Wayang Windu, Patuha and Salak, – Java, Indonesia.
- Ulumbu – Flores, Indonesia.

1997 – Present:

- Olkaria III – Kenya.
- Los Azufres – Mexico.
- Salak - Indonesia
- Ohaaki, Mokai, Rotokawa, Putauaki, Wairakei, and Tauhara – New Zealand
- Trölladyngja – Iceland
- Hellisheidi – Iceland.

3. BENEFITS

3.1 Drilling processes

The primary objective of utilising aerated drilling fluids is the ability to maintain drilling fluid circulation and therefore the clearance of cuttings from the hole as drilling proceeds. This continuous clearance of cuttings from the hole significantly reduces the risk of the drill string getting stuck in the hole. The majority of geothermal reservoir systems exist with a formation/system pressure which is significantly less than a hydrostatic column of water at any given depth within that system - in other words the reservoir systems are 'under-pressured'. When drilling into a permeable zone in such an 'under pressured' system, drilling fluid circulation is lost – the drilling fluid flows into the formation rather than returning to the surface. The traditional method of dealing with this situation was to continue drilling 'blind' with water – the pumped water being totally lost to the formation with the drilling cuttings being washed into the formation as well. The major problem with this method of drilling is that the cuttings rarely totally disappear into the formation. Stuck drill string due to a build up of cuttings in the hole, and well-bore skin damage being common occurrences.

A solution to these problems lies in the utilisation of reduced density drilling fluids. Aeration of the drilling fluid reduces the density of the fluid column and thus the hydraulic pressure exerted on the hole walls and the formation. As the introduced air is a compressible medium, the density of the column varies with depth – at the bottom of the hole where the hydrostatic pressure is greatest, the air component is highly compressed and therefore the density of the fluid is greatest; at the top of the hole, where the hydrostatic pressure is least, the air component is highly expanded and therefore the density of the fluid the least. The ratio of air to water pumped into the hole, and the back pressure applied to the 'exhaust' or flowline from the well, allows the down-hole pressures in the hole to be 'balanced' with the formation pressure in the permeable zones, thus allowing for the return of the drilling fluids to the surface and therefore maintaining drilling fluid circulation. (In fact the term 'under-balanced' drilling as applied to this form of geothermal drilling is a misnomer).

Initially the technique was utilised only in the smaller diameter production hole section of a well, however, in some fields permeability is prevalent in the formations located above the production zone, and significant amounts of lost time can be incurred in attempting to plug and re-drill such zones. Utilising aerated fluids to drill these zones has proven to be a highly successful solution.

3.2 Formation and the Resource

Perhaps the most important feature of aerated drilling is its effect on the productivity of the well. The removal of the drill cuttings from the well bore, rather than washing the cuttings into the permeable zones, reduces the potential of blocking up and in some cases sealing the permeability close to the wellbore – the effect called well-bore skin damage. A relatively small amount of interference to the flow from the formation into the well-bore, or skin damage, can have a significant effect on the productivity of the well.

Wells drilled with aerated fluids, and thus with full circulation and removal of drill cuttings show less skin damage than those drilled ‘blind’ with water. In general terms, wells with the production zone drilled with aerated fluids demonstrate better productivity than those drilled blind with water, and significantly better productivity than those drilled with bentonite mud in the production zone.

A recent drilling campaign in Kenya allows for a direct comparison between a number wells drilled as immediate offsets, to similar depths in similar locations; the original set of wells were drilled blind with water (and in one case mud) and a more recent set drilled with aerated water. The productivity of the wells drilled with aerated fluids, on average is more than double that of the wells drilled without air (Table 1).

3.3 Cuttings return

As indicated above, the primary objective of utilising aerated drilling fluids is the maintenance of drilling fluid circulation, the obvious corollary to this is the continued return of drilling cuttings back to the surface, and thus the ability to collect and analyse cuttings from the total drilled depth. While this is not always achieved for the entire drilled depth of wells drilled with aerated fluids, it is usual for circulation to be maintained for a significant proportion of the drilled depth.

3.4 Drilling materials

A significant reduction in the consumption of bentonite drilling mud and treating chemicals, cement plugging materials, and bentonite and polymer ‘sweep’ materials can result from the use aerated water or mud. In addition a major reduction in the quantities of water consumed occurs. Typically, approximately 2000 litres per minute will be ‘lost to the formation’ while drilling an 8½” hole ‘blind with water’. Aeration of the fluid allows almost complete circulation and re-use of drilling water.

3.5 A fishing tool

Perhaps the most common reason for stuck drill-string is inadequate hole cleaning – the failure to remove cuttings from the annulus between the hole and the drill string. Often, the hole wall in the region of the loss zone acts as a filter, allowing fine cutting particles to be washed into the formation while larger particles accumulate in the annulus. Under these circumstances, if a new loss zone is encountered and all of the drilling fluid flows out of the bottom of the hole, these accumulated cuttings

TABLE 1: Comparison of thermal outputs of wells drilled with and without aerated fluids at Olkaria, Kenya

Wells drilled blind with water		Wells drilled with aerated fluid	
Well No.	Output (MWt)	Well No.	Output (MWt)
1	43.31	A-1	37.05
2	12.75	A-2	98.73
4	22.15	A-4	58.86
5 (drilled with mud)	14.76	A-5	105.49
6	21.38		
		B-1	27.59
		B-3	36.26
		B-7	32.72
		B-9	67.63
Average	22.87		58.04

fall down around the bottom hole assembly and can result in stuck and lost drill strings. Aerated drilling prevents the accumulation of cuttings in the annulus and allows for circulation to be maintained even when new loss zones are encountered. In the event that a significant loss zone is encountered and the pressure balance disrupted, circulation may be lost and in severe cases the drill string may become stuck; with adjustment of the air / water ratio it is usually possible to regain circulation, clear the annulus of cuttings and continue drilling with full returns of drill water cuttings to the surface.

The air compression equipment has on numerous occasions been utilised to pressurise the annulus around a stuck drill-string, such that the water level in the annulus is significantly depressed. If the pressure in the annulus is then suddenly released the water in the annulus surges back up the hole, often washing cuttings or caved material packed around the drill string up the hole and thus freeing the stuck drill string.

3.6 Well recovery

Wells drilled 'blind with water' usually experience a significant recovery heating period after completion of the well. The large volumes of water lost to the reservoir can take a long period to heat up. Aeration of the drilling fluid limits the loss of fluids to the formation and the cooling of the reservoir around the well. The temperature recovery of wells drilled with aerated fluids is significantly faster. Typically a well drilled with water 'blind' can take from 2 weeks to 3 months for full thermal recovery. Wells drilled with aerated fluids tend to recover in periods of 2 days to 2 weeks.

4. DISADVANTAGES

Whilst the aerated drilling technique provides many benefits, it also introduces some negative aspects.

4.1 Cost

The rental of aerated drilling equipment, the additional fuel consumed plus two operators imposes an additional operational daily cost against the well. Typically this additional cost will be in the order of US\$150,000 to \$250,000 per well, or if we assume a typical geothermal cost of US\$3.5 million, the aerated drilling component of this cost will be in the order of $\pm 6.0\%$.

4.2 Non-productive time activities

Aerated drilling requires the utilisation of a number of non-return valves or 'string floats' to be placed in the drill string. Prior to any directional survey these floats must be removed from the drill string – this requirement imposes additional tripping time of approximately half an hour each time a survey is carried out. However, when comparing 'non-productive' time between aerated drilling and 'blind' drilling with water, the time lost when washing the hole to ensure cuttings are cleared when 'blind' drilling is comparable if not more than that lost retrieving float valves when aerated drilling.

4.3 Potential dangers

Drilling with aerated fluids requires the drilling crew to deal with compressed air and with pressurised high temperature returned fluids at times, neither of which are a feature of 'blind' drilling with water. These factors are potentially dangerous to the drilling crew and require additional training, awareness and alertness. The author is not aware of any notifiable 'Lost Time Injuries' that have occurred as a direct result of using aerated drilling fluids since the technique was introduced in the early 1980's.

While drilling within a geothermal reservoir system under aerated ‘balanced’ conditions, the potential for the well to ‘kick’ is significantly higher than if being drilled with large volumes of cold water being ‘lost’ to the formation’. Well ‘kicks’ are a relatively common occurrence when drilling with aerated fluids, however the use of a throttle valve in the blowline causes an increase in back-pressure when an increase in flow occurs, which tends to automatically control and subdue a ‘kick’. The author is not aware of any uncontrolled blow-outs of geothermal wells that have resulted from the use of aerated fluids.

4.4 Drill bit life

Aerated drilling prevents the loss of drilling fluid to the formation and thus reduces the cooling of the formation and near well bore formation fluids. The drill bits and bottom hole assemblies used are therefore exposed to higher temperature fluids especially when tripping in, reducing bearing and seal life, and thus the bit life. This reduced life is however, usually a time dependant factor, which, when drilling some formations is compensated by significantly increased rates of penetration. For example – the current aerated drilling operations in Iceland have seen average penetration rates of up to two times (2x) that previously achieved.

5. THE PROCESS

As stated in the Introduction above, to maintain drilling fluid circulation while drilling permeable formations, the hydraulic (hydrostatic and hydrodynamic) pressure in the hole must be ‘balanced’ with the formation pressure. Typically geothermal systems are significantly ‘under-pressured’ with respect to a hydrostatic column of water to the surface. To balance the pressure in the hole with the formation pressure, the density of the fluid in the hole must be reduced. Figure 1 depicts some typical geothermal formation pressure regimes with respect to a cold hydrostatic column of water from the surface. A static water level of 400 metres has been assumed.

The primary objective of drilling a geothermal well is to encounter permeability, and therefore productivity (or injectivity); and because in most geothermal systems permeability is not limited to just the reservoir formations but is also prevalent in overlying formations, it is therefore inevitable that communication between the ‘formation’ and the fluid in the hole will occur.

Figure 2 depicts typical pressures within a well with a range of drilling fluids with respect to a column of boiling water. The effective drilling fluid density can be varied in the approximate specific gravity range of 1.1 for un-aerated mud to 0.1 for air, by varying the ratio of air to liquid (see list to the right).

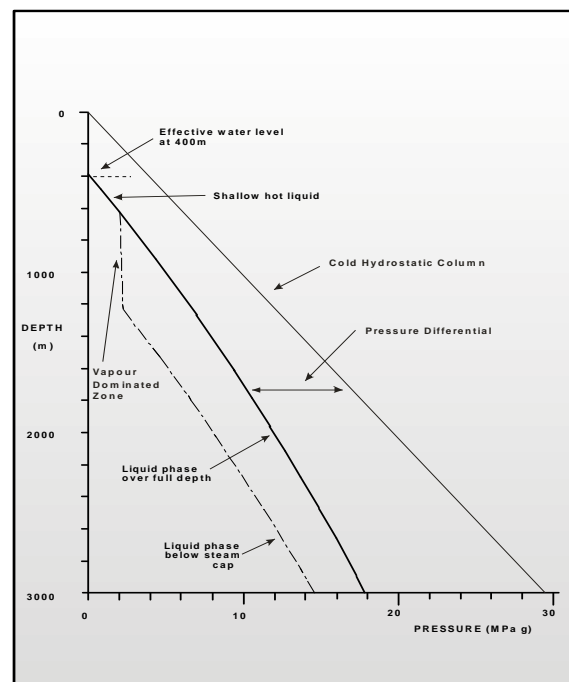

FIGURE 1: Typical formation pressures

Fluid	Effective Specific Gravity
Water based	
bentonite mud	1.1
Water	1.0
Oil Based muds	0.82
Aerated bentonite mud	0.4 – 1.1
Aerated water	0.3 – 1.0
Mist	0.05 – 0.4
Foam	0.05 0.25
Air	0.03 – 0.05

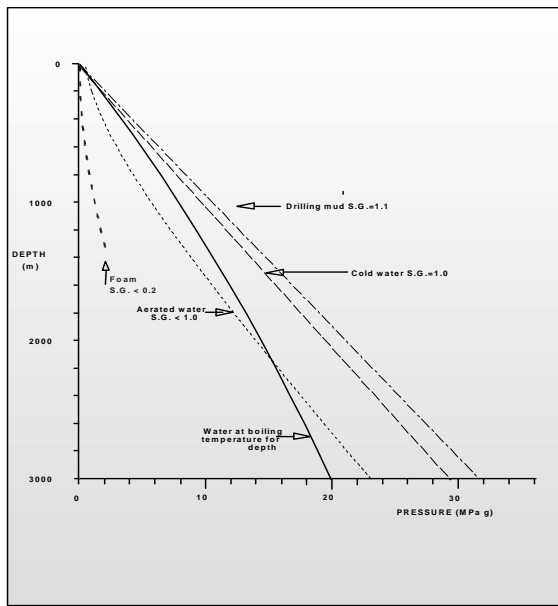

FIGURE 2: Typical downhole pressures

To ‘balance’ the downhole circulating fluid pressure with under-pressured formation conditions the density of the circulating fluid is reduced with the addition of air. The ratio of liquid to air, and the throttling of the circulating fluid outlet to produce a backpressure in the annulus are the variables which can be altered to provide the required pressure balance.

However, the addition of air into the drilling circulation system introduces a compressible component. The volume occupied by a unit mass of air at a particular depth in the hole is dependant on the fluid pressure at that depth. In other words the volume of a bubble of air at the bottom of the hole will be a small fraction of the volume occupied by the same bubble of air at the top of the hole. The density of the fluid column varies with depth and for simplicity purposes is described as a ‘liquid volume fraction’ (LVF).

LVF: 1.0 = 100% liquid
0.0 = 100% air

So not only is the pressure regime within the hole altered, but circulating fluid volume, (the LVF) and therefore the fluid velocity varies with depth of the hole.

TABLE 2: Simulation of aerated downhole conditions

Meas. Depth (m)	Vert. Depth (m)	Annular Pressure (Barg)	Diff. Press. (Barg)	Velocity (m/min)	LVF
Blooi Line	0.0	1.9	1	742.0	0.10
	100.0	4.6	3.6	219.6	0.21
	200.0	7.9	6.9	148.7	0.31
	300.0	12.0	11.0	113.9	0.40
	400.0	17.0	7.4	94.5	0.49
	500.0	22.6	4.4	82.7	0.56
	600.0	28.9	2.3	75.0	0.61
	700.0	35.6	0.9	69.7	0.66
	700.0	35.6	0.9	78.9	0.66
	800.0	42.9	-0.1	74.6	0.70
	900.0	50.4	-0.4	71.4	0.73
	900.0	50.4	-0.4	101.7	0.73
	1000.0	58.7	0.0	98.0	0.76
Bottom Hole	1000.0	58.7	0.0	98.0	0.76

Table 2 indicates an output from the GENZL Aerated Drilling Computer Simulation Package, of a typical aerated downhole annular pressure profile with downhole pressure, differential pressure (the difference between the downhole pressure and the formation pressure with a nominal static water level at 300 m depth), the flow velocity, and the Liquid volume fraction (LVF) indicated as a function of depth. The simulation is of a well with production casing set at 700 m depth, and a 100 m bottom hole drilling assembly (drill collars) – hence the parameter changes at these depths. Plots of the various parameters are indicated in Figures 3, 4, 5 and 6.

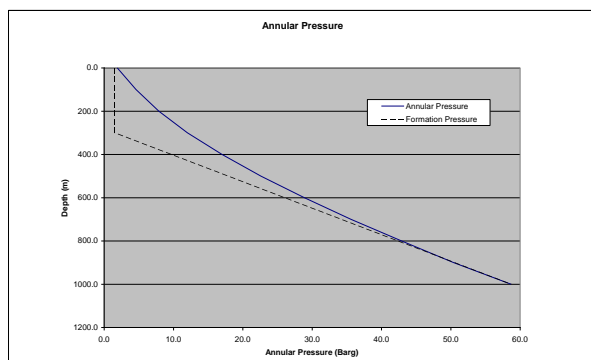

FIGURE 3: Annular pressure and formation pressure vs. depth

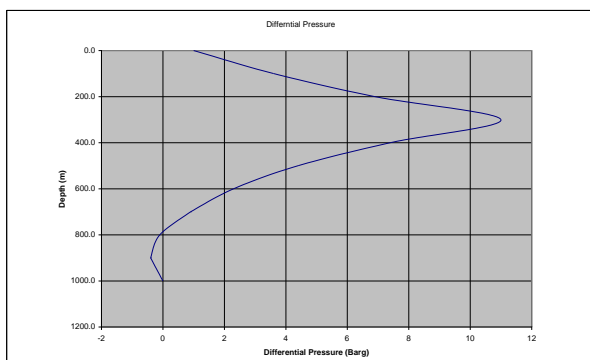

FIGURE 4: Differential pressure vs. depth

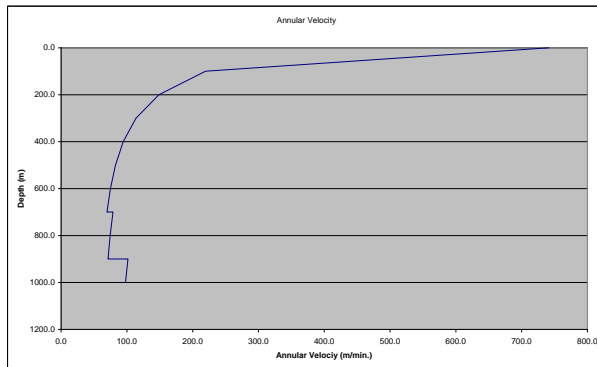

FIGURE 5: Annular velocity vs. depth

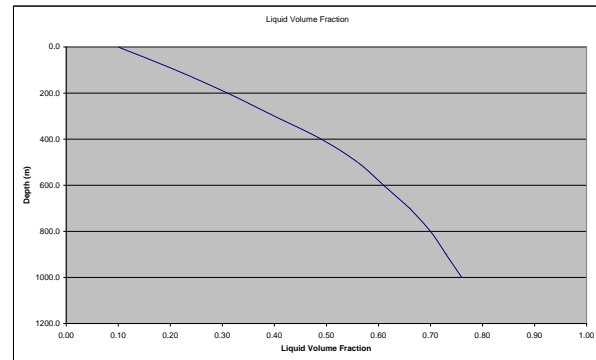

FIGURE 6: Liquid volume fraction vs. depth

Perhaps the most critical point displayed by this data is that the fluid velocities around the drill bit and bottom hole assembly are very similar to the velocities that would occur without the addition of air. The volume of liquid to be pumped must be sufficient to provide lift to cuttings over the top of the bottom hole assembly, where the diameter of the drill string reduces from the drill collar diameter to the heavy weight drill pipe or drill pipe. Typically for water drilling, a minimum velocity of 55 to 60 metres per minute is required. The volume of air to be added to this liquid flow rate will be that required to reduce the density sufficiently to provide a balance, or a differential pressure of close to zero (0) at the permeable zone or zones.

6. EQUIPMENT

6.1 General equipment

Although the equipment required to undertake aerated drilling operations varies with the type of fluid system selected, equipment common to all systems includes the following:

Primary compressors. These can be divided into two distinct types: positive displacement and dynamic. The positive displacement type is generally selected for air drilling operations and is compact and portable. The most important characteristic of this type of compressor is that any variation of pressure from the unit's optimum design exit pressure does appreciably alter the volumetric rate of flow through the machine. Pressure increases at the discharge can be balanced by an increase in input power to produce a relatively constant volumetric output, which ensures stable conditions under a variety of drilling conditions. Positive displacement units can be further subdivided into reciprocating and rotary models. Although drilling operations originally utilised the positive displacement type; technological advances have made the rotary units even more compact and less susceptible to changes in discharge pressure, which makes them more efficient when used at the high altitudes at which many geothermal fields are located. Primary compressors typically have discharge pressures up to approximately 25 bar.

Booster compressors. Boosters are positive displacement compressors that take the discharge from primary compressors and compress the air to a higher pressure (up to 200 bar). Field booster units are, in general, exit pressure (and temperature) limited. This is dependent on the inlet pressure and volumetric flowrate the booster is required to handle. As the volumetric air flowrate to the booster increases for a given booster pressure output; the booster becomes limited by its horsepower capability and similarly with an increase in output pressure. Both primary and booster compressors should have after cooling units to reduce the temperature of their discharges. The air from the primary must be cooled to reduce the power requirements of the booster and the booster discharge must be cooled

before entering the standpipe to prevent packing and equipment damage. Intercoolers are also installed between stages in multi stage units.

Fluid injection pumps. When undertaking mist or foam drilling operations, small triplex pumps are used to inject water (and foaming chemicals) into the air supply pipework at a controlled rate. These pumps generally have capacities up to 300 lpm and have coupled metering pumps for the injection of foaming agents. The compressor and booster units are usually independently diesel powered, skid mounted, and often silenced, each unit occupying a footprint of approximately 3 m x 6 m. A schematic layout of this equipment is indicated in Figure 7.

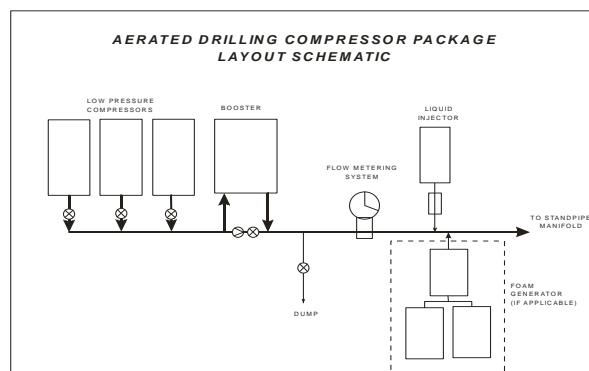

FIGURE 7: Aerated drilling air compression equipment schematic layout

6.2 Rig equipment

Standpipe manifold ducts the compressed air from the air supply line to the standpipe or away from the rig to the blooie line. Generally the manifold is located at floor level to allow operators to divert the air supply and to blow-down pressure in the standpipe to enable connections to be made. Figure 8 depicts a typical aerated drilling manifold.

Rotating head is located on the top of the B.O.P. stack and contains a packing element that rotates with the drill string and provides a seal across the annulus. The seal diverts the aerated fluid and cuttings into the blooie line. Cooling water is introduced to the rotating during drilling, prolonging the life of the packing element.

Banjo box is a heavy walled tee which is typically located in the BOP stack above the Ram gate BOP's and below the annular/spherical BOP. The branch connection of the Banjo box is fitted with an isolation gate valve with a pressure rating equivalent to the BOP stack rating (typically API #3000). A pressure spool incorporating pressure and temperature indicators and transducers is fitted immediately downstream of the isolation valve and is connected to the throttle or back pressure valve.

Blooie line is the pipework which carries the discharge to the air drilling separator, or bypasses the outflow directly to the drilling soakage pits.

Air drilling separator, a tangential entry cyclone separator, usually mounted on an elevating framework skid which provides for gravity flow of separated water and cuttings to flow from the bottom outlet to the rig shale shakers.

Figure 9 depicts a typical aerated drilling BOP stack, blooie line and separator layout schematic.

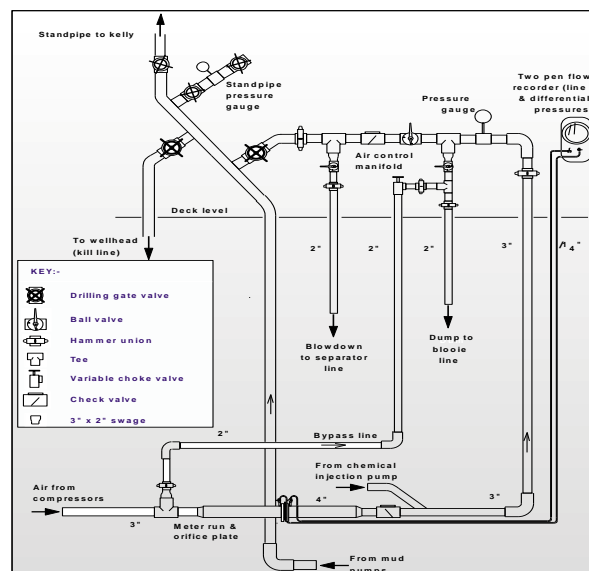

FIGURE 8: Aerated drilling standpipe manifold schematic

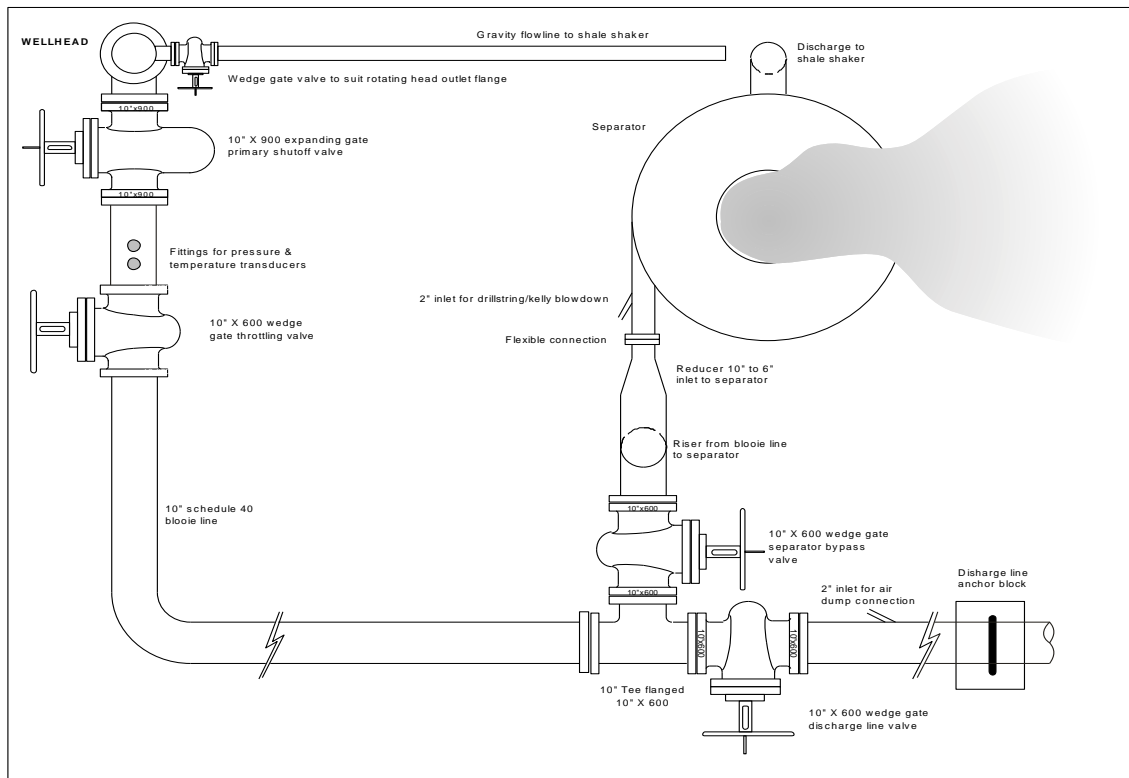

FIGURE 9: Aerated drilling wellhead, blooie line, and separator schematic

6.3 Downhole equipment

Float valves consist of small diameter poppet or flapper type valves that are inserted inside the drill pipe or collars and act as check valves for reverse air flow. One float valve, the near bit float valve is run immediately above the drill bit, preventing the plugging of the bit by halting any backflow of cuttings into the string during connections and stoppages in air supply.

A series of string float valves are run in the drill pipe as a safety precaution to prevent blow back of hot fluid and steam to the rig floor, and to decrease the connection time by keeping the aerated mixture pressurised below the top float valve. As drilling proceeds additional string float valves are added. These float valves also help reduce the time required to re-pressurise the system after a connection has been completed and keep the fluid moving around the bit while the connection is being made.

Bottom hole assemblies. In general, the drillpipe and in particular bottom hole assemblies for aerated drilling are the same as those used in standard mud or water drilling operations.

Bits. There are no special drill bit requirements for aerated drilling, however, the higher downhole temperatures experienced often reduces the life of drill bits. Particular care is required when tripping a new bit into the hole to ensure fluid is periodically circulated through the drill string to aid in cooling. Recently, PDC bits have proven very successful in particularly hot hole conditions. Without bearings or elastomeric bearing seals the PDC bit is impervious to higher downhole temperatures.

Jet subs. Aerated drilling operation carried out during the 1980's and early 1990's often utilised jet subs to aid in unloading the well. Unloading is the process of replacing un-aerated fluid in the hole with aerated fluid, achieving a return of fluids to the surface, and establishing a stable circulating regime. In resources with particularly low static water levels, this unloading process can be time consuming. A jet sub was typically located in the drill string some distance above the production

casing shoe. The relatively small volumes of compressed air bled into the annulus through the jet sub assisted in aerating the fluid in the hole close to the static water level, and providing lift to this cold cap of fluid, aiding the unloading process. In recent years with larger and more efficient compression packages the use of jet subs has diminished.

7. ENVIRONMENTAL IMPACT

There are two sources of impact that could be interpreted as different or additional to the existing impacts of a geothermal drilling operation.

Noise. The large compressor and booster units provide an additional and significant source of noise. These units are fitted with very large cooling fans which are the primary noise source. However, compressor and booster units can now be provided with full silencing to accepted noise emission standards.

Drilling fluid and cuttings returns. Aerated drilling allows for full return of drilling fluid (water) and cuttings to the surface while drilling the permeable production section of a well, in comparison, no cuttings or fluid is returned to the surface while drilling the production section of a well drilled blind with water. Aerated drilling results in a significantly larger volume of cuttings being deposited in the drilling cuttings pit.

A surfactant or foamer is usually added to the circulating water to inhibit the separation of the air from the water – the process termed ‘breakout. This foamer can cause considerable accumulation of foam in the soak pit and mud tanks. While the foam may be unsightly, it is totally biodegradable and harmless.

8. THE COSTS

The cost of any drilling operation or component of the operation is dependant upon the contract and risk regime in place. For cost analysis purposes the most definitive regime is the standard unit time rate contract structure, where the owner / operator carries full operation risk. This form of contract structure is currently the most common. Typically the cost of the aerated drilling services component will be in the order of 6% of the total cost of a geothermal well.

As an example; a deviated well recently drilled in a New Zealand Geothermal field to a depth of 2600 m, with a 9 5/8” production casing shoe set at 980 m depth, and the production section drilled with an 8½” drill bit with aerated fluids, took a period of 38 days to complete. The total well cost was US\$3,261,182.00, the aerated drilling services (including fuel) component of this cost US\$178,964.00 or 5.49%.

Table 3 details the total well cost breakdown, and Table 4 details the aerated drilling services costs. It is interesting to note that the major cost component of Aerated Drilling Services is the Equipment Standby – the aerated drilling package operated for only 13 days of the total period of 38 days drilling plus 3 days rig moving.

TABLE 3: Typical cost breakdown of a geothermal well

Well # 6 - 2600 m. 38 days			
Cost Code	Description	US\$ Totals	% of Total
1.000	Drill Site Preparation Costs	\$ 268,548.00	8.23%
2.000	Rig & Equipment Mob / Demob / Move	\$ 276,692.50	8.48%
3.000	MATERIALS		0.00%
3.100	Casings	\$ 244,910.72	7.51%
3.200	Casing Accessories	\$ 37,894.50	1.16%
3.300	Wellhead Equipment	\$ 36,686.90	1.12%
3.400	Drilling Mud Materials	\$ 32,647.80	1.00%
3.500	Drill Bits	\$ 109,598.82	3.36%
3.600	Thread Compounds	\$ 857.50	0.03%
3.700	Cementing Materials	\$ 105,406.51	3.23%
3.800	Fuel (Excluding Aerated Drilling Fuel)	\$ 146,050.45	4.48%
4.000	Drilling Services Contractor	\$ 799,811.46	24.53%
5.000	Top Drive	\$ 112,913.04	3.46%
6.000	Cementing Services	\$ 95,981.16	2.94%
7.000	Directional Drilling Services	\$ 77,365.22	2.37%
8.000	Mud Logging Services	\$ 61,544.00	1.89%
9.000	Mud Engineering Services	\$ 26,985.51	0.83%
10.000	Aerated Drilling Services (including Fuel)	\$ 178,964.61	5.49%
11.000	Rentals - Drilling Tools	\$ 54,437.02	1.67%
12.000	Miscellaneous Services	\$ 100,240.00	3.07%
13.000	Inspections, D/P Hardbanding, & Replacement, & LIH	\$ 73,160.14	2.24%
14.000	Geothermal Specialist Consultants	\$ 117,386.50	3.60%
15.000	Well Measurements	\$ 62,300.00	1.91%
16.000	Management Overheads	\$ 240,800.00	7.38%
TOTAL DRILLING COST		\$ 3,261,182.36	100.00%

TABLE 4: Aerated drilling services component cost breakdown

Aerated Drilling Cost Breakdown				
Cost Item	Description	Qty	US\$	%
10.000	Aerated Drilling Services			
10.010	Mobilisation	1.0	\$ 5,072.46	3%
10.020	Demobilisation	1.0	\$ 5,072.46	3%
10.030	Local Transport	1.0	\$ 2,800.00	2%
10.040	Equipment Standby Rate	41.0	\$ 57,483.19	32%
10.050	Equipment Operating Rate	13.0	\$ 34,949.28	20%
10.060	Operator Day Rate	33.0	\$ 25,108.70	14%
10.070	Offshore Persennel Mob Costs	1.0	\$ 2,840.58	2%
10.080	local Personnel Mob Costs	2.0	\$ 710.14	0%
10.090	PerDiem Travell Allowances	3.0	\$ 121.74	0%
10.100	Miscellaneous A/D Charges	1.0	\$ 5,072.46	3%
10.110	Stripper Rubbers	3.0	\$ 3,804.35	2%
10.120	Foamer	3.0	\$ 1,316.75	1%
3.804	Fuel for Air Package	53250.0	\$ 34,612.50	19%
TOTAL AERATED DRILLING SERVICES COST			\$ 178,964.61	100%

ACKNOWLEDGEMENTS

I thank Tuaropaki Power Company, owners and operators of the Mokai Geothermal field, New Zealand, for the use of field data and information, and for the opportunity to carry out a significant amount of aerated drilling development work while drilling Mokai wells. Thanks are also given to Mr. Lindsay Fooks, Geothermal Associates New Zealand Limited for his major efforts and inputs into developing and upgrading this component of Geothermal well drilling.

REFERENCES

Hole, H.M., 1992: *The use of aerated fluids for the drilling of geothermal well*. Lecture notes, Geothermal Institute, University of Auckland, New Zealand.

International Association of Drilling Contractors, 2003: *Underbalanced drilling operations – HSE planning guidelines*. International Association of Drilling Contractors, Houston Texas, USA.

Gabolde G., and Nguyen, J.P., 1999: *Drilling data handbook* (7th edition). Institut Francais du Pétrole Publications, Paris, 552 pp.



LECTURE 2

DIRECTIONAL DRILLING OF GEOTHERMAL WELLS

ABSTRACT

Directional drilling of geothermal wells has recently become more prevalent and popular. There are some significant advantages, including increased potential for encountering permeability and therefore production; greater flexibility in selecting well pad locations relative to the well target; and it introduces the possibility of drilling a number of wells from a single well pad. The directional drilling technology available today from the oil industry provide an array of highly sophisticated equipment, instrumentation and techniques. However, the geothermal environment is generally too aggressive to allow the use of much of it. The most successful directional wells are those with the simplest programme. Directional drilling provides an option to drill a number of wells from one pad providing significant cost savings. The wellhead layout on a multi-well pad is predominantly dictated by the dimensions of the drilling rig.

Keywords: geothermal, drilling, directional drilling, multi-well drilling pad

1. INTRODUCTION

"Directional Drilling" is the term given to drilling of a well which is deviated from the vertical to a predetermined inclination and in a specified direction. This compares with the use of the term, "deviated drilling" which usually refers to a well that is drilled off-vertical in order to sidetrack or go around an obstacle in the well. Directional wells may be drilled for the following reasons:

- Where the reservoir is covered by mountainous terrain, directional wells can access the resource from well sites located on the easier, foothill terrain.
- Where multi-well sites are constructed and a number of directional wells are drilled to access a large area of the resource from the single site.
- Where productivity is derived from vertical or near vertical fracturing, a directional well is more likely to intersect the fracture zone at the desired depth than is a vertical well.
- Where access to a critical section in another well is required – usually from which a blowout has occurred (i.e. relief well).

Where directional wells are drilled from a multi-well site, there are the following advantages:

- Total site construction costs are reduced.
- Road construction costs are reduced.
- Water supply costs are reduced.
- Waste disposal ponds for drilling effluent can serve a number of wells.
- The cost of shifting the drilling rig and the time taken are both significantly reduced.
- When the wells are completed, the steam gathering pipe work costs are reduced.

2. THE DIRECTIONAL DRILLING PROCESS

Having established the drilling target and the casing setting depths, the three dimensional geometric shape of the well needs to be determined. Typically this will be either a ‘J’ or an ‘S’ shaped well profile. The more simple ‘J’ well shape is normally comprised of an initial vertical section to the ‘kick-off’ point (KOP); followed by a curve of constant radius determined by the "rate of build" to the end of build (EOB), following by a straight section hole at a constant angle from the vertical: (final drift angle), as is depicted in Figure 1.

The ‘S’ well shape is normally comprised of an initial vertical section to the KOP; followed by a ‘build section’ with a curve of constant radius; following by a straight section hole at a constant angle from the vertical: (at the maximum drift angle); the drill bit is then allowed to fall from the start of fall point (SOF), at a constant rate of fall to the final drift angle at the end of fall point (EOF); followed by a straight of hole with the drift angle being maintained at the final angle of inclination. Figure 2 depicts a typical ‘S shaped’ well.

A planning well track profile may be formulated utilising a relatively simplistic, top-down radius of curvature calculation sheet. Typically, these calculation sheets are not target seeking – more sophisticated target seeking programs are utilised by directional drilling service companies.

Table 1 details a classic example of a simple “J” shaped well profile generated for Well MK-11 at the Mokai geothermal field, New Zealand. The 13 3/8” anchor casing is set in a vertical hole at a depth of 258 m, and a 12 1/4” hole drilled vertically to 370 m. At this depth a mud motor is run in and the well ‘kicked-off’ with a rate of build of 2° per 30 m, with an azimuth of 110°. At a depth of 580 m MD (578 m VD), the mud motor assembly is pulled from the hole and a rotary build assembly run in. Drilling of the 12 1/4” hole continues to a measured depth of 765 m (751 m VD) where the maximum and final inclination of 26° is reached. The 9 5/8” production casing is run in and set with the shoe at 760 m MD. An 8 1/2” “locked-up” rotary drilling assembly is run in and the well drilled to the final measured depth of 2400 m (2221 m VD). The resulting target point has a lateral displacement (throw) of 806 m from the wellhead, in a direction of 110° (10° south of due East), with a final measure depth of 2400 m and a final vertical depth of 2221 m. The theoretical maximum dogleg is 2° per 30 m. The vertical section and plan of this well is depicted in Figures 3 and 4.

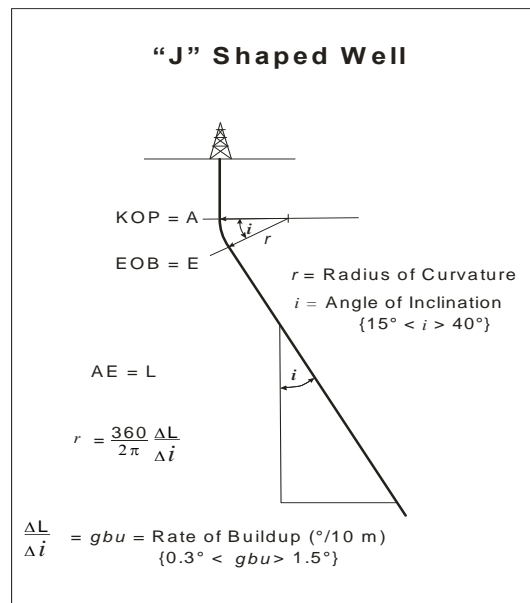

FIGURE 1: ‘J’ shape well

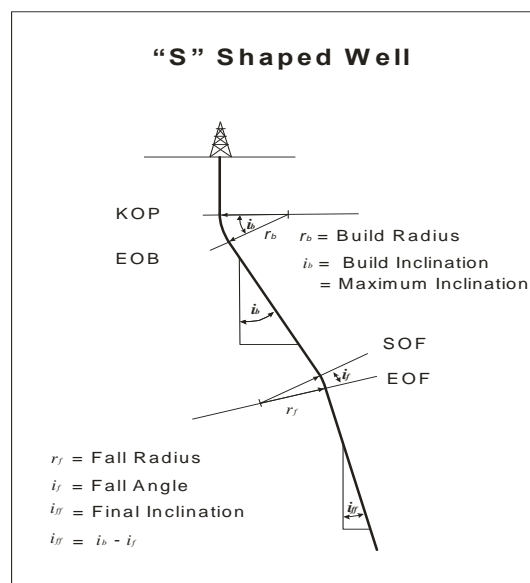

FIGURE 2: ‘S’ shaped well

TABLE 1: Mokai well MK-11 directional drilling profile

DIRECTIONAL SURVEY ANALYSIS									
Radius of curvature method E&O E 30.00									
FIELD Mokai									
WELL No. MK-11									
24-Nov-03									
Units in METERS									
Magnetic deviation -22.56 E									
Azimuth True, Grid or Magnetic GRID									
MEAS DEPTH (m)	DRIFT (")	AZIM GRID (")	VERT DEPTH (m)	COORD NORTH NZMG (m)	COORD EAST NZMG (m)	POLAR DIST (m)	POLAR BEARING (")	DOGLEG deg/30m	
0			0	6293151.07	2765363.94				
30	0.00	110.00	30	6293151.07	2765363.94	0.00	110.00	0.00	
60	0.00	110.00	60	6293151.07	2765363.94	0.00	110.00	0.00	
84.6	0.00	110.00	85	6293151.07	2765363.94	0.00	110.00	0.00	
85.5	0.00	110.00	86	6293151.07	2765363.94	0.00	110.00	0.00	
130	0.00	110.00	130	6293151.07	2765363.94	0.00	110.00	0.00	
135	0.00	110.00	135	6293151.07	2765363.94	0.00	110.00	0.00	
200	0.00	110.00	200	6293151.07	2765363.94	0.00	110.00	0.00	
250	0.00	110.00	250	6293151.07	2765363.94	0.00	110.00	0.00	
258	0.00	110.00	258	6293151.07	2765363.94	0.00	110.00	0.00	
263	0.00	110.00	263	6293151.07	2765363.94	0.00	110.00	0.00	
270	0.00	110.00	270	6293151.07	2765363.94	0.00	110.00	0.00	
280	0.00	110.00	280	6293151.07	2765363.94	0.00	110.00	0.00	
290	0.00	110.00	290	6293151.07	2765363.94	0.00	110.00	0.00	
320	0.00	110.00	320	6293151.07	2765363.94	0.00	110.00	0.00	
350	0.00	110.00	350	6293151.07	2765363.94	0.00	110.00	0.00	
370	0.00	110.00	370	6293151.07	2765363.94	0.00	110.00	0.00	
400	2.00	110.00	400	6293150.89	2765364.43	0.52	110.00	2.00	
430	4.00	110.00	430	6293150.35	2765365.91	2.09	110.00	2.00	
460	6.00	110.00	460	6293149.46	2765368.37	4.71	110.00	2.00	
490	8.00	110.00	490	6293148.21	2765371.80	8.36	110.00	2.00	
520	10.00	110.00	519	6293146.60	2765376.21	13.06	110.00	2.00	
550	12.00	110.00	549	6293144.65	2765381.59	18.78	110.00	2.00	
580	14.00	110.00	578	6293142.34	2765387.93	25.53	110.00	2.00	
610	16.00	110.00	607	6293139.68	2765395.23	33.29	110.00	2.00	
640	18.00	110.00	636	6293136.68	2765403.47	42.06	110.00	2.00	
670	20.00	110.00	664	6293133.34	2765412.65	51.83	110.00	2.00	
700	22.00	110.00	692	6293129.67	2765422.75	62.58	110.00	2.00	
730	24.00	110.00	720	6293125.66	2765433.76	74.30	110.00	2.00	
740	24.67	110.00	729	6293124.25	2765437.64	78.42	110.00	2.00	
760	26.00	110.00	747	6293121.32	2765445.68	86.98	110.00	2.00	
765	26.00	110.00	751	6293120.57	2765447.74	89.17	110.00	0.00	
790	26.00	110.00	774	6293116.82	2765458.04	100.13	110.00	0.00	
800	26.00	110.00	783	6293115.32	2765462.16	104.52	110.00	0.00	
830	26.00	110.00	810	6293110.83	2765474.51	117.87	110.00	0.00	
860	26.00	110.00	837	6293106.33	2765486.87	130.82	110.00	0.00	
890	26.00	110.00	864	6293101.83	2765499.23	143.97	110.00	0.00	
950	26.00	110.00	918	6293092.83	2765523.95	170.27	110.00	0.00	
1000	26.00	110.00	962	6293085.34	2765544.54	192.19	110.00	0.00	
1100	26.00	110.00	1052	6293070.34	2765585.74	236.03	110.00	0.00	
1200	26.00	110.00	1142	6293055.35	2765626.93	279.86	110.00	0.00	
1300	26.00	110.00	1232	6293040.36	2765668.12	323.70	110.00	0.00	
1400	26.00	110.00	1322	6293025.36	2765709.32	367.54	110.00	0.00	
1500	26.00	110.00	1412	6293010.37	2765750.51	411.37	110.00	0.00	
1600	26.00	110.00	1502	6292995.38	2765791.70	455.21	110.00	0.00	
1700	26.00	110.00	1592	6292980.39	2765832.90	499.05	110.00	0.00	
1800	26.00	110.00	1681	6292965.39	2765874.09	542.89	110.00	0.00	
1900	26.00	110.00	1771	6292950.40	2765915.28	586.72	110.00	0.00	
2000	26.00	110.00	1861	6292935.41	2765956.48	630.56	110.00	0.00	
2100	26.00	110.00	1951	6292920.41	2765997.67	674.40	110.00	0.00	
2200	26.00	110.00	2041	6292905.42	2766038.86	718.23	110.00	0.00	
2300	26.00	110.00	2131	6292890.43	2766080.06	762.07	110.00	0.00	
2400	26.00	110.00	2221	6292875.43	2766121.25	805.91	110.00	0.00	

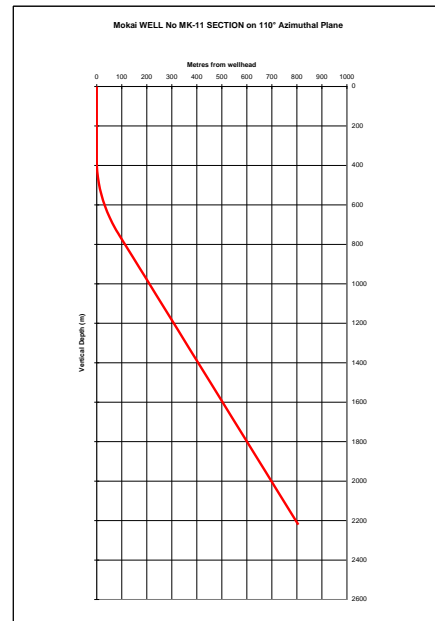

FIGURE 3: Well MK-11 vertical section

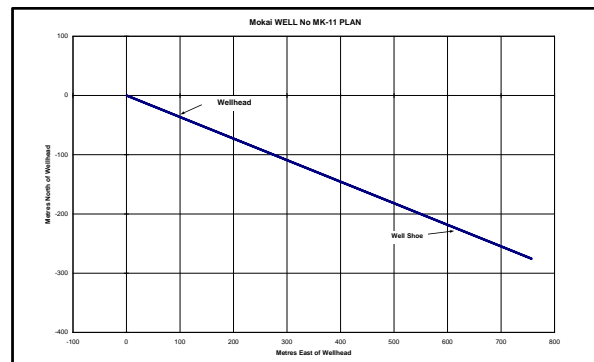

FIGURE 4: Well MK-11 plan

Table 2 details a more complex example of the “J” shaped well profile generated for Well MK-14 at the Mokai geothermal field. This well profile has a simple build in inclination, but adds a turn to the right just prior to the point where the maximum and final inclination is reached.

The 13 3/8” anchor casing is set in a vertical hole at a depth of 290 m. A 12¼” hole is then drilled vertically to 370 m, and the well kicked-off with a mud motor with a gentle rate of build in inclination of 1.5° per 30 m and with the direction held constant at 30°. At a depth of 570 m MD (568.99 m VD) the inclination is 10.0°, the tool face is adjusted and a turn to the right, at a turn rate of 3° per 30 m, is initiated. At a measured depth of 940 m MD (922.2 m VD) the final inclination of 21° is reached, and the turn to the right completed with an azimuth of 72°. The 9 5/8” production casing is set at this depth. The 8½” production hole is drilled with a fully ‘locked up’ rotary assembly to the final measured depth of 2400 m (2285 m VD). The final target point has a lateral displacement of 637.6 m from the wellhead, and a final polar bearing of 67.7°. A maximum dogleg of 3.32° occurred at 760 m MD (752.5 m VD). The vertical section and plan of this well are depicted in Figures 5 and 6.

When these two wells were drilled the actual directional profile achieved in both wells was reasonably similar to the planned profile. However, the target depth of 2400 m measured depth was not reached in either, both being terminated at a little over 2200 m measured depth due to excessive torque and drag. These results highlight the limitations the geothermal environment imposes upon directional drilling.

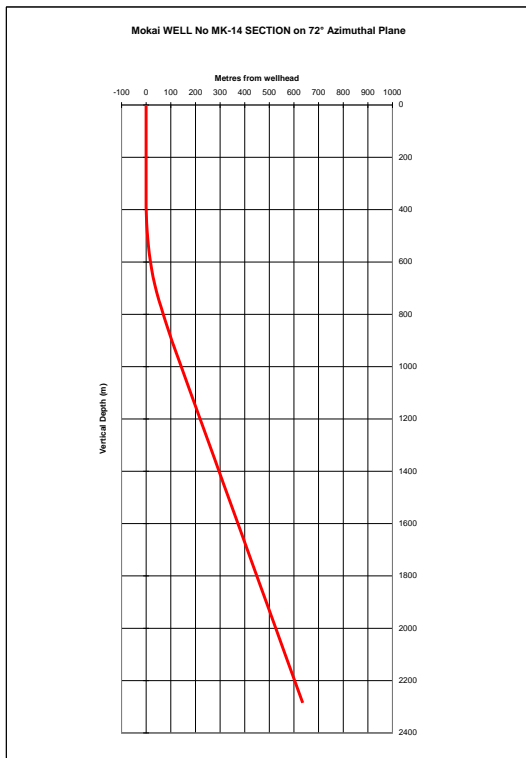

FIGURE 5: Well MK-14 vertical section

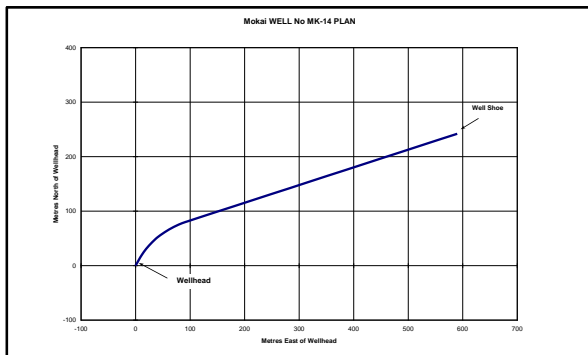

FIGURE 6: Well MK-14 plan

TABLE 2: Mokai well MK-14 directional drilling profile

DIRECTIONAL SURVEY ANALYSIS									
Radius of curvature method E&O E									
FIELD Mokai									
WELL No. MK-14									
18-Sep-06									
Units in METERS									
Magnetic deviation -22.56 E									
Azimuth True, Grid or Magnetic GRID									
MEAS DEPTH (m)	DRIFT (")	AZIM GRID (")	VERT DEPTH (m)	COORD NORTH NZMG (m)	COORD EAST NZMG (m)	POLAR DIST (m.)	POLAR BEARING (")	DOGLEG deg/30m	
0	0.00	30.00	0.00	6293162.66	2765374.39				
30	0.00	30.00	30.00	6293162.66	2765374.39	0.00	30.00	0.00	
60	0.00	30.00	60.00	6293162.66	2765374.39	0.00	30.00	0.00	
85.0	0.00	30.00	85.00	6293162.66	2765374.39	0.00	30.00	0.00	
130	0.00	30.00	130.00	6293162.66	2765374.39	0.00	30.00	0.00	
135	0.00	30.00	135.00	6293162.66	2765374.39	0.00	30.00	0.00	
200	0.00	30.00	200.00	6293162.66	2765374.39	0.00	30.00	0.00	
250	0.00	30.00	250.00	6293162.66	2765374.39	0.00	30.00	0.00	
258	0.00	30.00	258.00	6293162.66	2765374.39	0.00	30.00	0.00	
263	0.00	30.00	263.00	6293162.66	2765374.39	0.00	30.00	0.00	
270	0.00	30.00	270.00	6293162.66	2765374.39	0.00	30.00	0.00	
280	0.00	30.00	280.00	6293162.66	2765374.39	0.00	30.00	0.00	
290	0.00	30.00	290.00	6293162.66	2765374.39	0.00	30.00	0.00	
320	0.00	30.00	320.00	6293162.66	2765374.39	0.00	30.00	0.00	
350	0.00	30.00	350.00	6293162.66	2765374.39	0.00	30.00	0.00	
370	0.00	30.00	370.00	6293162.66	2765374.39	0.00	30.00	0.00	
390	1.00	30.00	390.00	6293162.81	2765374.48	0.17	30.00	1.50	
420	2.50	30.00	419.98	6293163.60	2765374.94	1.09	30.00	1.50	
450	4.00	30.00	449.94	6293165.07	2765375.79	2.79	30.00	1.50	
480	5.50	30.00	479.83	6293167.22	2765377.03	5.28	30.00	1.50	
510	7.00	30.00	509.65	6293170.05	2765378.66	8.54	30.00	1.50	
540	8.50	30.00	539.38	6293173.56	2765380.68	12.59	30.00	1.50	
570	10.00	30.00	568.99	6293177.73	2765383.09	17.41	30.00	1.50	
600	11.50	33.00	598.46	6293182.50	2765386.02	23.00	30.36	1.60	
630	13.00	36.00	627.77	6293187.75	2765389.62	29.35	31.26	1.63	
660	14.50	39.00	656.91	6293193.40	2765393.96	36.45	32.48	1.66	
690	16.00	42.00	685.86	6293199.40	2765399.09	44.28	33.90	1.69	
720	17.50	45.00	714.58	6293205.67	2765405.04	52.82	35.47	1.73	
750	19.00	48.00	743.07	6293212.14	2765411.85	62.07	37.13	1.77	
780	19.50	51.00	752.51	6293214.28	2765414.36	65.29	37.75	3.32	
790	19.17	54.00	771.39	6293218.31	2765419.61	71.71	39.09	1.57	
810	18.91	57.00	799.75	6293223.85	2765427.67	81.15	41.05	1.01	
840	18.83	60.00	828.12	6293228.94	2765435.37	90.47	42.89	0.97	
870	19.25	63.00	856.47	6293233.62	2765444.59	99.82	44.69	1.03	
900	19.83	66.00	884.75	6293237.94	2765453.64	109.31	46.47	1.16	
920	20.42	69.00	903.53	6293240.57	2765460.00	115.76	47.70	1.78	
940	21.00	72.00	922.23	6293242.93	2765466.67	122.31	48.98	1.82	
945	21.00	72.00	926.90	6293243.48	2765468.37	123.96	49.30	0.00	
970	21.00	72.00	950.24	6293246.25	2765476.89	132.27	50.80	0.00	
1000	21.00	72.00	978.25	6293249.57	2765487.12	142.34	52.37	0.00	
1100	21.00	72.00	1071.61	6293260.65	2765521.20	176.51	56.28	0.00	
1200	21.00	72.00	1164.96	6293271.72	2765555.28	211.23	58.91	0.00	
1300	21.00	72.00	1258.32	6293282.80	2765589.36	246.27	60.80	0.00	
1400	21.00	72.00	1351.68	6293293.87	2765623.45	281.51	62.22	0.00	
1500	21.00	72.00	1445.04	6293304.94	2765657.53	316.88	63.32	0.00	
1600	21.00	72.00	1538.40	6293316.02	2765691.61	352.35	64.20	0.00	
1700	21.00	72.00	1631.75	6293327.09	2765725.70	387.89	64.92	0.00	
1800	21.00	72.00	1725.11	6293338.17	2765759.78	423.47	65.51	0.00	
1900	21.00	72.00	1818.47	6293349.24	2765793.86	459.10	66.02	0.00	
2000	21.00	72.00	1911.83	6293360.32	2765827.94	494.75	66.45	0.00	
2100	21.00	72.00	2005.19	6293371.39	2765862.03	530.43	66.83	0.00	
2200	21.00	72.00	2098.55	6293382.46	2765896.11	566.13	67.15	0.00	
2300	21.00	72.00	2191.90	6293393.54	2765930.19	601.85	67.44	0.00	
2400	21.00	72.00	2285.26	6293404.61	2765964.28	637.58	67.70	0.00	

3. LIMITATIONS

Well design aspirations have to be tempered to what is realistically achievable. The directional drilling technology available from the drilling industry far exceeds what is practicably useable in most geothermal environment. Simplicity of design, and of the equipment to be utilised are key to success.

- The majority of mud motors, MWD (Measure While Drilling) tools, and downhole deviation instrumentation have operational temperature limitations of around 150°C. The KOP and initial build and directional drilling should be carried at depths where temperatures are not too high, <150°C.
- The kick-off and the initial build and directional drilling is more efficient and more successful if carried out in a ‘smaller’ diameter hole – but the smallest diameter hole sections are deep and therefore hotter. Typically the KOP should be just below the anchor casing shoe (either 17½” or 12¼” hole section).

- Rate of build and rate of turn must be as low as possible, 1.5° - 3° per 30 m.
- A final drift angle in excess of 15° is desirable. Drift angles less than this may create difficulties in maintaining a constant direction (azimuth). Depending on the formations being drilled, a final drift angle of 25° - 35° would be common.

These limitations generally require that a significant proportion of the directional drilling must be carried out with rotary bottom hole assemblies, and that directional measurements must be made using ‘slickline’ instruments – retrievable tools equipped with thermal protection, run and retrieved in the drillpipe on non-electrical wireline. Rotary bottom hole assemblies and variation of the ‘weight on the bit’ (WOB) and the rotary speed (RPM), can be formatted to provide build, maintain a straight hole, or allow the inclination to fall. Rotary bottom hole assemblies provide little control over the hole direction (azimuth control).

Mud motors and MWD (Measure While Drilling) instrumentation can be utilised in the upper, lower temperature hole for the kick-off, to establish a smooth and regular build in inclination – usually to a round 10° to 20°; and to establish the desired direction (azimuth). Beyond these depths it is advisable to utilise rotary bottom hole assemblies to continue the build, hold the current angle, or allow the inclination to fall. Typical rotary assemblies to achieve these directional requirements are shown in Figures 7, 8, and 9.

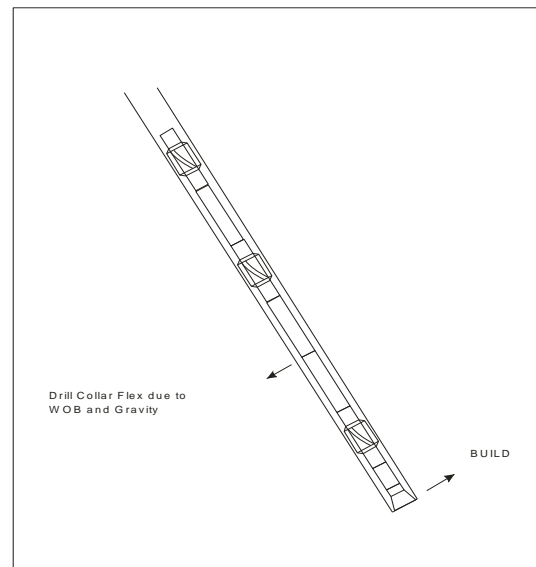

FIGURE 7: Typical rotary build assembly

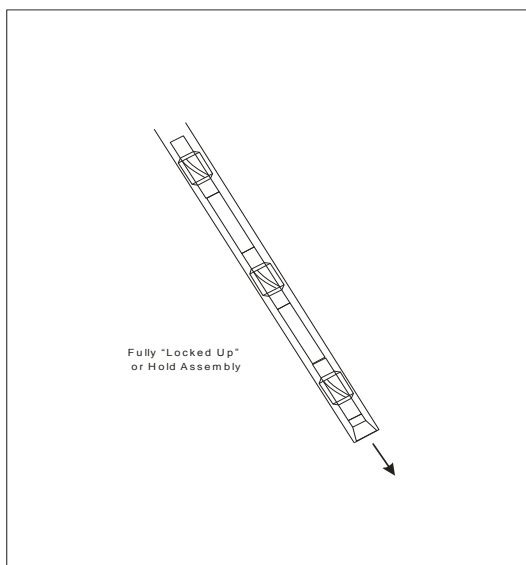

FIGURE 8: Typical rotary “hold” assembly

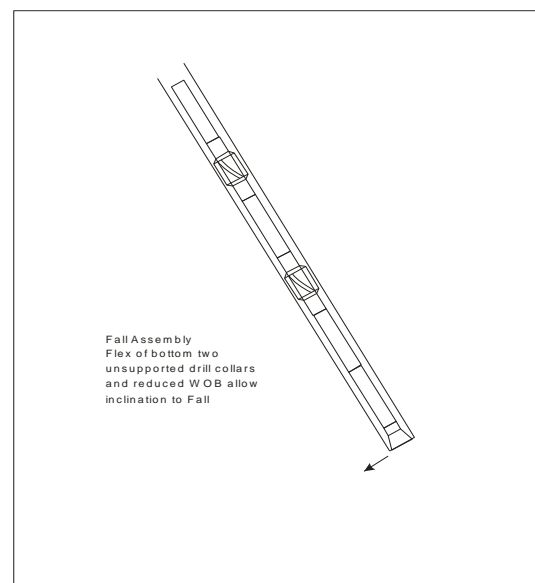

FIGURE 9: Typical rotary fall assembly

4. PROXIMITY OF OTHER WELLS

Where other vertical or directional wells are in the vicinity of a planned well, the new well track proximity to open hole section of other wells must be considered. In the extreme, if the new well track being drilled passes close to an existing productive well, such that communication between the new

well and the open hole section of the existing well is the possible, the potential for a blowout in the new well exists. Of less extreme concern is possibility of production interference between wells. If the spacing between two wells drawing from the same permeable horizon is insufficient, localised drawdown can affect the productivity of both wells. To avoid these possibilities it is desirable that the separation between the production casing shoes and the open production holes is maximised. Typically, close approach of the production sections of any two wells should not be less than 200 m.

5. MULTI- WELL PADS

The ability to successfully drill directional geothermal wells has progressed to the obvious conclusion of drilling more than one well from the same drilling location. The economic savings accrue from:

- Reduced drilling pad civil construction costs – one slightly drilling pad with a slightly increased area can accommodate a number of wells. Only one access road requires construction, only one drilling effluent soak pit requires construction.
- Reduced rig moving costs – typically, the cost of moving a drilling rig from one location to another is in the order of US\$500,000, taking a period of around two weeks; while a rig ‘skid’ from one well to the next on the same pad is generally carried out at the rig operating rate and can usually be achieved in a period of two days, at a cost in the order US\$120,000.
- Reduced water supply system installation costs.
- Significantly reduced steam gathering pipework costs.

The disadvantages can be accommodated or easily mitigated:

- Live wellheads close to a drilling operation – an element of danger exists in that having completed a successful geothermal well, the rig is skidded only a distance of 5 to 10 metres from the now ‘live’ wellhead. There is a potential for damaging the live wellhead. This concern can be mitigated with the placement of a temporary protective cover over the ‘live’ wellhead.
- Drilling cutting soakage pits need to accommodate much greater quantities of cuttings and therefore need to be larger, and should be designed such that they can be emptied or at least partially emptied while in operation.

The well pad layout is generally dictated by the drilling rig being utilised to drill the wells, and by a rule of thumb minimum spacing of a least 5 m. such that the chance of collision in the initial vertical sections of the wells is minimised. Wellhead spacing must be such that when a well is completed, the rig can be ‘skidded’ or ‘walked’ off the well to the next wellhead, leaving the completed well accessible for completion tests, and even vertical discharge testing without significant interruption of drilling activities on the new well.

After completion of drilling of all of the wells on the well pad, there is always the possibility that workover activities may be required on any of the wells. The steam gathering pipework must be designed in a manner that access to each wellhead is available without disconnection of adjacent wells.

6. AN EXAMPLE OF A MULTI-WELL PAD – MOKAI, NEW ZEALAND.

During the period October 2003 to June 2004 six (6) wells were drilled at the Mokai geothermal field. Wells MK-10 through MK-15 were drilled from a single wellpad designated MK-II, with Parker Drilling International Rig 188, a 2,700 HP, 1.2 million lb, walking box base rig. All six well were drilled directionally, with 9 5/8” production casing and 8½” diameter production hole sections. Figure 10 is a map of the Mokai area with the well-tracks of the six production well-tracks overlaid. The cased sections are indicated in grey, while the open productions are in white.

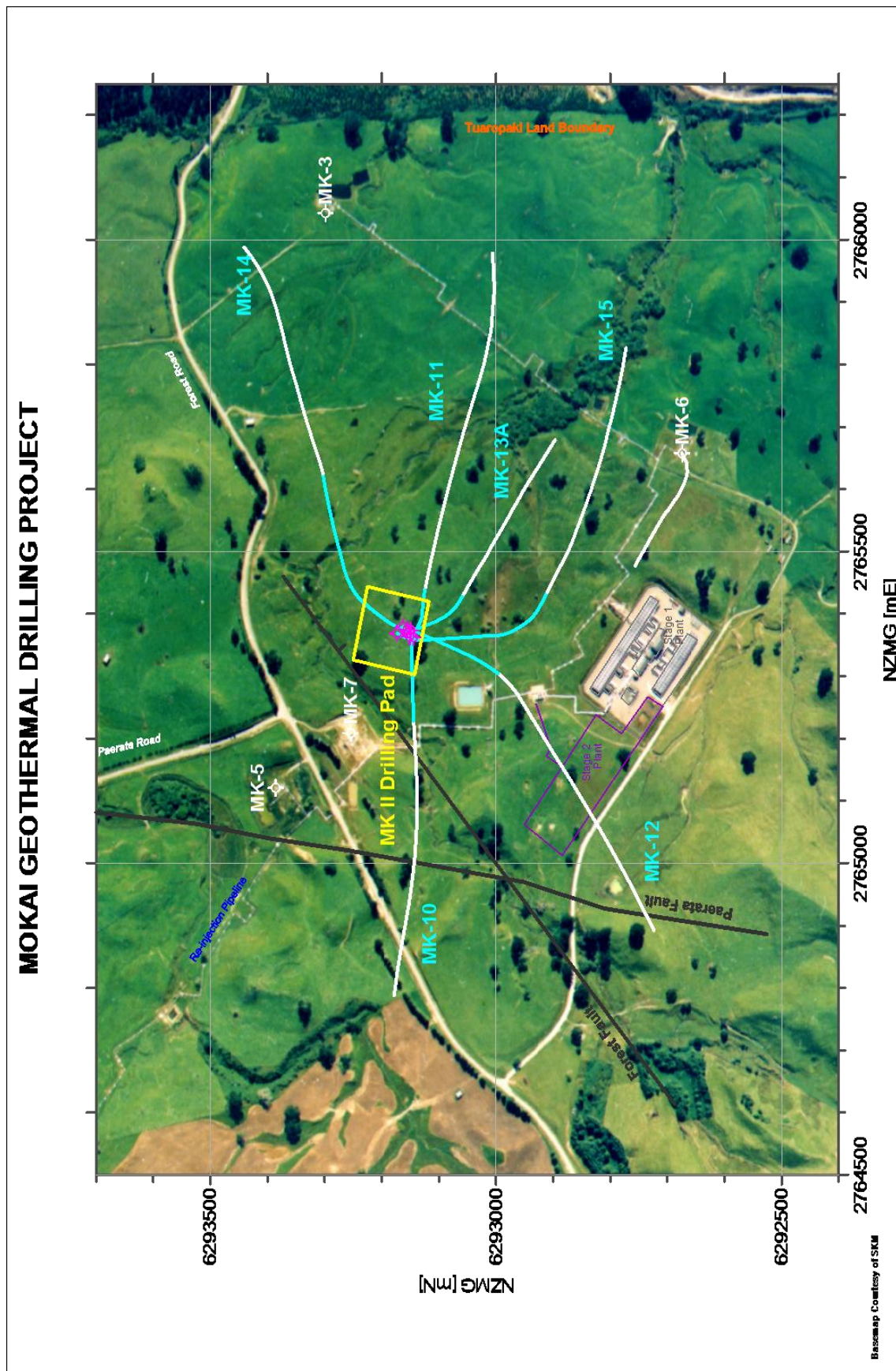

FIGURE 10: Mokai well pad MK-II with wells MK-10, MK-11, MK-12, MK-13, MK-14 and MK-15 as drilled well tracks (cased sections indicated in grey/green; production sections indicated in white)

The layout of the wellheads was dictated by the dimensions of the drilling rig sub-base, which was a hydraulically powered walking box base, allowing the rig to be easily walked backwards and forwards, and sideways in each direction. The box sub-base overall dimensions were 22 m long by 9 m wide, with 'hole centre' 10 m from the front toe and centred on the lateral dimension. These box base dimensions required that adjacent wells have at least a 6.0 m lateral spacing, and a 10 m longitudinal spacing, relative to the rig sub-base. Figure 11 is a plot of the wellhead locations on the MK-II drilling pad.

7. DRILLING CELLAR OPTIONS

One option which simplifies multi-well pad is to construct a single 'trough' type drilling cellar, approximately 2 m deep with the wells spread in a single line along the trough. {Wayang Windu, Indonesia; Olkaria West, Kenya}. The wellhead and master valve being mounted such that the top of the master is just below ground level. This type of configuration allows a simple cover to be placed over the wellhead, eliminating interference to on-going drilling operations. However, the concept of a relatively large and deep cellar has been 'de-popularised' by health and safety concerns relating to the possible accumulation of toxic gases.

More typically, single cellars are constructed for each well, and the master-valve is mounted above ground level-requiring protective covers to put in place while on-going drilling operations continue.

ACKNOWLEDGEMENTS

I thank Tuaropaki Power Company, owners and operators of the Mokai geothermal field, New Zealand, for the use of field data and information.

REFERENCES

Hole, H.M., 1996: Seminar on geothermal drilling engineering. *Geothermal Energy New Zealand Ltd., Jakarta, Indonesia 4-8 March 1996*, Seminar Handbook, Section III, 50-55.

Gabolde G., and Nguyen, J.P., 1999: *Drilling data handbook* (7th edition). Institut Francais du Pétrole Publications, Paris, 552 pp.

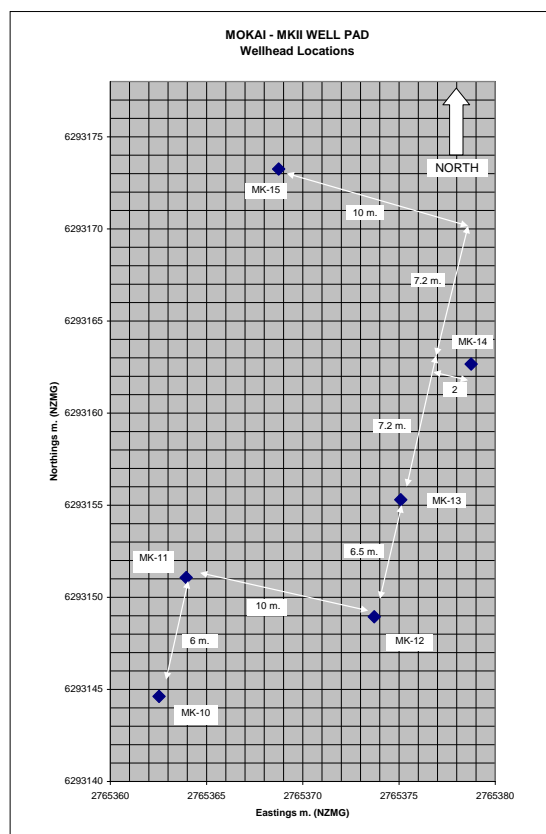

FIGURE 11: Wellhead locations on Mokai well pad MK-II



LECTURE 3

GEOHERMAL WELL DRILLING SERVICES CONTRACTS

ABSTRACT

The somewhat unique geothermal drilling services contract environment that functions in Iceland has prompted the preparation of this brief paper, outlining the range of possible contract environments, and some of the associated benefits and drawbacks.

Keywords: geothermal, drilling, drilling services contract

1. INTRODUCTION

Iceland's current geothermal drilling operations are being executed under drilling service contract structures which are predominantly metre-rate and 'turnkey' in nature. This is in contrast to the contract environments currently adopted in recent New Zealand, Kenyan and Indonesian geothermal drilling operations which are predominantly 'unit time rate' contracts.

2. COMPONENTS OF A GEOHERMAL DRILLING OPERATION

Any geothermal drilling operation includes a wide range of activities and processes all of which must be provided and executed. These activities and processes will include, but not necessarily be limited to:

- Reservoir engineering and well targeting.
- Well design and specification.
- Drilling materials specification and procurement.
- Well pad, access road civil design and engineering.
- Water supply design and engineering.
- Well drilling engineering and supervision.
- Provision of drilling rig and equipment.
- Provision of drilling personnel.
- Provision of top drive unit and personnel.
- Provision of cementing equipment, personnel and services.
- Provision of directional drilling equipment and personnel.
- Provision of mud engineering personnel.
- Provision of aerated drilling equipment and personnel.
- Provision of mud logging / geology equipment and personnel.
- Drilling tool rental.
- Drillpipe inspection.
- Drillpipe hard-banding.
- Provision of well measurements equipment and personnel.

These activities and processes may be provided to an Owner under a large number of totally separate and discrete service contracts, or conversely under one lead contract, or any mix between these two extremes. An Owner who desires to drill a geothermal well will have to decide on what contractual basis each and every one of these activities and process is to be provided. The level of control, responsibility and risk that the Owner wishes to take, will determine the mix between having many separate contracts or just one lead contract.

3. GEOTHERMAL OWNER RISKS

Owner risk could be defined as the ‘potential cost to the Owner if the actual outcome of an operation does not match the planned and expected outcome’. An Owner carrying out a geothermal drilling operation is faced with a number of risk components. Unlike a building or civil construction project, a drilling operation involves a significant ‘unknown’ factor. A building or civil construction project is generally carried out on the basis of a ‘blue-print’ – a detailed plan of exactly how the construction process will occur and be completed. While the ‘blue-print’ can never totally eliminate all unknowns, the majority of the activities relate to ‘visible’ and tangible situations. In comparison a drilling operation is based on a ‘nominal’ programme, which is based on ‘best estimates’ only, and deals with ‘invisible’ and ‘interpreted’ situations.

4. RESPONSIBILITY, CONTROL AND RISK

The ‘scope of work’ of a drilling services contract will define clearly the split of responsibility between the Owner and the Contractor. For example, the contract may define that the Contractor is responsible for maintaining sufficient fuel on the rig site to ensure no interruption in the drilling activities. The contract may define that the cost of the fuel is carried directly by the Owner, or by the Contractor who shall be reimbursed with an appropriate mark-up. The responsibilities, as defined, place control of ordering and procurement of fuel with the Contractor. The Contractor carries the operational risk that in the event that he fails to maintain sufficient fuel on site and drilling operations are effected then he will be penalised accordingly – most probably he will not be paid for the period of lost time. The Contractor will factor into his fee structure an amount to cover the possibility that he will be penalised at some stage.

Operational responsibility, control and risk are all interlinked. Operational responsibility implies operational control, but imposes operational risk, as depicted in Figure 1.

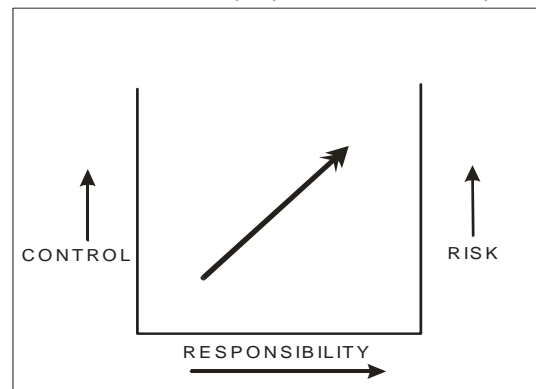

FIGURE 1: Responsibility, control and risk matrix

An Owner who may decide to take technical and managerial responsibility, receives operational control but must accept the consequential risk. This situation is implied when an Owner selects to enlist all, or a significant proportion, of the activities and process under separate and discrete contracts.

Typically an Owner entity, such as Orkaveita Reykjavíkur – Reykjavík Energy, may have within its own resources a geoscientific and engineering capability (or separately contracted these capabilities through a consultant). The reservoir engineering and well targeting; the well design, materials specification and procurement; the drilling pad and access road civil design and construction supervision; and finally the drilling engineering and drilling supervision, will all be provided by the Owner through his ‘in-house’ or consultant capabilities.

The drilling services contract in this scenario would typically be a simple unit day rate contract – the Owner is simply renting the drilling equipment and personnel required to operate it. The Owner is fully responsible for instructing the Contractor through each and every step of the operation, and has total control on how each step will be performed. The Owner carries all the operational responsibility, and of course all the operational risk. If there are some downhole problems and delays to progress, the Owner continues to pay the daily fee rate.

In contrast to this model, the Owner may decide that the operational responsibility and control should lie totally with the Contractor, a contractual model generally termed ‘Turnkey’. In essence the scope of work given to the Contractor could be – “drill me a geothermal well in this particular place into this particular reservoir – come back and tell me when it is finished”. The Owner may have no ‘in-house’ technical capability, and may not have the required managerial resources. The Contractor in this case, is totally responsible, has full control of how and when activities occur, and carries all of the operational risk. The price the Contractor will charge the Owner will include an amount to cover the equipment rental and personnel, a management component, and an operational risk component – these management and risk components can be significant.

5. THE COST OF OPERATIONAL RISK

In comparing these two extreme contract models the costs of the equipment rental and personnel components should be the same. The cost of the management component should be similar, either the Owner pays for his own resources or he contracts them in either through a consultant hired directly by the Owner, or through the Contractor. It is the cost of the operational risk component that will be significantly different.

In the case where the Owner takes full responsibility, he will incur costs associated with risk only in the event that a problem occurs. The Owner will pay for additional rig time only in the event that there is a problem causing a delay.

In the Turnkey contractual model, the Contractor will have to assess the likelihood of problems occurring, and will build into his price a component to cover such an occurrence. Of course his objective will be that he will ‘manage’ the operation successfully and avoid problems, turning the operational risk component of the price into a pure profit component. The difference to the Owner is that he will pay the operational risk component whether a problem occurs or not.

6. DOWNHOLE RISK

A significant sub-set of geothermal drilling operational risk is the downhole risk – the risk of losing drilling equipment down the hole, and the risk of losing the hole itself in part or in full. Typically, drilling contracts pass the downhole risk, in full, to the Owner. That is, any damage to or loss of equipment that occurs below ground level, and any damage to or loss of the hole itself is generally always to the full account of the Owner. The only exception will be when proven negligence by the Contractor can be shown to be the cause of the loss.

In Turnkey type contracts there is often a proportional responsibility, where even though the Contractor has full responsibility and control of the operation, some proportion of the cost of covering the downhole loss or damage will be borne by the Owner.

7. RESOURCE RISK

Perhaps the most significant Owner risk is the production (or reinjection) success of the completed well, generally termed the resource risk. This form of risk is obviously extreme in the case of exploration and green-field wells, and will be inversely proportional to quantity and quality of the geoscientific survey work carried out. The resource risk diminishes as understanding of the reservoir structure and the nature of the resource and formation increases. With each well drilled and completed comes a better understanding of the formations and the resource, resulting in the lowering the resource risk.

It is extremely uncommon that an Owner can pass the resource risk to others through a contract structure. One example where this can occur, is a steam production based drilling contract – where the Contractor is paid for drilling a well on the basis of the mass flow or the Megawatts of electricity produced from the completed well. This type of contract was used for a short period in New Zealand, but as far as the author is aware, with unsatisfactory results.

8. CONSEQUENTIAL RISK

In the event that some significant drilling delay occurs or the productivity of a well or wells is not as expected, delays to commencement of planned generating may occur. The lost revenue, and possibly penalties for non-supply may be a result, and would fall into the category of a consequential loss. This type of loss is typically covered by insurance, but unless negligence can be proven, must be to the account of the Owner.

9. FINANCIAL RISK

The Owner of a geothermal drilling operation will usually be constrained to a financial budget of some form while executing the operation. If an Owner desires full technical control of a drilling operation and accepts the associated responsibilities and risks, this normally leads to some form of unit time rate contract, which will impose a financial risk with respect to the budget. By definition a unit time rate contract is unlikely to be completed ‘on-budget’, there is a chance that the well be completed ‘under-budget’, and there is a financial risk that the cost of completing the well will exceed the budget.

The only way an Owner can minimise the financial risk is by converting all or part of the drilling operation to a fixed or ‘lump sum’ contract. Any ‘conversion’ to a fixed fee, shifts responsibility and therefore control back to the Contractor and away from the Owner.

10. AN OWNER’S CHOICE

The Owner of a geothermal drilling operation is faced with balancing the level of technical and managerial control of the drilling operation he desires, against the level of operational and financial risk he is willing to accept.

11. OBSERVATIONS

The trend observed recently in operations in New Zealand, Kenya and Indonesia, has been toward unit time rate contracting with owners demanding full technical and managerial control, with a willingness to accept the operational and financial risks. The upswing in demand from the oil industry over the past five years has created a shortage of available drilling rigs and suitably qualified personnel, which has in turn hardened the market and reduced the willingness of drilling Contractors to accept risk unless significantly higher levels of compensation are offered.

As stated in the Introduction, this situation is in clear contrast to the current practice in Iceland, where it is evident that a unit metre rate contract structure that places significant operational risk with the Contractor is practiced and accepted by both Owners and Contractors. The drilling Contractors that are, or were, operating in New Zealand, Kenya and Indonesia are without exception Contractors that operate predominantly in the Oil industry, with only relatively small involvement in the geothermal industry. It is evident that the reverse is the case for the Iceland based drilling Contractors.

REFERENCES

Hole, H.M., 2001: *Geothermal drilling*. Geothermal Institute, University of Auckland, Auckland, New Zealand, paper 665.620.



LECTURE 4

GEOHERMAL GREENHOUSE HEATING AT OSERIAN FARM, LAKE NAIVASHA, KENYA

Bruce Knight¹, Hagen M. Hole² and Tracy D. Mills³

¹ Oserian Development Company, P.O. Box 209, Naivasha, Kenya
(bruce.knight@oserial.com / www.oserial.com)

² Geothermal Consultants New Zealand Ltd, P O Box 34391, Birkenhead, Auckland, New Zealand
(gcnzl@ihug.co.nz)

³ Sinclair Knight Mertz Ltd, P.O. Box 9806, Newmarket, Auckland, New Zealand
(tmills@skm.co.nz)

ABSTRACT

A low output exploration well located on Oserian farm in the Olkaria geothermal field has been used to supply geothermal heat to a greenhouse complex. Heating controls night-time humidity levels in the greenhouses, thereby alleviating fungal disease and enhancing flower growth. The non-condensable gases (predominantly CO₂) produced from the well are used to enrich the atmosphere in the greenhouses, further enhancing flower growth. Fresh water is the heat storage and transport medium, which is stored in a hot water storage tank and circulated through the greenhouse heating loop when heating is required. The geothermal heating equipment is located on the well site, while the hot water storage tank is remote from the well site and near to the greenhouses. This paper discusses the geothermal-side heating system, the characteristics of the well (notably its cycling flow) and the main features of the design and construction of the heating process and control system.

Keywords: Geothermal, heating, greenhouse, Olkaria, Oserian, Kenya, East Africa

1. INTRODUCTION

Oserian Development Company owns and operates a large flower farm at Lake Naivasha, Kenya. The farm overlies part of the Olkaria geothermal area, and several exploration wells have been drilled there over the years. As is usually the case with exploration wells, they are few in number, with significant distance between each well, and can have a range of drilling outcomes.

Well OW-101 was an early exploration well drilled in 1983; it is fairly isolated from the power plant production areas, and has a very low power generation potential. Additionally, tests of the well show it has very significant flow cycling which poses difficulties for power generation. For these reasons it would be impractical to connect the well to any of the existing or planned power plants within the Olkaria geothermal area. Oserian initially made use of a small portion of well OW-101's production capacity for greenhouse heating, and has subsequently expanded the use of the well in a larger heating project. New greenhouses were constructed for the purpose.

The primary aim of Oserian's greenhouse heating is to control night-time (and wet season) humidity levels in the greenhouses, thereby alleviating fungal disease. The project provides some tangible benefit from the earlier exploration drilling efforts, and has the added benefit of allowing Oserian to provide greenhouse heating without having to burn fossil fuels. The greenhouse heating system comprises the following sub-systems:

- A geothermal heating circuit located at the well site;
- A secondary fresh water heating circuit to transport heat from the well site to the greenhouse area;
- A large heat storage tank adjacent to the greenhouses; and
- A distribution network to supply heat to the individual greenhouses as required.

The purpose of this paper is to discuss the technical aspects of the geothermal heating sub-system, including the characteristics of the well (notably its cycling flow), and the main design and construction features of the heating process and its control system. This is a re-presentation, of a paper presented at the 2nd KenGen Geothermal Conference, April 7 – 9, 2003. Some minor updates have been made.

2. WELL CHARACTERISTICS

Oserian carried out a series output test measurements of well OW-101, over a range of conditions. These tests indicated that the well has a typical average output of about 8 or 9 MW_{th} (which corresponds to less than 1 MW_e), while instantaneous values vary from about 6 MW_{th} to 15 MW_{th}. Under constant throttle conditions, the well shows dramatic swings in all flow parameters (mass flow, wellhead pressure, and enthalpy). The flow conditions cycle over a period ranging from about three hours to almost five hours. This cycling is caused by the well having two feed zones; at times one or other zone predominates yielding the observed cycling. Table 1 summarises the extent of flow cycling at several throttle settings. Figure 1 shows the well's behaviour for discharge through a 5" lip pipe with an average wellhead pressure of 3.87 bars (absolute).

There is a relatively narrow band of wellhead pressure (with average values of about 5 to 7 bars abs.) where the well has less extreme changes in output. At lower wellhead pressures (larger well openings) the flow has more severe cycling, such as shown in Figure 1, while at higher wellhead pressures the well can cease flowing.

It was decided that two-phase fluid would be used in the heating system, thereby avoiding the cost of a steam separator, and also allowing the heat in the brine to be used without the need for a separate brine heat exchanger. In addition, the choice of utilising a two phase system provided a significant construction time advantage.

TABLE 1: Extent of flow cycling

WHP (bara)			Mass Flow (kg/s)			Enthalpy (kJ/kg)		
Min	Mean	Max	Min	Mean	Max	Min	Mean	Max
3.4	4.8	7.7	7.77	10.55	16.80	1089	1238	1523
3.8	5.2	7.8	8.52	10.84	16.67	1091	1226	1464
4.1	6.0	9.5	7.17	10.00	15.99	1141	1222	1417
4.2	6.1	9.6	6.66	9.31	15.08	1221	1292	1463
4.7	7.1	11.2	6.42	8.89	14.65	1252	1384	1558

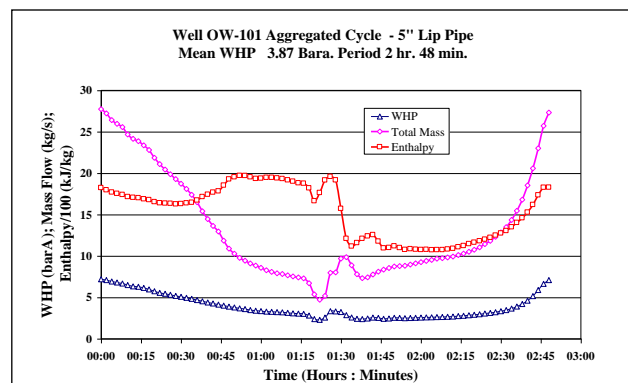

FIGURE 1: Extent of flow cycling

Careful consideration was given to the possibility of silica scaling. The well fluid has relatively high pH which tends to lower the potential for scaling. It was also considered that the residence time of the geothermal fluid within the heating system would be very short, giving a further safety margin due to the kinetics of silica scaling. Based upon available silica chemistry data, and without considering kinetics, conductive cooling of the two-phase fluid is deemed to be safe to 90 °C.

As was expected, the well fluid contains a small proportion of non-condensable gas. This is predominantly CO₂, with minor amounts of other gases including H₂S. The design of the heating system included piping and an air blower that enabled the non-condensable gases to be diluted with air, then transported to the greenhouses to enrich the air in the greenhouses with CO₂. A significant improvement in plant growth due to elevated CO₂ levels, as well as a reduction in disease due to traces of H₂S have resulted. It should be noted that gas levels are monitored and controlled in relation to plant growth and, importantly, to ensure the safety of personnel.

The design of the geothermal heating sub-system took full account of the unusual well behaviour.

3. HEATING SYSTEM DESIGN FEATURES

The design concept for the geothermal heating sub-system is depicted in the P&ID drawings in Figures 2, 3, and 4. The following sub-sections describe features of key elements of the design concept.

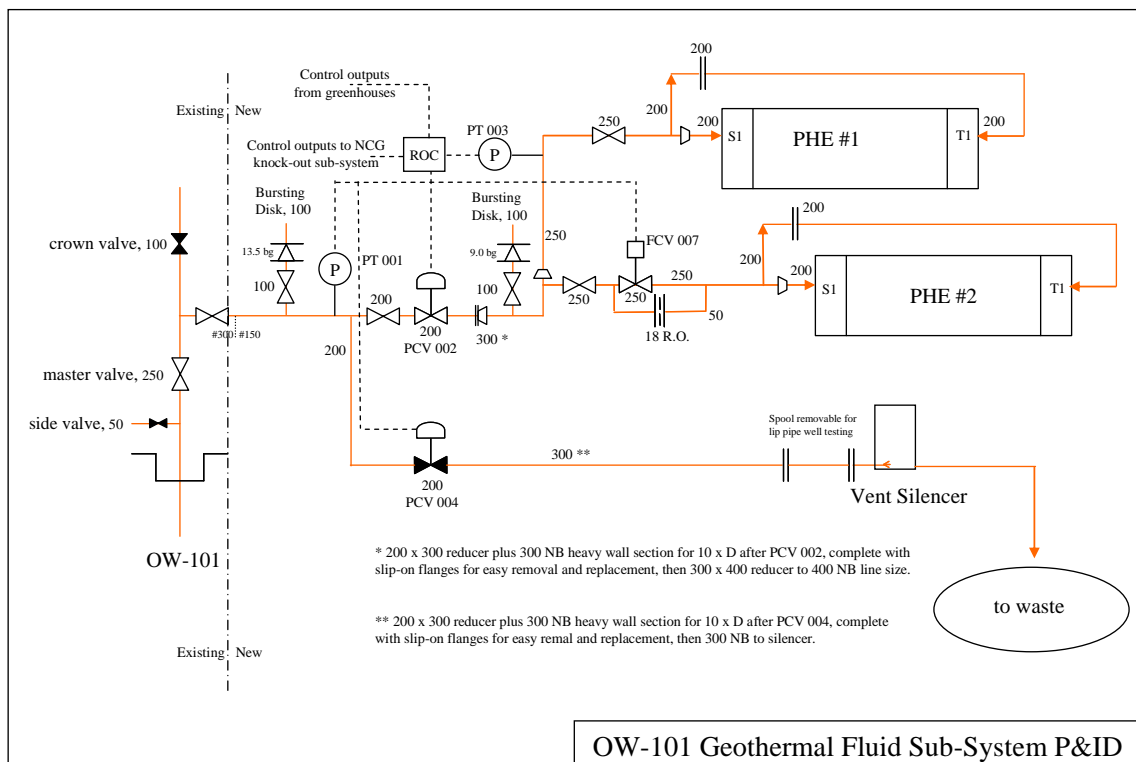

FIGURE 1: P&ID for geothermal fluid sub-system

3.1 Regulation of Process Pressure

It is desirable to maintain steady conditions in the heating system; in particular, while flow rates fluctuate, the process pressure and hence temperature is to be maintained. A high-performance ball valve is used to regulate the downstream pressure.

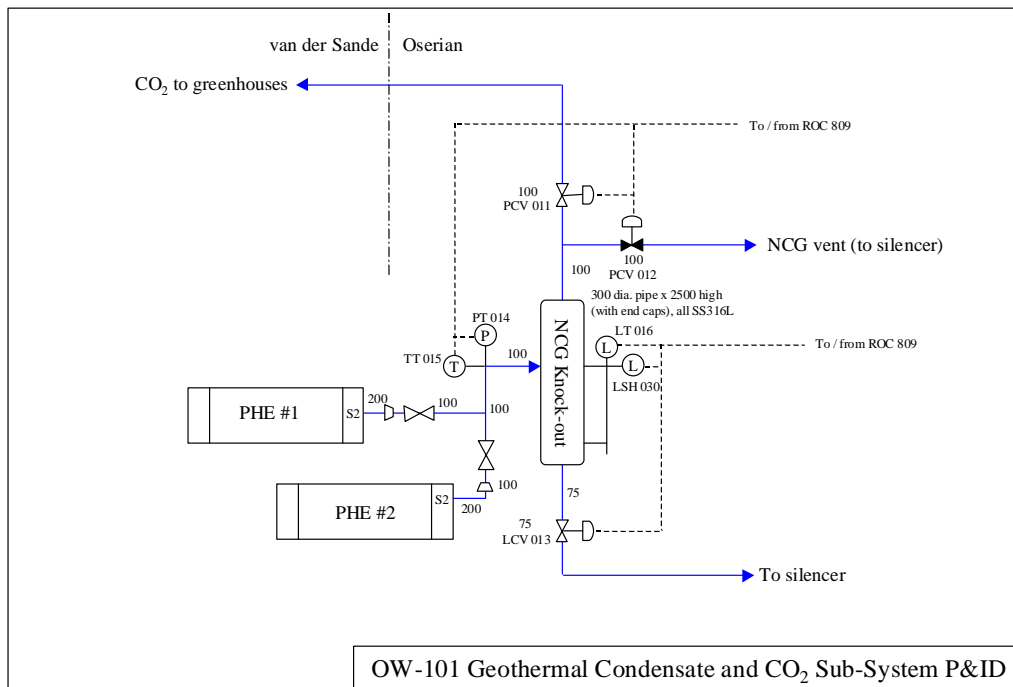

FIGURE 3: P&ID for geothermal condensate and CO₂ sub-system

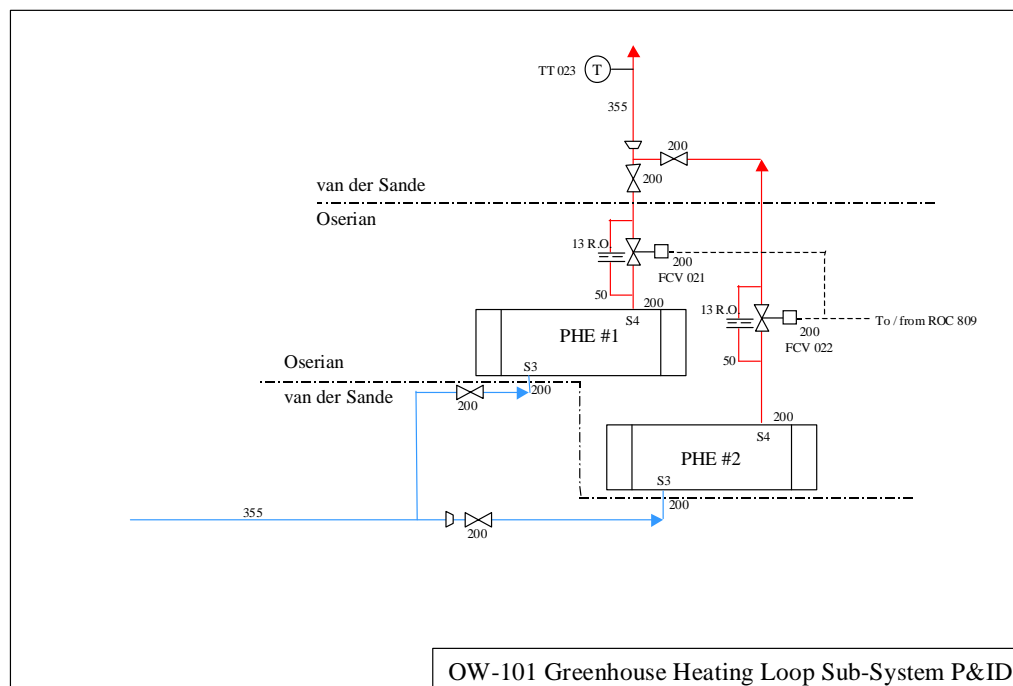

FIGURE 4: P&ID for greenhouse heating loop sub-system (at well site)

3.2 Fluid venting

Venting of the well flow has been allowed for, also by means of a high-performance ball valve. The three principal reasons for venting part or all of the flow are:

- Venting of high well flow rates;
- Avoiding high wellhead pressures (hence back-pressuring of the well) by maintaining some flow; the well can be extinguished at wellhead pressures in the range 10 to 15 bars (abs.);

- Venting well flow to waste when heating is not required (the well needs to be kept flowing, otherwise it can take some time to re-start after being closed in).

In relation to this last point, initially four (4) greenhouses of 1 hectare in area were connected to the system, requiring only 4 hours per day of heating system operation. Currently forty 1 hectare greenhouses are heated using the system which is therefore operating continuously.

3.3 Heat exchangers

A standard design of titanium plate heat exchangers were chosen for compactness, ease of maintenance, ease of shipment, and availability. In addition, plates can be added or removed to accommodate possible long-term changes in well output.

Because of the well's cycling flow, two identical exchangers were selected to maintain (as much as practicable) steady heat transfer conditions. As may be seen in Figure 1, the well operates for a significant proportion of time spent at low to moderate flows. One heat exchanger is used when the heat supply from the well is less than about 10 MWt, otherwise two are used. Thus, the second exchanger can accommodate the flow cycling (which is a short-term effect). Two parallel exchangers also provide redundancy; if necessary one exchanger can readily perform most of the heating, except at the peak of the cycle.

In opting for two exchangers, it was necessary to ensure that a minimum flow was maintained in the unused exchanger. This avoids stagnation of geothermal fluid, and was achieved by having by-pass flows of both geothermal fluid and secondary water via small orifice plates.

3.4 Condensate & non-condensable gases separation

The heat exchanger(s) condense virtually all of the steam in the two-phase fluid provided by OW-101. A knock-out drum is provided after the heat exchangers to separate the non-condensable gases from the liquid phase. The pressure in the knock out drum is controlled to a set value (related to the pressure upstream of the heat exchangers), and CO₂ from the knock-out drum is diverted to the air enrichment system and/or discharged to waste, depending on the greenhouse CO₂ demand.

3.5 Fluid disposal

Fluids vented via the vent line, and the separate flows of non-condensable gas and liquid (brine combined with steam condensate) from the knock-out drum, are discharged into a vent silencer. Steam and gases are thence vented to atmosphere, and liquids to the existing discharge area.

3.6 Control system

The geothermal heating sub-system is controlled by a stand-alone Remote Operations Controller (ROC), which provides PID loop control, monitoring and alarm indication, logging of process parameters, and control interfacing with the greenhouse heating control system. The ROC is provided with mains and battery back-up power supplies.

The geothermal fluid control is largely independent from the heating system controller, but certain on/off signals need to be exchanged; these are for heating on/off, and CO₂ on/off. The ROC signals which pumps are to be run, based upon which heat exchanger(s) are in heating mode. The controls for the system are designed to be fail-safe; ensuring that equipment is protected while at the same time keeping the well flowing.

3.7 Mechanical design aspects

The following are the key features of the mechanical design and construction of the geothermal heating sub-system:

- Piping designed to ANSI/ASME B31.1;
- Over-pressure protection provided by bursting disks;
- Knock-out drum fabricated from pipe sections and hydrotested;
- Heat exchangers operate at low pressure;
- Carbon steel piping, except that stainless steel type 316L is used for pipe from the heat exchangers to the knock-out drum, the knock-out drum itself, and the NCG and condensate pipes downstream of the knock-out drum;
- Typical sliding pipe supports are used, which provide for movement due to thermal expansion;
- Concrete vent structure, incorporating discharge chamber and impingement plate in stainless steel 316L.

4. CONCLUSION

At the time that this paper was originally written, the heating system was under construction. Initially the system was connected to four (4) greenhouses, each 1 hectare in area. Subsequently, the system has been expanded and now supports forty (40) 1 hectare of greenhouses, with an additional ten (10) 1 hectare greenhouses currently under construction.

In 2005 Oserian farm installed a 1.2 MWe Ormat binary generation plant on another Olkaria West exploration well – OW-306 which now provides Oserian with an independent electricity source primarily used to support the farms very large water pumping requirements.

In addition to utilising the separated non-condensable gases produced by well OW-101, the separated non-condensable gases from the nearby OrPower 4 (Ormat) 12 MWe plant is piped to the farm area, diluted with air and distributed through the greenhouses.

ACKNOWLEDGEMENTS

The authors wish to thank Oserian Development Company and, in particular its Chairman, Mr. Hans Zwager, for permission to present this paper. Mr. Zwager has long promoted and pursued the use of geothermal energy for heating. While others have made use of geothermal surface features to capture steam, the use of the geothermal resource tapped by well OW-101 is the only known direct use of deep geothermal energy in Kenya, and under Mr. Zwager's leadership the use of this well has been expanded. Mr. Zwager is to be regarded as a pioneer of geothermal direct use in Kenya.

The early exploration work by the Kenya Power Company (now the Kenya Electricity Generating Co. Ltd - 'KenGen') and others is also acknowledged. Although well OW-101 has little practical capability for power generation, its current use for heating demonstrates that exploratory efforts can have tangible and useful benefits, even for relatively unattractive wells such as OW-101. The benefits include the use of a naturally occurring energy source, and the environmental benefit of avoiding the use of fossil fuels.

BIBLIOGRAPHY

Melaku, M., Thompson, S., Mills, T., 1995: Geothermal heat for soil sterilisation. *Proceedings of the World Geothermal Congress 1995, Florence, Italy*, 4, 2281-2284.