



UNITED NATIONS
UNIVERSITY

UNU-GTP

Geothermal Training Programme

Orkustofnun, Grensasvegur 9,
IS-108 Reykjavik, Iceland

Reports 2015
Number 18

TOPPING UNIT AT OLKARIA IV GEOTHERMAL POWER PLANT, NAIVASHA, KENYA

Reuben Kipngeno Langat

Kenya Electricity Generating Company Ltd. - KenGen

P.O. Box 785-20117, Naivasha

KENYA

rklangat@kengen.co.ke, ruben.langat@gmail.com;

ABSTRACT

A study on the optimization of the current set up of Olkaria IV geothermal power plant by utilizing high-pressure fluid is presented. The study is applied on the Olkaria IV geothermal wells to determine the additional electrical energy output that could be generated. A total steam mass-flow of 280 kg/s is passed through a back-pressure turbine acting as a topping unit, operating between 11.8 bar absolute inlet pressure and 6 bar absolute exhaust pressure. Thermodynamic cycle model simulation done using Engineering Equation Solver (EES) shows that 10-26 MW of electricity can be produced in the topping unit assuming turbine isentropic efficiency of 85%. The additional gross power generated will also provide environmental benefits. The application of the proposed model can help to utilize the untapped geothermal energy without additional drilling costs, thereby increasing the profitability of the operating plants.

1. INTRODUCTION

1.1 General background

Renewable energy is a priority in today's global energy outlook due to drastically increasing prices of fossil fuels and associated greenhouse gas emissions. Geothermal energy is considered to be an attractive renewable energy option. It originates from the thermal energy present in the Earth's crust. Geothermal energy has been used since ancient times in many countries in the world, mainly used for bathing, cooking and washing. Current applications of geothermal energy include electricity production, district heating, green house farming, fish farming, drying, snow melting, and others (Geirdal, 2013). Commercial electricity power generation from geothermal power plant started in 1914 when a 250 kW unit at Larderello, Italy provided electricity to the nearby cities of Volterra and Pomarance (DiPippo, 2007). Since then, many geothermal power plants have been installed. There are many aspects that make electricity production from geothermal energy to be feasible technically, economically and environmentally such as high availability, high capacity factor, ability to be used as a base load, low operational and maintenance cost, and low CO₂ emissions.

Geothermal power plants can be divided into two main groups based on the enthalpy of the geothermal fluid: those that utilise steam cycles which are used at higher fluid enthalpies and binary cycles for lower enthalpies. In steam cycles, the geothermal fluid from liquid-dominated reservoirs boils partly due to

flashing in the wells, the steam is then separated from the brine and finally expanded in a turbine to produce work. Usually the brine is released into the environment (e.g. re-injected to the reservoir or released onto the surface), or it can be flashed again at a lower pressure. The first type of cycles in which the fluid boils and the brine is separated at a high pressure and then rejected directly to the environment is called single flash cycle (SF), and the second type in which the brine is flashed again at a lower pressure is called double flash cycle (DF). A binary cycle uses a secondary working fluid in a closed power generation cycle. A heat exchanger is used to transfer heat from the geothermal fluid to the working fluid, and the cooled brine is then released into the environment or reinjected back into the ground. The organic Rankine Cycle (ORC) and Kalina cycle, used to exploit low to medium enthalpy geothermal resources are both binary cycles.

Geothermal resources have been classified as low, intermediate or high-enthalpy resources according to their reservoir temperatures. The temperature ranges used for these classifications are arbitrary and they are not generally agreed upon (Lee, 1996). Temperature is used as the classification parameter because it is the easiest to measure and understand. In addition, temperature or enthalpy alone can be ambiguous defining a geothermal resource because two independent thermodynamic properties are required to define the thermodynamic state of the fluid. Geothermal energy exists in the form of heat, which is a low grade form of energy and work is a high grade form of energy, and from the Second Law of Thermodynamics, all work can be converted into heat but not vice versa. Therefore, geothermal resources should be classified based on exergy, a measure of the amount of maximum work that can be produced from a given heat source. (DiPippo, 2007). Exergy analysis can be done for all components of the power plant to identify the exergy efficiencies or sometimes called Second Law efficiencies or utilization efficiencies.

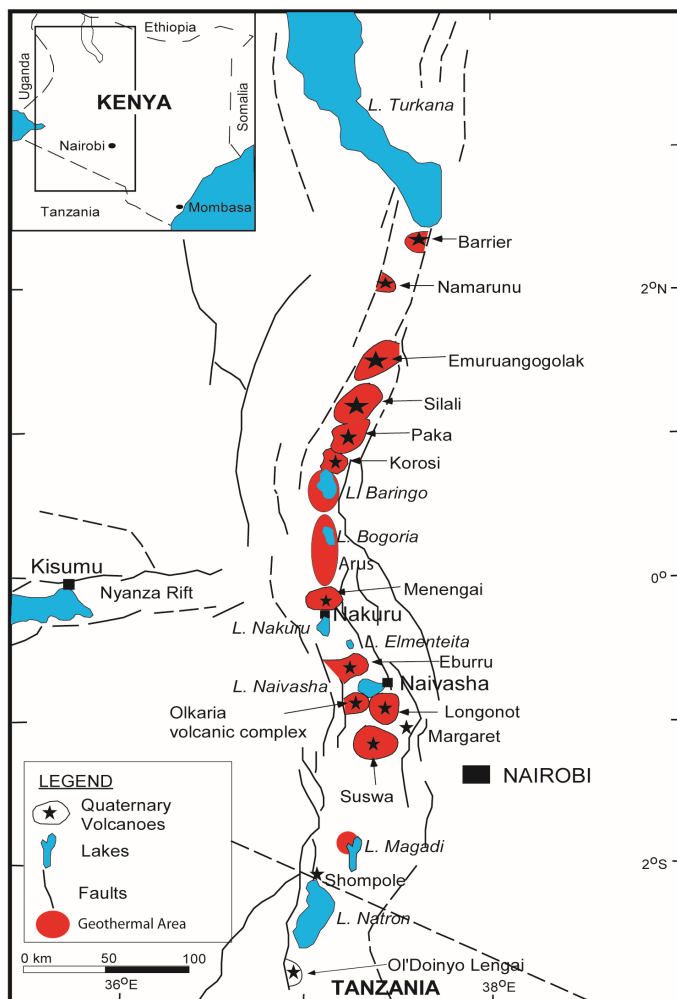

FIGURE 1: Map of Kenya showing the location of Olkaria geothermal area (Langat, 2004)

1.2 Area of study

The Olkaria geothermal system is one of the several geothermal systems along Kenya's rift valley as shown in Figure 1. The geothermal system is related to plate tectonics involving faulting and rifting of the continental plate and the resulting volcanic activity during the formation of the African rift valley. Fluid flow and hydrothermal features in the field are mainly controlled by faults (Langat, 2004). The heat sources to the systems are magmatic intrusions located at depths of 5-8 km. The geothermal reservoir is a high-temperature liquid-dominated type with reservoir temperature ranging from 200-340°C and an average of 230-260°C. The chemistry of the fluids shows chloride waters with alkaline pH and low total dissolved solids (TDS) and bicarbonate content. Chloride concentrations range from 100 to 1100 ppm and the non-condensable gases (NCG) are about 0.25% of the steam (Karingithi, 2002).

The Olkaria IV Domes geothermal field is located in the Olkaria geothermal field which is one of the seven geothermal fields

that make up the Olkaria geothermal system. It lies within an approximately circular 17 km² area as shown in Figure 2 and now has one power plant (Olkaria IV) with an installed capacity of 140 MWe which is owned and operated by Kenya Electricity Generating Company Ltd, (KenGen). Other power plants in the greater Olkaria field are Olkaria I with an installed capacity of 45 MWe, Olkaria II with an installed capacity of 10 MWe, Olkaria IAU units 4 & 5 with an installed capacity of 140 MWe and Olkaria III, owned by Ormat, and has an installed capacity of 148 MWe.

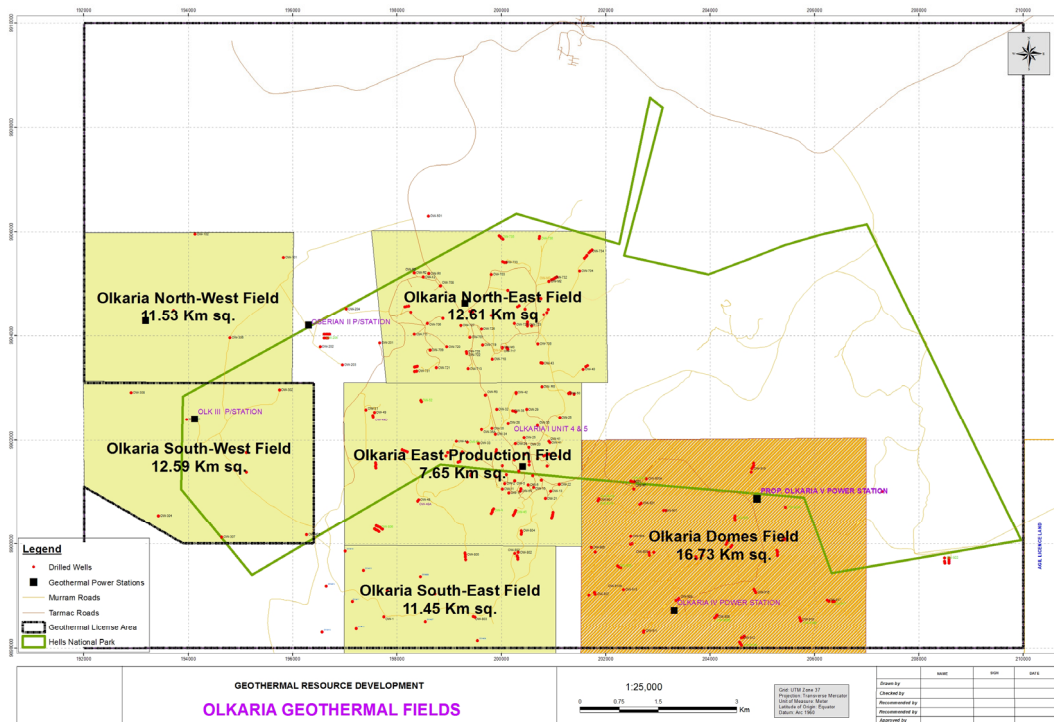

FIGURE 2: The Olkaria geothermal fields

The idea behind the model proposed in this study is the addition of a non – condensing turbine, commonly known as a back pressure turbine unit. This can be installed into the existing system instead of reducing pressure by the process of throttling using a pressure reducing valve, i.e. Pressure Reducing Valve (PRV), in order to further utilize the geothermal energy of the resource that has been harnessed in the high-pressure system of separation stations, and connected to the Olkaria IV power plant through a network of separation stations, namely SD1, SD2 and SD3. The motivation behind this project is to increase the overall efficiency when utilizing the high-pressure steam from the field. Data obtained over the years have shown significant stability of the well pressures in this field.

1.3 Literature review of topping units

The design inlet pressure for condensing steam turbines is often below 8 bar-a pressure, however some of the geothermal well fields produce steam at much higher pressure than required for the condensing steam turbine, which could be considered as unused energy. In this situation, the steam pressure must be reduced to the required inlet pressure of the turbine. Usually, the inlet pressure of the condensing steam turbines is fixed and it cannot be increased, and therefore the need of using a back-pressure turbine to extract this unused energy and to reduce the pressure has become attractive.

The technology of using a back-pressure turbine to extract energy from the excess steam pressure in condensing turbine geothermal power plants, which is sometimes called topping unit, was used in the Leyte Geothermal Optimization Project in the Philippines in 1997, and was done by ORMAT as a EPC turnkey contract. The project consisted of four individual power plants, three of which used a topping unit and the fourth one which used another technology called a bottoming unit. The total net power

gained by using this technology was 49 MW which represented almost 10% of the total installed capacity of the four power plants of 502.5 MW. The net power gained was 35.65 MW from topping units and 13.35 MW from the bottoming unit. The three power plants that used topping units are: Tongonan Power Plant, Mahanagdong A and Mahanagdong B (Kaplan and Schochet, 2000).

Tongonan topping plant

The total installed capacity of the main Tongonan Power Plant is 112.5 MW. The inlet pressure of the plant is 6.83 bar-a with flow of 1008 tons/hr and the steam pressure from well field is 11.14 bar-a. The ORMAT topping units were added to generate maximum power while reducing the pressure from 11.14 to 6.83 bar-a. The topping unit consisted of two 3.25 MW back-pressure turbines with high efficiency and reliability and were easily installed. Each turbine was directly coupled to each side of a generator. The Tongonan Topping Plant has three topping units generating 16.95 MW net power (Kaplan and Schochet, 2000).

Mahanagdong A topping plant

The total installed capacity of the main Mahanagdong A Power Plant is 120 MW. The inlet pressure of the plant is 6.83 bar-a with flow rate of 817 tons/hr while the resource pressure is 10.8 bar-a. The ORMAT topping units were added to generate maximum power while reducing the pressure from 10.8 to 6.8 bar-a. The Mahanagdong A Topping Plant consists of two topping units generating 12.45 MW net output (Kaplan and Schochet, 2000).

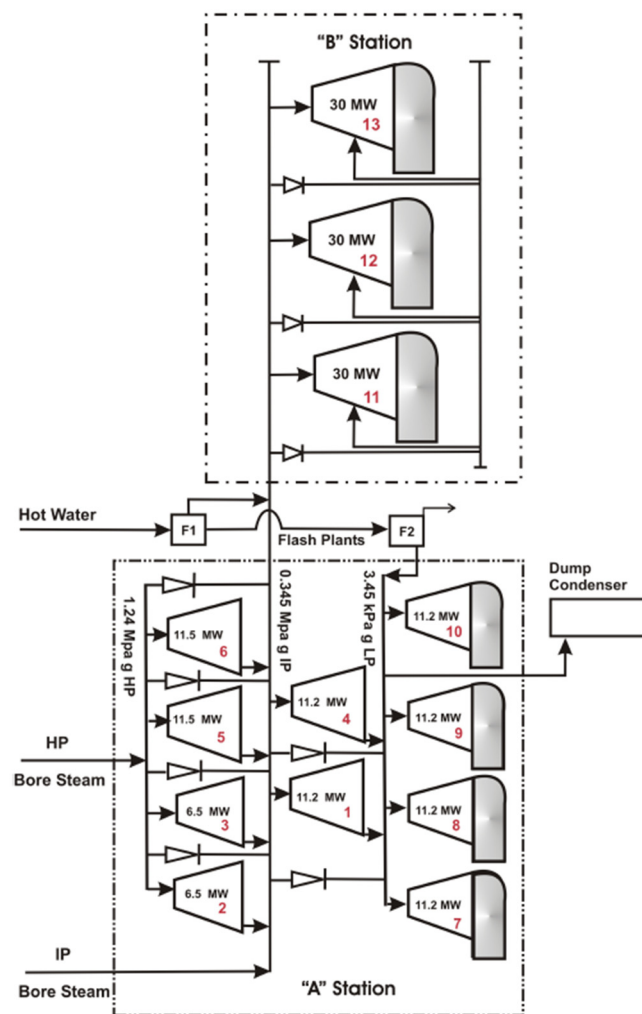

FIGURE 3: Schematic diagram of Wairakei power plant (Thain and Carey, 2008)

Mahanagdong B topping plant

The total installed capacity of the main Mahanagdong B Power Plant is 60 MW. The inlet pressure of the plant is 6.83 bar-a and the resource pressure is 10.8 bar-a. The ORMAT topping unit was added to generate maximum power while reducing the pressure from 10.8 to 6.8 bar-a. The Mahanagdong B Topping Plant consists of one topping unit generating 6.25 MW net (Kaplan and Schochet, 2000).

The total net power gained from the three topping plants is 35.65 MW (Kaplan and Schochet, 2000).

This technology has also been used in Wairakei Power Project, New Zealand in 1956 when it was redesigned by replacing the machines of a heavy water distillation plant with new turbines. Wairakei Geothermal Power plant had a total capacity of 47 MW. The redesign resulted in an implementation of a new plant called B station beside the old plant which is called A station and addition of new turbines in A station itself.

Wairakei A station

This plant consists of three pressure levels: high pressure, intermediate pressure and low pressure as shown in Figure 3. The high pressure is 13.5 bar-a which enters two 11.5 MW turbines and two 6.5 MW turbines, and exits at 4.45 bar-a intermediate pressure and is

then collected in the intermediate pressure manifold. The steam from the intermediate pressure manifold goes through two branches to the intermediate pressure turbines and to the B station. Two 11.2 MW intermediate pressure turbines receive steam at 4.45 bar-a and exit pressure of 1.0345 bar-a. The steam at 1.0345 bar-a enters four 11.2 MW low pressure turbines which are condensing turbines with exit pressure below vacuum (Thain and Carey, 2008).

Wairakei B station

The Wairakei B station consists of three 30 MW condensing turbines. The turbines work at an intermediate pressure of 4.45 bar-a inlet pressure and exit pressure under vacuum. The turbines also accept the pass- in steam from low pressure at 1.1 bar-a (Thain and Carey, 2008).

The total installed capacity of Wairakei geothermal power plant increased from 47 MW to 193.2 MW which is 103.2 MW from A station and 90 MW from B station as in Table 1 (Thain and Carey, 2008).

TABLE 1: Wairakei units rating (Thain and Carey, 2008)

Type	Units	MWe
High pressure (HP)	G2, G3	6.5
High Pressure (HP)	G5, G6	11.5
Intermediate pressure (IP)	G1, G4	11.2
Low pressure (LP)	G7, G8, G9, G10	11.2
Mixed pressure (MP)	G11, G12, G13	30

2. CURRENT STATUS IN OLKARIA IV

2.1 Current operations

Olkaria IV 140 MWe geothermal power plant is one of the two largest power plants in Kenya, the other one being Olkaria 1 additional Units, with installed capacity of 140 MWe.

Electricity generation in Olkaria IV started in September 2014 when two 70 MWe turbines were commissioned and complete commercial operation was achieved in December 2014. There are plans to increase the capacity by adding extra units in the future. The turbines installed are produced by Toshiba, low-pressure turbines with steam requirement of 504 tons/hr and 5.2 bar-a inlet conditions and an exit pressure of 75 mbar absolute.

The steam is collected from wells in the Olkaria Domes field through a network of four separation stations, SD, named as SD1, SD2, SD3 and SD4 (Figure 4) (Brookes, 2011).

The separator stations comprise a series of vertical modular separators (Figure 5), design to separate two-phase steam at 11.8 bar-a pressure. The separated steam is then piped to a common header that leads to the final steam scrubber vessel before being admitted to the main turbine of the main plant.

During the design phase it was recognised that the separation pressure needed to be higher because of the risk of scaling. At that time the steam system was designed for a pressure of 13.5 bar for the separators and the steam piping. The decision was then made to install pressure let down stations (PLDS) at Olkaria IV to increase the steam field pressures much as possible, given the pressure limitation of the separators and steam piping. The PLDS are now operational, and the design separation pressure increased to around 12.2, 11.8, 11.8 and 12.3 bara for SD1, SD2, SD3 and SD4 respectively. The pressure upstream of the Olkaria IV PLDS is between 10.0 and 10.5 bar (KenGen, 2011).

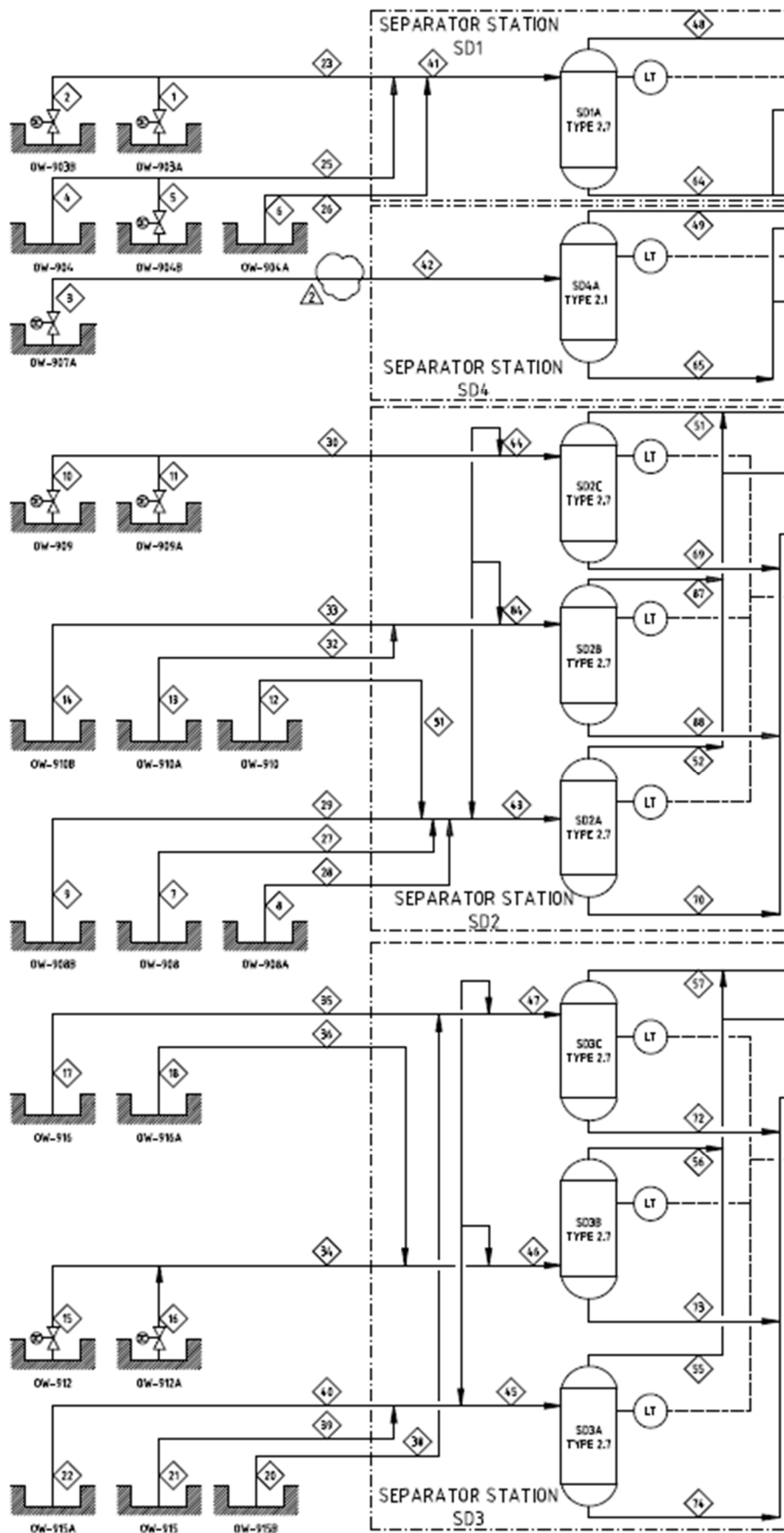

FIGURE 4: Modular separation stations

2.2 Modular separation stations

The steam is collected from the wells in the steam field and is separated in a common central separator station that serves multiple production well pads. The advantage in this modular separation is that the variation between design data and actual production flows in one well's output may be balanced by variations in the outputs of other wells. Figure 5 shows a schematic diagram of a modular separation station.

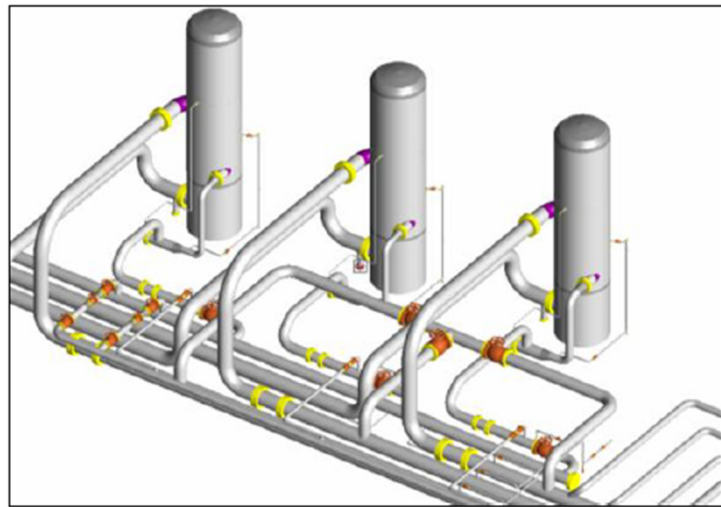

FIGURE 5: Typical modular separation station

Figure 6 shows the well locations, pipe routes, the separator stations and the site of the existing power plant. The two-phase fluid is gathered and conveyed to the common primary modular separators in Figure 5, located near the power plant.

For the gathering of the two-phase geothermal fluid, proper evaluation was made to find the optimum diameter of pipe by optimizing pipe routes in order to minimize the loss of electricity production due to corresponding pressure drop due to frictional losses. The power station site, as seen on the geographic map of Olkaria IV power plant, is at a lower elevation than the separator stations SD2 and SD3, so the

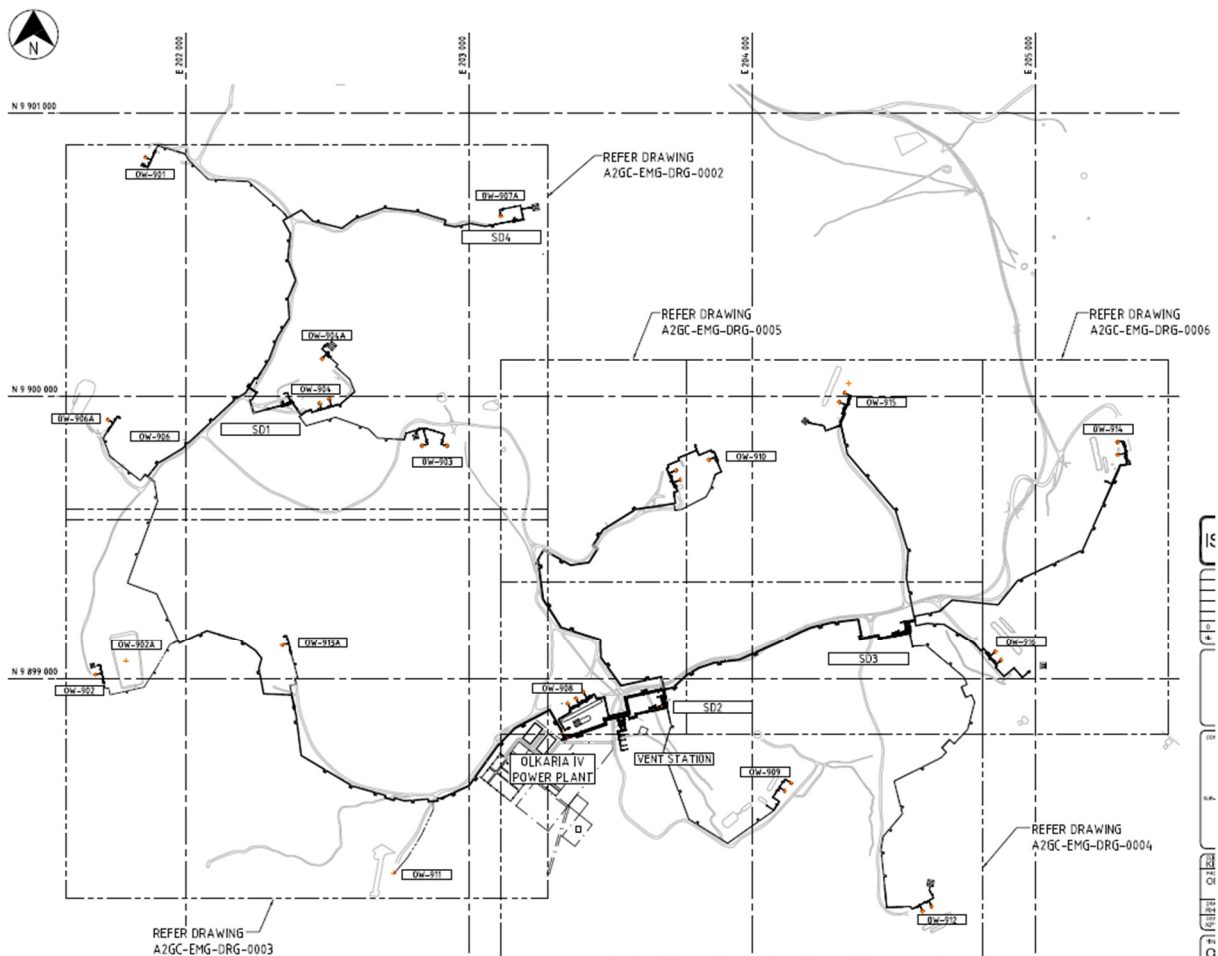

FIGURE 6: Wells locations and pipe routes

fluid gains static head. The static head gain would compensate for the acceleration head loss, however that effect is neglected, so for the two-phase flow calculation of the pipe loss, only the frictional pipe loss is taken into account and not the compensation due to elevation differences. The steam field pressure drops are not considered in this report. Figure 7 shows the existing Olkaria IV power plant as well as the location of SD3 separator station. PLDS and the vent station are located in the vicinity of the power plant. This will be the area where the project for developing the topping unit is planned.

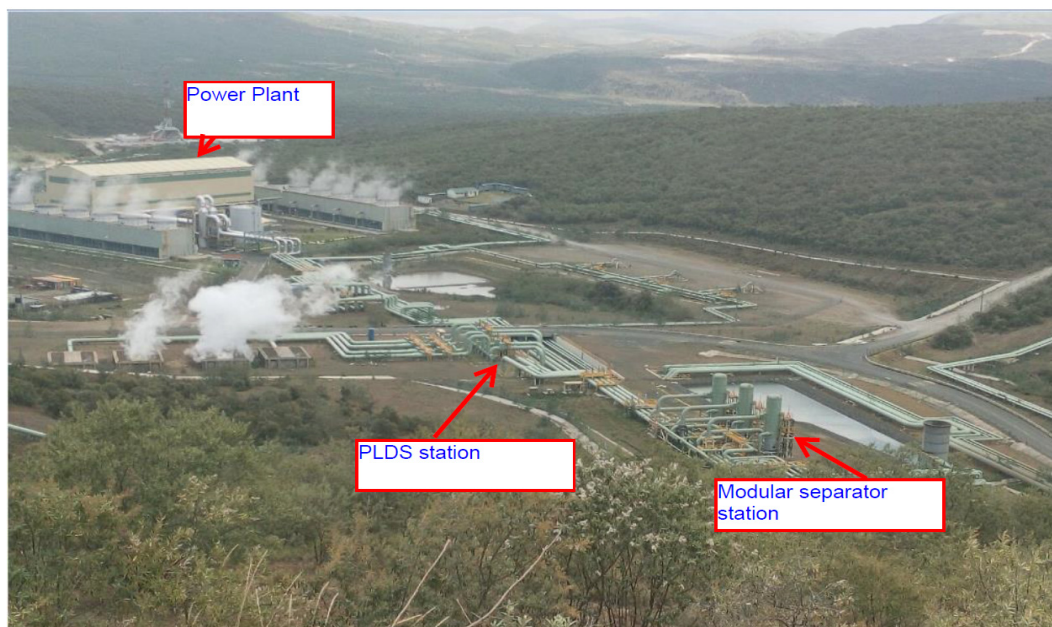

FIGURE 7: Existing Olkaria IV power plant

From the data available on the wells considered, it is clear that the geothermal fluid can be separated at different pressures than the design pressure of the current separator stations, and to meet the power plant inlet steam pressure of 5.2 bar gauge pressure. It is therefore of interest to investigate the feasibility of installing a high pressure topping with back pressure turbine that will exhaust to a new low-pressure separation station to be used in the main power plant downstream. The backpressure turbine is expected to be permanently installed and to be in operation for the life span of the power plant.

3. PROPOSED MODELS

3.1 Introduction

This study aims to analyse the amount of electrical power output that could be obtained from using a back pressure turbine which could be installed after the separator stations to lower the high separation pressure to a pressure closer to the main turbine inlet pressure. It will also compare the benefits of using this back pressure turbine instead of using throttling valve or a Pressure Let Down Stations, PLDS. The schematic arrangement of options available in connecting high-enthalpy wells is presented in Section 3.3.

3.2 Basic design data

The developmental plan for every power plant starts by analysing the available basic resource data. When considering geothermal resources, it is customary to evaluate the condition of the fluid and output characteristics of each well before designing the power plant. This is performed with the available resources at hand or with assumptions based on related studies. The well test data are reviewed in order

to form a list of well production characteristics. Table 2 shows the discharge test results of wells in consideration for the topping plant (KenGen, 2012)

TABLE 2: Well data output

Separator station	Well no.	WHP	Two-ph	Enthalpy	Min H	Max H	Steam	Brine
		bara	t/h	kJ/kg	kJ/kg	kJ/kg	t/h	t/h
SD1A	W-1	13.0	65	1700	1650	1740	29.4	35.6
SD1A	W-2	13.3	65	1450	1375	1550	21.2	43.8
SD1A	W-3	16.1	90	1425	1375	1475	28.3	61.7
SD1A	W-4	13.0	120	1275	1240	1330	28.6	91.4
SD1A	W-5	12.6	57	1625	1550	1700	23.7	33.3
SD4A	W-6	12.6	95	1750	1650	1800	45.4	49.6
SD2A	W-7	14.9	30	2200	2130	2250	21.2	8.8
SD2A	W-8	17.5	115	1420	1380	1470	36.1	78.9
SD2A	W-9	14.7	87	2050	2000	2100	54.9	32.1
SD2C	W-10	12.9	130	2000	1900	2100	78.8	51.2
SD2C	W-11	12.4	100	1820	1700	1870	51.5	48.5
SD2A	W-12	18.3	60	1950	1900	2000	34.8	25.2
SD2B	W-13	18.1	110	2250	2150	2350	80.5	29.5
SD2B	W-14	18.6	210	2000	1700	1900	127.3	82.7
SD3B	W-15	12.6	40	1950	1900	2000	23.2	16.8
SD3B	W-16	12.6	64	2520	2480	2575	55.5	8.5
SD3C	W-17	14.0	130	2475	2425	2550	109.8	20.2
SD3B	W-18	13.4	65	2150	2050	2250	44.3	20.7
SD3A	W-19	16.3	75	2070	1900	2150	48.1	26.9
SD3A	W-20	15.3	110	2450	2375	2525	91.5	18.5
SD3C	W-21	15.4	105	2200	2150	2250	74.1	30.9
	Total		1923				1108	815

There are four modular separation stations, with two main ones being SD2 and SD3. The other two separator stations SD1 and SD4 are meant to tie in steam to the main steam headers to make sure adequate steam is available for the main steam turbines. Table 3 shows the separation pressures and the steam mass flow from all the separators.

The mass flow from the separator stations in Table 3 has been used to determine the total two-phase flow rate that would be required to pass through the high-pressure separator station in order to meet the main plant steam inlet requirement. It is therefore of interest to investigate the feasibility of installing high-pressure separation stations that use a back pressure turbine that will exhaust to lower pressure to be used in the main power plant downstream.

TABLE 3: Separator stations separation pressures and basis flows

Separator	Inlet P	Sep DP	Outlet P	Outlet T	2P flow	Enthalpy
	(bara)	(bara)	(bara)	(degC)	(t/h)	(kJ/kg)
SD1A	12.22	0.08	12.14	188	397	1457
SD2A	11.82	0.10	11.72	187	292	1797
SD2B	11.82	0.10	11.72	187	320	2086
SD2C	11.82	0.10	11.72	187	230	1922
SD3A	11.93	0.09	11.84	187	185	2296
SD3B	11.93	0.09	11.84	187	169	2243
SD3C	11.93	0.09	11.84	187	235	2352
SD4A	12.26	0.02	12.24	189	95	1750

In this report, six options are discussed and compared:

1. The single flash, with current operation set up;
2. The single flash with back pressure topping unit;
3. The double flash system with back pressure topping unit;
4. The double flash system and back pressure topping unit with a mist eliminator;
5. The optimized case of scenario 3 mentioned above with main turbine inlet pressure fixed;
6. The optimized case of scenario 3 with both high and low separator pressures optimized.

3.3 Options selection

The options selected are all based on the current status where all the wells are separated in common modular separator stations. The steam obtained is that of the main steam turbine with a steam inlet requirement of 280 kg/s.

3.3.1 Current operations

The current operations setup is such that steam is collected from a steam gathering system and transported to a modular separation stations at four different locations named SD1, SD2, SD3 and SD4, with separation pressures of 11.8 bar-a for both SD2 and SD3 and 12.2 bar-a and 12.3 bar-a for SD1 and SD4 respectively. SD2 and SD3 are located close to the power plant while SD1 and SD4 are located about 1 km away from the power plant and are mainly meant to provide steam to tie into the main steam headers coming from SD2 and SD3.

The steam is separated at a high pressure of 11.8 bar-a and then conveyed to the main steam headers in the pressure let down stations (PLDS) installed with pressure reducing valves (PRVs) to reduce the pressure to the design inlet turbine pressure of 5.2 bar gauge.

There are two steam turbines installed at Olkaria IV, each with a steam inlet pressure of 5.2 bar gauge and a steam consumption of 140 kg/s. The maximum power output is 70 MWe at a nominal continuous rating (NCR) for one turbine. In this report, both steam turbines are considered as one and so the total steam requirement would be 280 kg/s for a power generation of 140 MW. Figure 8 shows a process flow diagram of the setup.

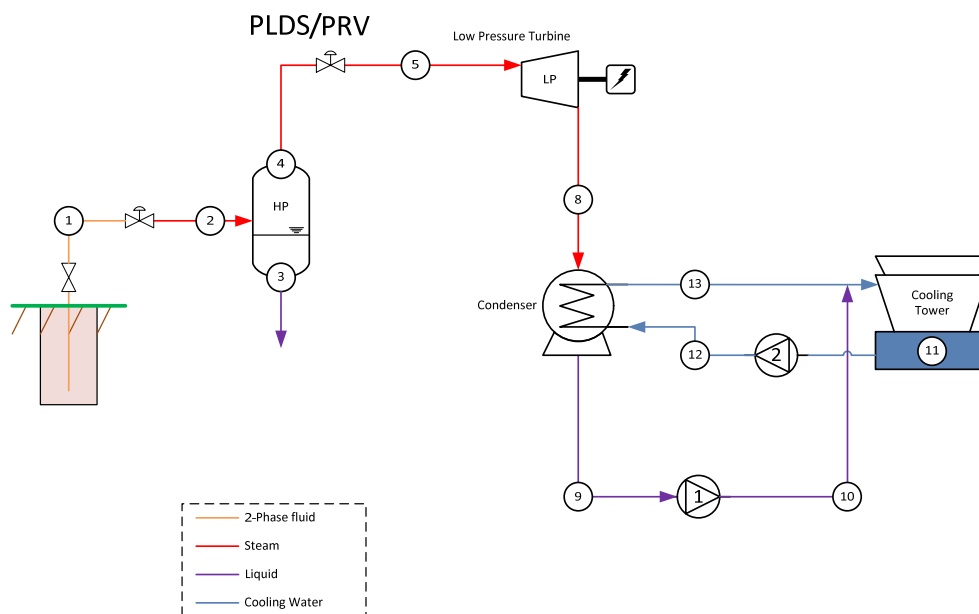

FIGURE 8: Schematic flow diagram of current operations

3.3.2 Single flash with a back pressure topping unit, case 1

The first proposed model is to modify the current operation setup to include a back pressure turbine installed immediately after the separator stations as shown in Figure 9. The back pressure turbine will act as a pressure reducing valve in the process of isentropic expansion of total steam, while at the same time generating electrical power.

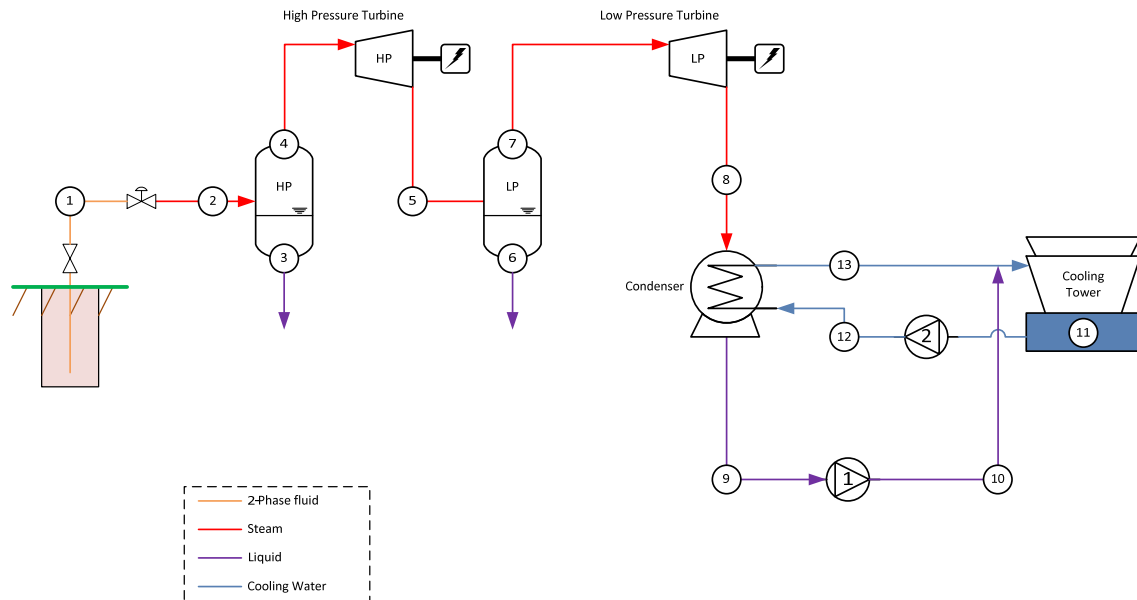

FIGURE 9: Schematic flow diagram, case 1

A mist eliminator is installed to remove any droplet that would have condensed during the expansion in the back pressure turbine.

3.3.3 Double flash system with a back pressure turbine, case 2

In this model, the back pressure turbine is installed after the separation station similar to case 1. The brine from the high-pressure separation station is combined with the exhaust steam from the back pressure turbine to be flashed again at a new low-pressure separation station. The steam obtained from the low-pressure separator is then conveyed to the existing low-pressure steam turbine (Figure 10).

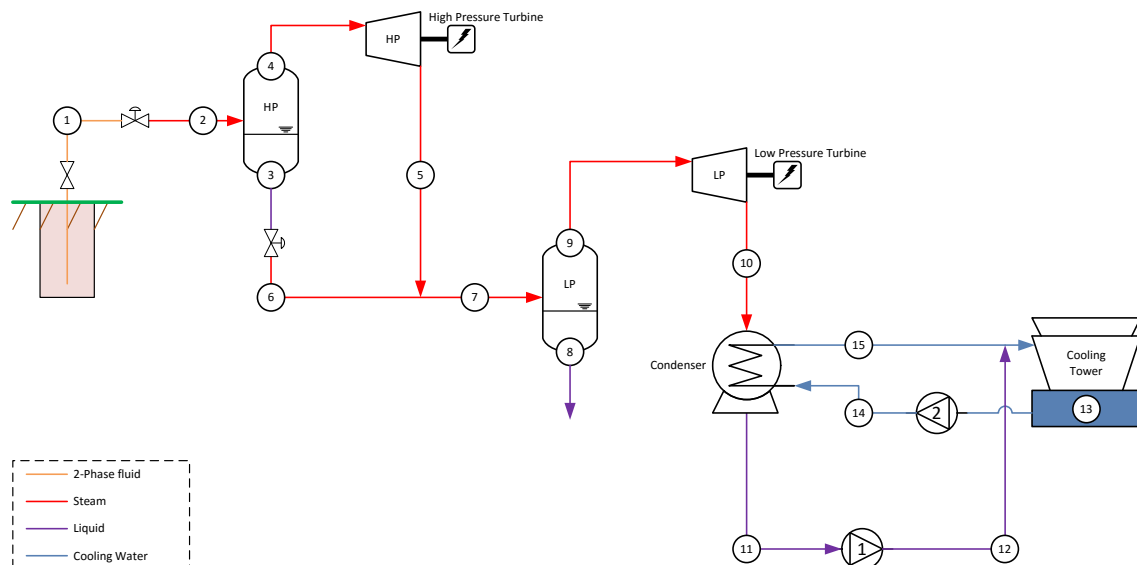

FIGURE 10: Schematic flow diagram, case 2

The arrangement of equipment above includes: several valves, piping and instruments (pressure and temperature gauges). If wellhead separators are used, the cyclone separator (CS) will be located close to the wellhead on the same pad. For this report, a modular separator station is presented.

The processes undergone by the fluid are shown in Figure 13. The wells produce saturated steam as well as saturated water (or slightly superheated steam), so the starting point (state 1) is located on the saturated vapour curve. If the steam is superheated, point 1 moves slightly to the right. The turbine expansion process 1–2 generates somewhat less power output than the ideal, isentropic process 1–2s. Heat is rejected to the surroundings in the condenser via the cooling water in process 2–3.

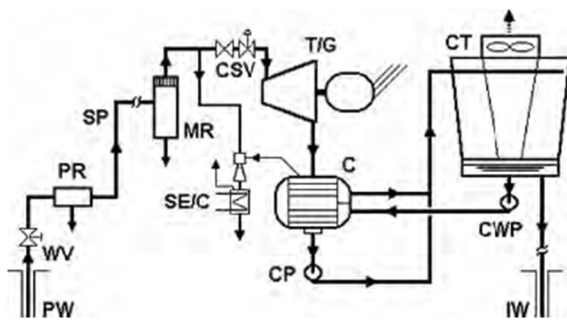

FIGURE 12: Simplified single-flash power plant schematic (DiPippo, 2007)

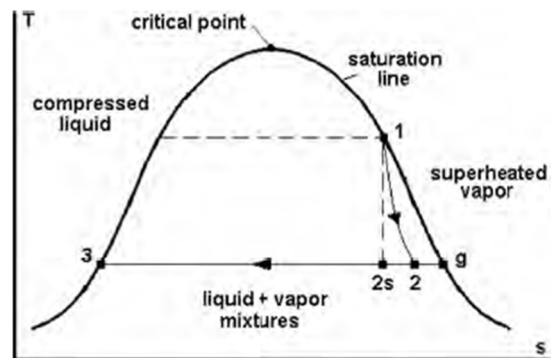

FIGURE 13: Temperature-entropy diagram for a dry steam plant with saturated steam at the turbine inlet (DiPippo, 2007)

4.2 Turbine expansion process

The work produced by the turbine per unit mass of steam flowing through it is given by Equation 1:

$$W_t = h_1 - h_2 \tag{1}$$

where W_t = Work done by the turbine;
 h_1 = Enthalpy of steam at turbine entry;
 h_2 = Enthalpy of steam at turbine exit.

It is assumed that the turbine is expanding adiabatically thus the changes in kinetic and potential energy of the fluid entering and leaving the turbine are neglected. The maximum possible work would be generated if the turbine operated adiabatically and reversibly, i.e. at constant entropy, that is isentropically.

The isentropic turbine efficiency, η_t , is the ratio of the actual work to the isentropic work, and is given by Equation 2:

$$\eta_t = \frac{h_1 - h_2}{h_1 - h_{2s}} \tag{2}$$

where η_t = Isentropic turbine efficiency;
 h_1 = Enthalpy of steam at entry;
 h_2 = Enthalpy of steam at exhaust;
 h_{2s} = Enthalpy of steam at saturated state.

The power developed by the turbine is given by Equation 3:

$$\dot{W}_t = \dot{m}_s W_t = \dot{m}_s (h_1 - h_2) = \dot{m}_s \eta_t (h_1 - h_{2s}) \tag{3}$$

where \dot{m}_s = Steam mass flow rate

The gross electrical power will be equal to the turbine power times the generator efficiency and is given by Equation 4:

$$\dot{W}_g = \eta_g \dot{W}_t \quad (4)$$

where \dot{W}_g = Gross electrical power;
 η_g = Generator efficiency.

The net power is the gross electrical power reduced by all parasitic loads, including condensate pumping power, cooling tower fan power, and station lighting.

Since there is degradation in performance of a wet steam turbine, the Baumann rule as given below is applied:

$$\eta_{tw} = \eta_{td} X \left[\frac{1 + X_2}{2} \right] \quad (5)$$

where the dry turbine efficiency, η_{td} may conservatively be taken to be constant at 85%, η_{wd} is the wet turbine efficiency and X_2 is the dryness fraction.

Taking into account that the steam present inside the turbine is not 100% dry then according to the Baumann rule, the enthalpy exiting the turbine is given by Equation 6:

$$h_2 = \frac{h_1 - A \left[1 - \frac{h_3}{h_g - h_3} \right]}{1 + \frac{A}{h_g - h_3}} \quad (6)$$

where h_3 = Total two-phase flow;
and the factor A is defined as:

$$A = 0.425 (h_1 - h_{2s}) \quad (7)$$

where the subscript numbers indicate the state points and the associated subscript letters 'g' and 's' are the steam phase and the isentropic state values, respectively.

4.3 Optimum well head pressure

The scenario of the optimum wellhead pressure for a dry steam plant receiving saturated vapour at the wellhead is considered. It is assumed that the pressure losses in pipelines are negligible. It is also assumed that the pressure of the wellhead can be controlled by means of a throttle valve. Then the well productivity curve can be approximated as an elliptical equation for the mass flow rate of steam as a function of the wellhead pressure as in the Equation 8:

$$\left[\frac{\dot{m}}{\dot{m}_{max}} \right] + \left[\frac{P}{P_{ci}} \right]^2 = 1 \quad (8)$$

where \dot{m} = Total two-phase flow;
 \dot{m}_{max} = Maximum observed mass flow rate;
 P = Pressure;
 P_{ci} = Closed-in wellhead pressure.

Assuming that values for these two parameters are available from well tests, the mass flow rate at any pressure can be calculated from Equation 9, and a plot obtained as shown in Figure 14.

$$\dot{m} = \dot{m}_{max} \sqrt{1 - (P/P_{ci})^2} \quad (9)$$

Opening the wellhead valve will result in lower pressure, and higher flow rates, but the enthalpy of the steam will remain the same since it is a throttling process.

The turbine power is proportional to the product of the steam mass flow rate and the enthalpy drop Δh , as previously shown by the isentropic expansion of the turbine. There are two limits to the wellhead pressure; the closed-in pressure, P_{ci} , for which there is no steam flow, and the condenser pressure, P_c , for which there is no enthalpy drop. Thus the power vanishes at the two extreme positions for the wellhead pressure, indicating there is some wellhead pressure for which the power will be maximum. The power output per maximum steam flow rate is given by Equation 10:

$$\frac{\dot{W}}{\dot{m}_{max}} = \frac{\dot{W}}{\dot{m}} \times \frac{\dot{m}}{\dot{m}_{max}} = (h_1 - h_{2s}) \times \sqrt{1 - (P/P_{ci})^2} \quad (10)$$

where $h_1 - h_{2s}$ is the isentropic enthalpy drop across the turbine.

4.4 Pressure drops

4.4.1 Pressure drops in pipes

Pressure drop in two-phase geothermal pipelines consists mainly of static pressure drop, momentum pressure drop and frictional pressure drop. Several different methods for calculating the pressure drop in two-phase flow in pipelines have been proposed. Separated flow models are a class of commonly utilized models (Thome, 2006) for calculating the two-phase pressure drop; they employ two artificial pipes, one carrying the gaseous phase and the other the liquid phase. The resulting two-phase pressure drop is then calculated from the single-phase pressure drops. There is no analytical formula for solving the pressure drops of the two-phase flow in the pipe, however studies have shown two methods for calculating pressure drops in a two-phase flow. One is the homogeneous flow model where the two phases are treated as a single fluid and the other is the separate flow model where each phase is treated separately. The formula used for the pressure drop according to the homogeneous flow model is shown in the Equation 11:

$$\Delta P = \frac{2f_H L \dot{m}^2}{d \rho_H} \quad (11)$$

where L = Length of the pipe line;
 d = Internal diameter of pipe;
 \dot{m} = Total two-phase flow;
 f_H = Friction factor;
 ρ_H = Homogenous fluid density expressed in terms of the Reynolds number;
 \dot{m}_2 = Two-phase flow from production well.

The calculations on the two-phase pipe pressure drops in the pipe lines are not been presented in this report.

The location of the proposed topping plant shall be nearer to the separator station within a distance of 50 m. In this report it is assumed that there will be no pressure loss due to long distance piping.

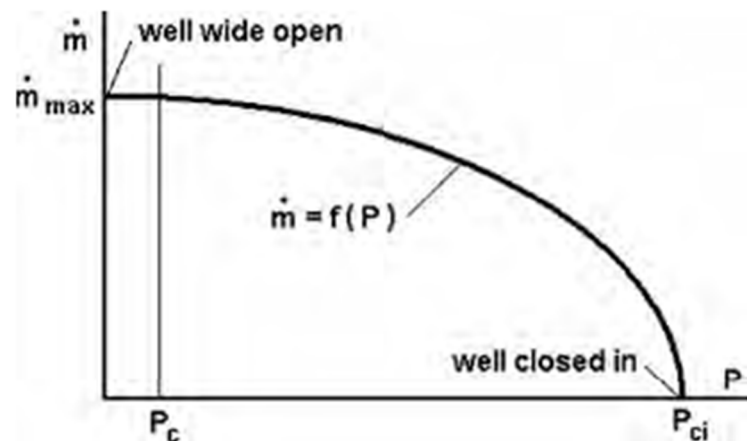

FIGURE 14: Dry steam productivity curve (Dipippo, 2007)

4.4.2 Pressure drop in separators

A separator is a vessel used to separate a mixed-phase stream into gas and liquid phases that are relatively free of each other. They are characterized as either vertical (cyclone) or horizontal (gravity), based on orientation. Recommended inlet velocities should be in the range of 25-40 m/s, the higher the velocity, the better the separation, but it is limited by unacceptable pressure drop. The pressure head is estimated in terms of velocity head as follows (Walas, 1990):

$$\Delta P_{sep} = 4 P \frac{V^2}{2g} \quad (12)$$

where V = Inlet velocity;
 P = Pressure.

For this report, the separators have been installed and so the actual calculations for the pressure drops are not been presented. However, the pressure drop for the high-pressure separators have been taken to be equal to 0.1 bara. The pressure of 0.1 has been assumed to take care of pressure differential between entry and exit.

5. RESULTS AND DISCUSSIONS

The engineering equation solver (EES) was used to calculate the power output of the back pressure turbine and the existing low-pressure turbine for the six cases considered.

Following assumptions have been made to simplify these calculations:

1. The flow of geothermal fluid is steady which means the mass flow in, equals to the mass flow out, and there are no fluid losses;
2. The turbine is thermally insulated which means there is no heat exchange between the turbine and the surrounding environment;
3. Geothermal fluid has the same thermodynamic properties as pure water;
4. The pressure drops have been ignored as the steam field design is already existing and the location of the back pressure turbine is close to the power plant.

5.1 Presentation of the productivity curves

The well tests data presented in this report are for the Olkaria IV geothermal field. They were reviewed and analysed in order to generate productivity curves for the wells to be considered. Table 4 shows discharge test results. A relationship between wellhead pressure (WHP) and the mass flow of the well commonly known as productivity curves is plotted in Figure 15 and a curve is fitted to the test points to correlate the well flow from the corresponding wellhead pressure. Based on the relationship, a correlation polynomial equation of order 3 was developed, represented by Equation 13 (Valdimarsson, 2011)

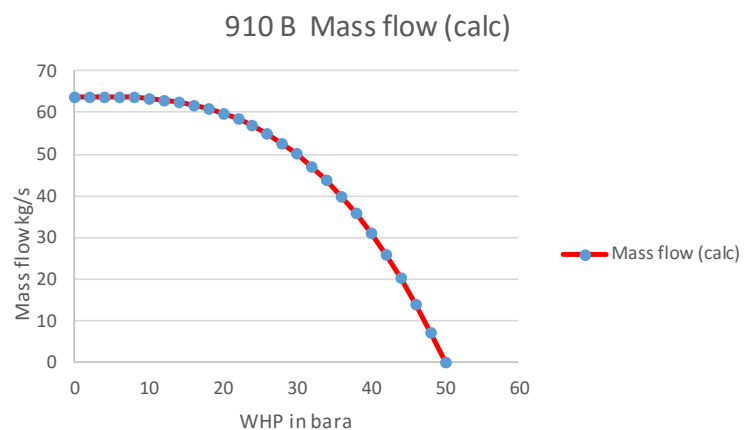

FIGURE 15: Productivity curve for well 910B

$$WHP = a - b * \dot{m}^3 \quad (13)$$

where WHP = wellhead pressure;
 a = closed-in pressure;
 b = ratio of a/\dot{m}^3 when the $WHP=0$.

TABLE 4: Productivity curves parameters

Well	WHP	Productivity curves parameters		Well	WHP	Productivity curves parameters	
		a	b			a	b
W-4	36	36.1	0.0023	W-19	28	27.8	0.0035
W-14	64	63.9	0.0005	W-20	34	33.9	0.0005
W-13	34	33.9	0.0008	W-21	36	35.6	0.0004
W-12	23	22.5	0.0028	W-15	25	25.3	0.0016
W-3	38	37.5	0.0024	W-416	18	18.1	0.0008
W-7	10	10.0	0.0008	W-10	41	40.6	0.0026
W-8	38	38.1	0.0017	W-411	32	32.2	0.0040
W-9	26	25.8	0.0017	W-5	24	23.6	0.0015
W-17	40	40.3	0.0003	W-1	19	19.4	0.0012
W-18	27	26.9	0.0017	W-42	24	23.6	0.0030

5.2 Presentation of wells and steam separation stations

The well data for two separation stations, SD2 and SD3, are presented in Table 5. The steam obtained from these stations is conveyed to each of the steam turbines for power generation. The weighted enthalpy, has been calculated using Equation 14 and mass flow rate is presented in Table 6.

TABLE 5: Mass flow and enthalpy of the wells

Separator station	Well no.	WHP	Two-Ph	Enthalpy	Min h	Max h	Steam	Brine
		bara	t/h	kJ/kg	kJ/kg	kJ/kg	t/h	t/h
SD2A	W-7	14.9	30	2200	2130	2250	21.2	8.8
SD2A	W-8	17.5	115	1420	1380	1470	36.1	78.9
SD2A	W-9	14.7	87	2050	2000	2100	54.9	32.1
SD2C	W-10	12.9	130	2000	1900	2100	78.8	51.2
SD2C	W-11	12.4	100	1820	1700	1870	51.5	48.5
SD2A	W-12	18.3	60	1950	1900	2000	34.8	25.2
SD2B	W-13	18.1	110	2250	2150	2350	80.5	29.5
SD2B	W-14	18.6	210	2000	1700	1900	127.3	82.7
SD3B	W-15	12.6	40	1950	1900	2000	23.2	16.8
SD3B	W-16	12.6	64	2520	2480	2575	55.5	8.5
SD3C	W-17	14.0	130	2475	2425	2550	109.8	20.2
SD3B	W-18	13.4	65	2150	2050	2250	44.3	20.7
SD3A	W-19	16.3	75	2070	1900	2150	48.1	26.9
SD3A	W-20	15.3	110	2450	2375	2525	91.5	18.5
SD3C	W-21	15.4	105	2200	2150	2250	74.1	30.9
	Total		1431				931.7	499.3

$$h_{wg} = \frac{\dot{m}_1 h_1 + \dot{m}_2 h_2}{\dot{m}_1 + \dot{m}_2} \quad (14)$$

where h_{wg} = Weighted enthalpy of two fluids;

- h_1 = Enthalpy of fluid 1;
- h_2 = Enthalpy of fluid 2;
- \dot{m}_1 = Mass flow rate of fluid 1;
- \dot{m}_2 = Mass flow rate of fluid 2.

TABLE 6: Weighted enthalpy and mass flow

Separator stations SD2 and SD3				
	Weighted average	Minimum	Maximum	Units
Enthalpy	2089.9	1980.3	2134.6	kJ/kg
Mass flow	397.5			kg/s

5.3 EES models

Simulation models on EES were made for all the cases considered (see Appendix I for the codes of the selected options). EES results for the current status are shown in Figure 16.

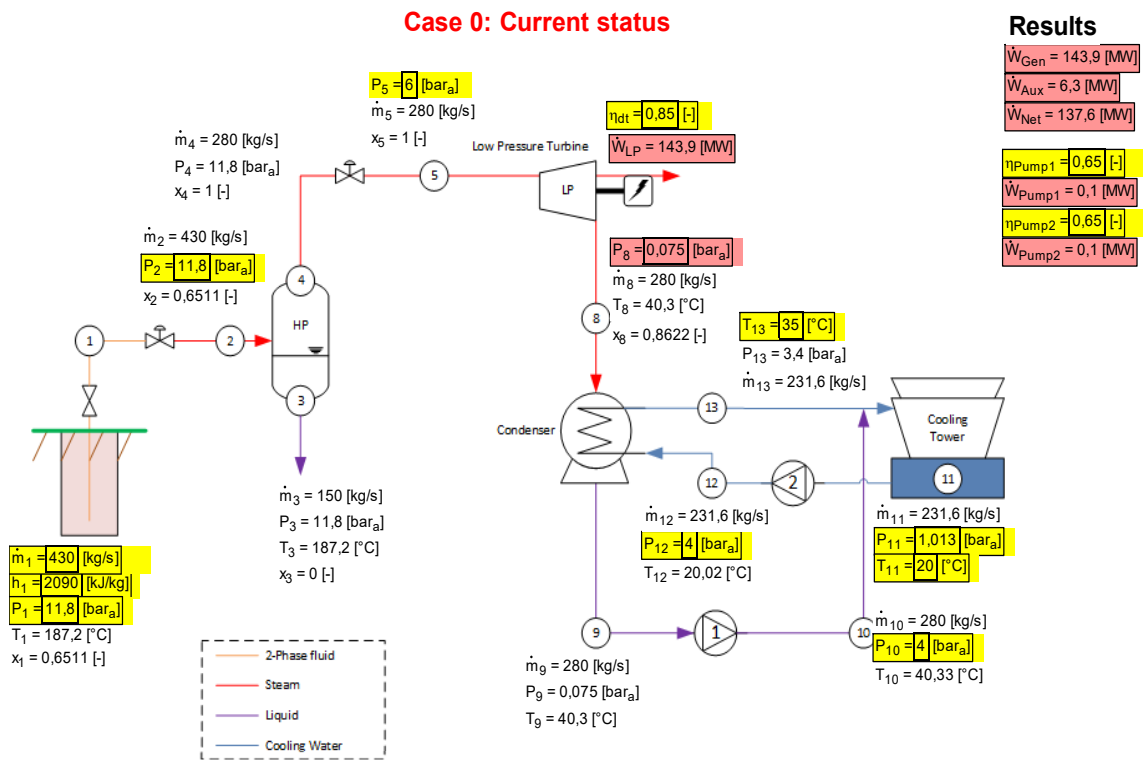

FIGURE 16: EES results for the current status

- where
- \dot{W}_{Gen} = Total power generated;
 - \dot{W}_{HP} = Total power generated by high-pressure turbine;
 - \dot{W}_{LP} = Power generated by low-pressure turbine;
 - \dot{W}_{Net} = Net power generated;
 - \dot{W}_{Aux} = Auxiliary power.

5.3.1 Case 1

All the wells are separated with 11.8 bara separation pressure and the resulting steam passed through the back pressure turbine to reduce the pressure at the existing inlet turbine. A mist eliminator is installed

after the topping unit to remove the condensed steam created during the expansion process of the back pressure turbine.

Two-phase steam from the steam field with a mass flow rate of 430 kg/s and a weighted enthalpy of 2090 kJ/kg is collected and conveyed to the modular separation station at a pressure of 11.8 bara. From the above results, it is noted that for a mass flow rate of 280 kg/s of steam passed through the back pressure turbine at an inlet pressure of 11.8 bara, the electricity equivalent of 29.7 MW would be generated. The quality of exhaust steam is 96%. The condensed steam is then removed by the mist eliminator and the resulting dry steam passed through the main turbine at a pressure of 6 bara. Electricity amounting to 138.5 MW is generated as shown in Figure 17.

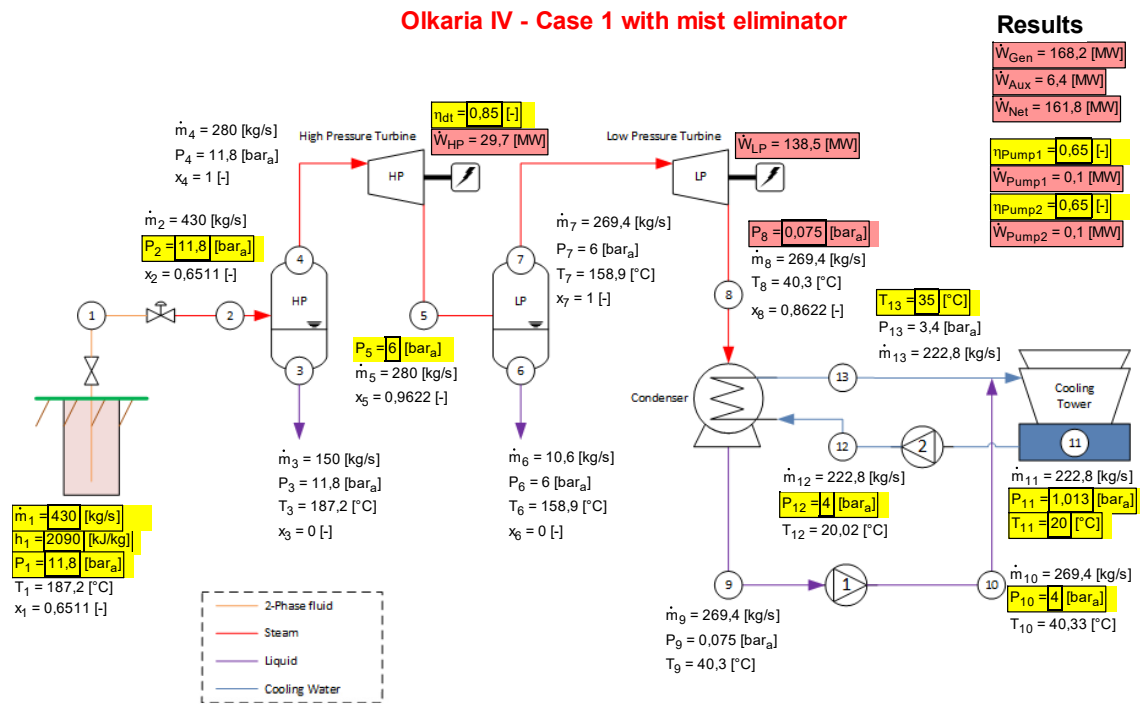

FIGURE 17: EES results of Case 1

5.3.2 Case 2

Two-phase steam from the steam field with a mass flow rate of 430 kg/s and a weighted enthalpy of 2090 kJ/kg is collected and conveyed to the modular separation station at a pressure of 11.8 bara. The brine obtained from the high-pressure separator is then mixed with the exhaust steam at 96% dryness fraction from the back pressure turbine and further flashed at 6 bara. In this case, 29.7 MW of power is obtained from the back pressure turbine and 143.1 MW of power is obtained from the main turbine as shown in Figure 18.

5.3.3 Case 3

Two-phase steam from the steam field with a mass flow rate of 430 kg/s and a weighted enthalpy of 2090 kJ/kg is collected and conveyed to the modular separation station at a pressure of 11.8 bara. The brine obtained from the high-pressure separator is then flashed at a pressure of 6 bara. The steam obtained is then mixed with the exhaust steam from the back pressure turbine. Mist eliminator is installed to remove the condensed water droplets that resulted from the expansion process. The total steam is then conveyed to the main steam turbine at an inlet pressure of 6 bara. In this case, 29.7 MW of power is obtained from the back pressure turbine and 143.1 MW of power is obtained from the main turbine as shown in Figure 19.

Olkaria IV Case 2 - double flash, exhaust steam and brine flashed

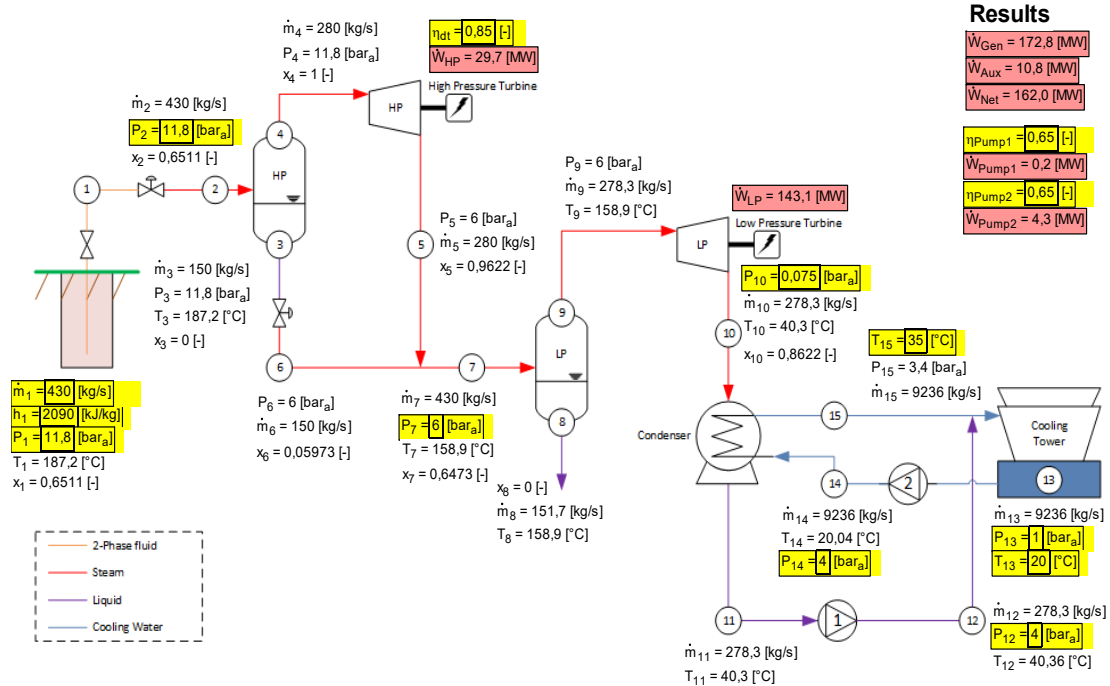

FIGURE 18: EES results of case 2

Olkaria IV Case 3 - double flash, both steam mixed

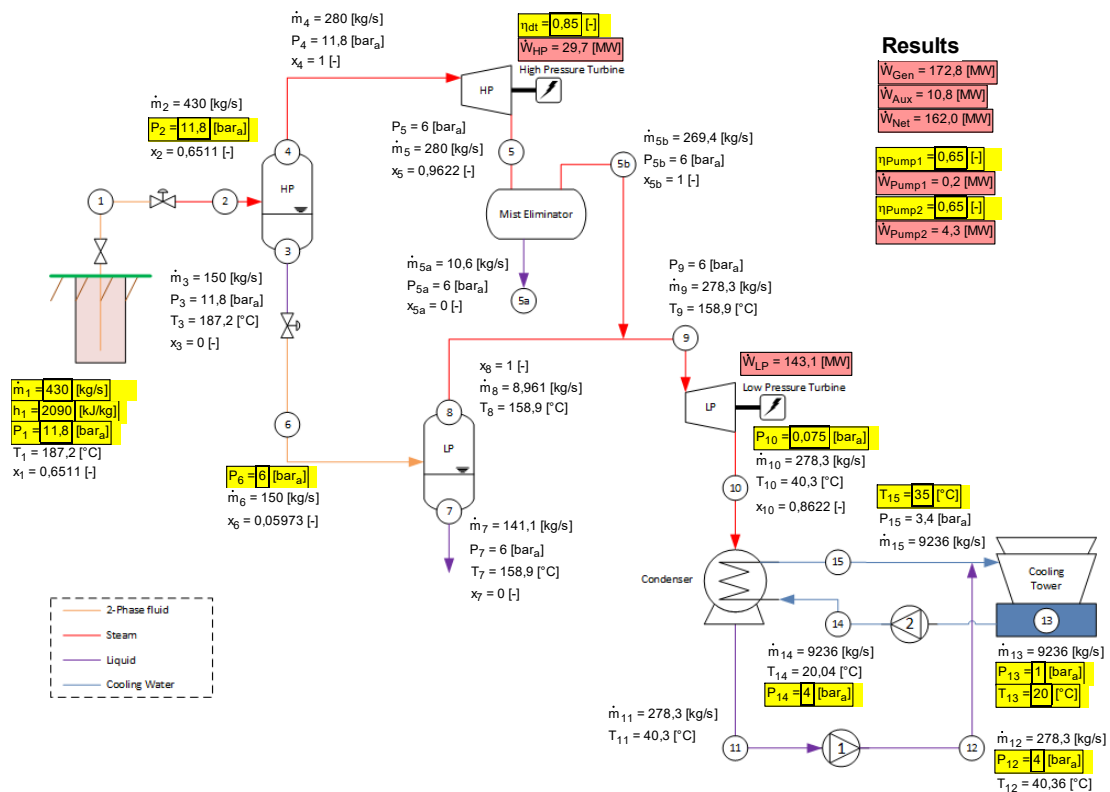

FIGURE 19: EES results of case 3 model

5.3.4 Case 4

Two scenarios were considered here. First, the pressure at the high-pressure separation station is maximized while the pressure at the inlet of the main turbine is fixed at 6 bara. From the results obtained,

the back pressure turbine would generate 16.4 MW of power while the main turbine would generate 150.5 MW of power.

The second scenario is to maximise both the high and low separator pressures. The lower pressure bound pressure would be that of the exhaust pressure of the main turbine. The results obtained for both scenarios are shown in Figure 20 and Figure 21, respectively.

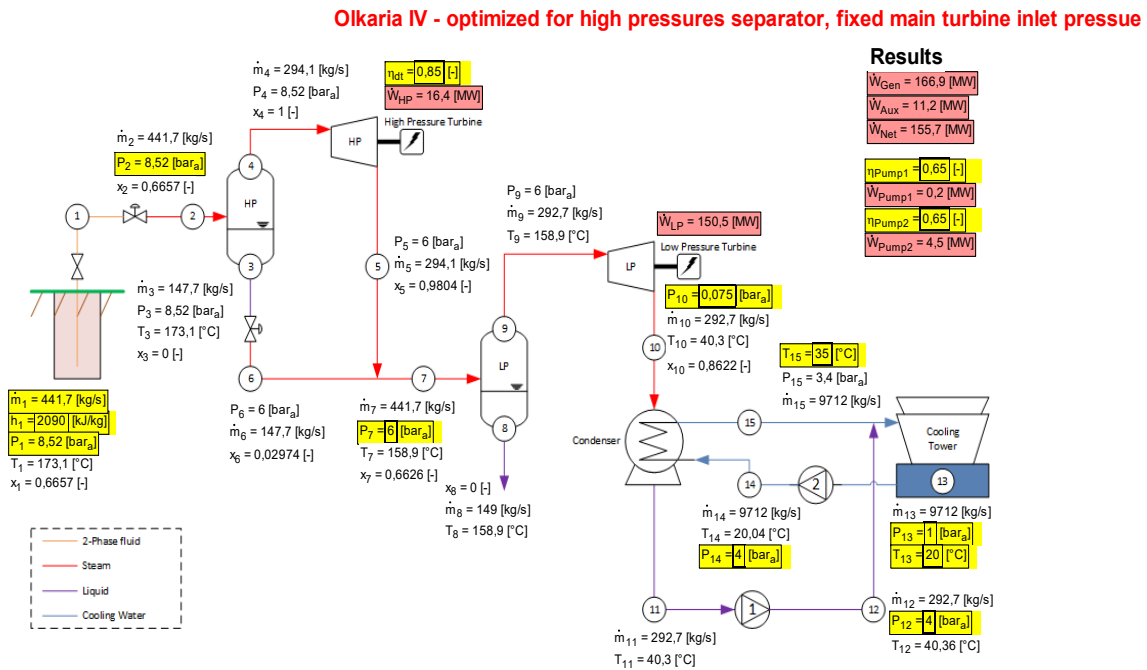

FIGURE 20: EES results of maximized HP separation pressure

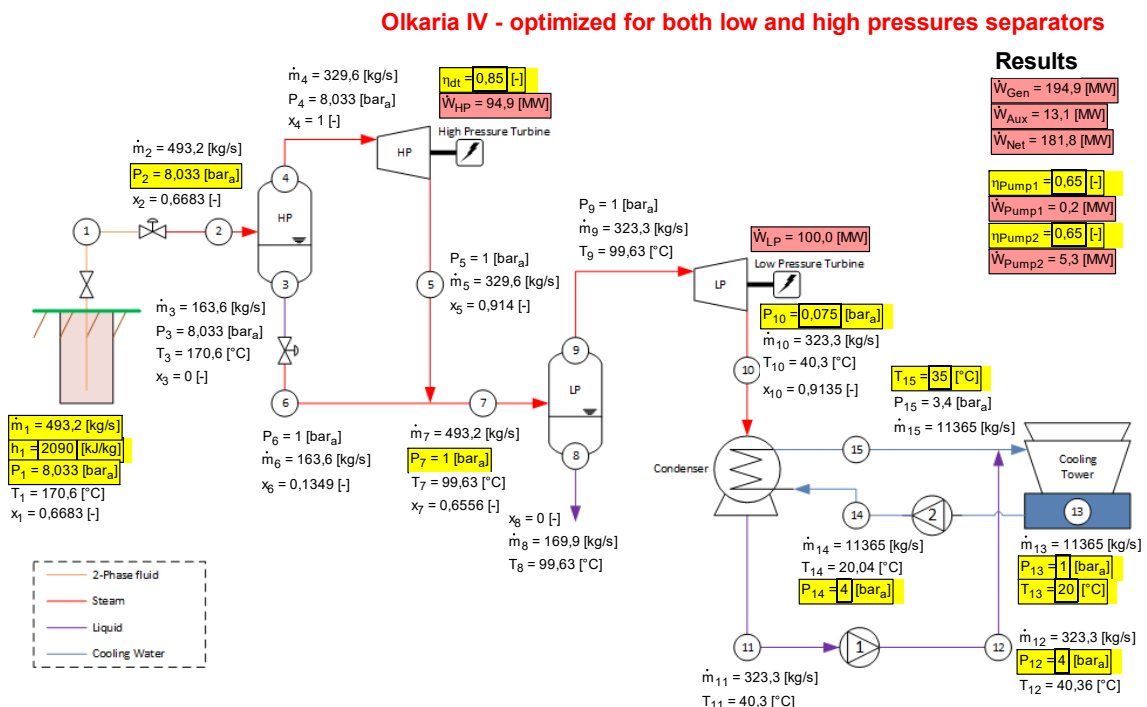

FIGURE 21: EES results of maximized both high and low separation pressure

6. CAPITAL COST OF INSTALLATIONS

From confidential communication with industry participants, it was found that the estimated capital cost of installation of a single flash geothermal power plant with a condensing unit is in the range of USD 3500-4000/kW for smaller units of 5-50 MWe output, and USD 3000-3500/kW for larger units of 50 to 100 MWe. Literature is available on economic comparison between a well-head geothermal power plant and a traditional geothermal power plant (Geirdal, 2013).

These costs include steam field pipelines, steam separators, well connections, civil works, electrical and mechanical installations, switches and controls, generators, evacuation power lines and anything that is needed to make the geothermal power plant operational.

Figures obtained from geothermal developers indicate that the estimated drilling costs for a geothermal well is in the range 4-5 million USD. The average power output of drilled wells in the Olkaria geothermal field, for purposes of this analysis, is assumed to be 6 MWe.

7. CONCLUSIONS AND RECOMMENDATIONS

From the study and the results obtained, the following conclusions and recommendations are made:

1. The total electrical power output that could be generated from the back pressure turbine ranges from 16 to 30 MWe, depending on the option selected, contributing to an increase in gross power of 10 to 20%;
2. It is possible to increase the electrical power by about 5 MW by flashing the brine from the high-pressure separator and adding it back to the main steam line;
3. There is a significant amount of avoided drilling cost, of up to approximately 20 million USD, assuming a conservative cost estimate of 5 million USD per drilled geothermal well;
4. A thorough investigation on the probability of scaling issues in the pipelines during separation should be looked into.

It is recommended to study the economic feasibility of installing a back-pressure turbine, taking into account all the cost of installation and running cost and then compare them with the revenue of selling electricity generated from the back-pressure turbine.

ACKNOWLEDGEMENTS

I would like to express my sincere gratitude to the Government of Iceland, The United Nations University-Geothermal Training Programme (UNU-GTP) and my employer, Kenya Electricity Generating Company, KenGen, for granting me this opportunity to attend this training programme. I owe my sincere appreciation to Mr. Lúdvík S. Georgsson, director of UNU-GTP.

I would also like to thank my supervisors Prof. Páll Valdimarsson and María Sigríður Gudjónsdóttir from Reykjavik University for their guidance, support and advice during my project period. Many thanks to Mr. Ingimar Haraldsson, Mrs. María S Gudjónsdóttir, Mr. Markús A. G. Wilde and Ms. Thórhildur Ísberg for their assistance during my stay in Iceland.

I give special thanks and heartfelt gratitude to my wife Joyce and the entire family for their unwavering support and encouragement throughout the six months and especially for enduring my absence for six months.

I would also like to thank all 2015 UNU-GTP fellows for an unforgettable time during the six months, especially my group in geothermal utilization for all the discussions and the nice times we had together. Finally, I wish to express my heartfelt gratitude to the almighty God for giving me the strength and good health of the entire period.

NOMENCLATURE

C	=	Condenser
CP	=	Condensate pump
CSV	=	Control and stop valves
CT	=	Cooling tower
CWP	=	Cooling water pump
f	=	Saturated liquid
g	=	Saturated vapour
IW	=	Injection well
MR	=	Moisture remover
PW	=	Production well
SE/C	=	Steam ejector/condenser
SP	=	Steam piping
T/G	=	Turbine/generator
S	=	Specific entropy (kJ/kg-K)
T	=	Temperature (°C)
X	=	Quality
W	=	Power (W)

Greek symbols

η	=	Efficiency (%)
ρ	=	density (kg/m ³)

Abbreviations

CS	=	Cooling system
CWP	=	Circulating water pump
EES	=	Engineering Equation Solver
GES	=	Gas extraction system
MWe	=	Megawatt electricity
NCG	=	Non-condensable gases
NCR	=	Nominal continuous rating
SD	=	Separator station
USD	=	United States dollar
WHP	=	Wellhead pressure

REFERENCES

Brookes, B, Chong, W and De Krester, S. 2011: Olkaria geothermal project: Fast-track geothermal steamfield development using modular steam separator stations. *Proceedings, Kenya Geothermal Conference 2011, Kenyatta International Conference Centre, Nairobi, November 21-22*, 6 pp.

DiPippo, R., 2007: *Geothermal power plants. Principles, applications, case studies and environmental impact* (2nd ed.). Butterworth Heineman, Elsevier, Kidlington, UK, 493 pp.

Geirdal, C.A.C., 2013: *Economic Comparison between a Wellhead Geothermal Power Plant and a Traditional Geothermal Power Plant*. Reykjavík University, Reykjavík, Iceland, MSc thesis, 100 pp.

Kaplan. U. and Schochet. D.N., 2000: Improving geothermal power plant performance with topping and bottoming cycles. Case histories in Iceland, New Zealand, and the Philippines. *Proceedings World Geothermal Congress 2000, Kyushu-Tohoku, Japan*, 2111-2114.

Karingithi, C., 2002: *Hydrothermal mineral buffers controlling reactive gases concentration in the Greater Olkaria geothermal system, Kenya*. University of Iceland, MSc thesis, UNU-GTP, Iceland report 2, 51 pp.

KenGen, 2011: *Olkaria IV 280 MW Geothermal power plant contract document*. KenGen, unpublished internal execution contract document.

KenGen, 2012: *Wells data summary, Olkaria IV Domes*. KenGen, unpublished internal well testing report.

Lagat, J.K., 2004: *Geology, hydrothermal alteration and fluid inclusion studies of the Olkaria Domes geothermal field, Kenya*. University of Iceland, MSc thesis, UNU-GTP, Iceland, report 2, 71 pp.

Lee, K.C., 1996: *Classification of geothermal resources: An engineering approach*. Proceedings of the 21st Workshop on Geothermal Reservoir Engineering, Stanford University, Stanford, Ca, 85-92.

Thain, I.A. and Carey, B., 2008: Fifty years of geothermal power generation at Wairakei. *Geothermics* 38, 48–63.

Thome, J. (ed.), 2006: *Engineering data*. Book III. Wolverine Tube Inc., Lausanne, Switzerland.

Valdimarsson, P., 2011: Geothermal power plant cycles and main components. *Presented at "Short Course on Geothermal Drilling. Resource Development and Power Plants", organized by UNU-GTP and LaGeo, in Santa Tecla. El Salvador*, 24 pp.

Walas, S.M., 1990: *Chemical process equipment, selection and design*. Butterworth-Heinemann, Washington, USA, 755 pp.

APPENDIX I: EES codes for cases selected

EES CODES

Case 0: Current status

"Wells"

T[1]=Temperature(Water;P=P[1];h=h[1])
x[1]=Quality(Water;h=h[1];P=P[1])

"State 2"

h[2]=h[1]
m_dot[2]=m_dot[1]
x[2]=Quality(Water;h=h[2];P=P[2])

"State 3"

P[3]=P[2]
x[3]=0 [-]
h[3]=enthalpy(Water;P=P[3];X=x[3])
T[3]=Temperature(Water;P=P[3];x=x[3])
v[3]=volume(Water;h=h[3];P=P[3])
m_dot[3]=(1-x[2])*m_dot[2]

"State 4"

$P[4]=P[2]$
 $x[4]=1$ [-]
 $h[4]=\text{enthalpy}(\text{Water};P=P[4];X=x[4])$
 $T[4]=\text{Temperature}(\text{Water};P=P[4];x=x[4])$
 $s[4]=\text{entropy}(\text{Water};P=P[4];x=x[4])$
 $m_dot[4]=x[2]*m_dot[2]$

"State 5"

$h[5]=\text{enthalpy}(\text{Water};P=P[5];x=1)$
 $s[5]=\text{entropy}(\text{Water};P=P[5];x=1)$
 $T[5]=\text{Temperature}(\text{Water};P=P[5];x=1)$
 $x[5]=1$
 $m_dot[5]=m_dot[4]$

"State 8"

$s_8s=s[5]$
 $h_8s=\text{enthalpy}(\text{Water};P=P[8];s=s_8s)$
"Baumann rule"
 $h_aLP=\text{enthalpy}(\text{Water};P=P[8];x=0)$
 $h_bLP=\text{enthalpy}(\text{Water};P=P[8];x=1)$
 $A_LP=\eta_{dt}/2*(h[5]-h_8s)$
 $h[8]=(h[5]-A_LP*(1-h_aLP/(h_bLP-h_aLP)))/(1+A_LP/(h_bLP-h_aLP))$
 $s[8]=\text{entropy}(\text{Water};P=P[8];h=h[8])$
 $x[8]=\text{Quality}(\text{Water};h=h[8];P=P[8])$
 $T[8]=\text{Temperature}(\text{Water};P=P[8];h=h[8])$
 $m_dot[8]=m_dot[5]$

"State 9"

$P[9] = P[8]$
 $x[9] = 0$
 $h[9] = \text{enthalpy}(\text{Water};P=P[9];x=x[9])$
 $T[9] = \text{Temperature}(\text{Water};P=P[9];x=x[9])$
 $v[9] = \text{volume}(\text{Water};P=P[9];x=x[9])$
 $m_dot[9] = m_dot[8]$

"State 10"

$m_dot[10]=m_dot[9]$
 $h_10s=h[9]+v[9]*(P[10]-P[9])*80$
 $h[10]=h[9]+(h_10s-h[9])/eta_Pump1$
 $T[10]=\text{Temperature}(\text{Water};P=P[10];h=h[10])$
 $x[10]=\text{quality}(\text{Water};P=P[10];h=h[10])$
 $v[10]=\text{Volume}(\text{Water};P=P[10];h=h[10])$

"State 11"

$m_dot[11] = Q_dot_Condenser*800/(h[2]-h[12])$
 $h[11]=\text{enthalpy}(\text{Water};T=T[11];P=P[11])$
 $v[11]=\text{volume}(\text{Water};T=T[11];P=P[11])$

"State 12"

$m_dot[12]=m_dot[11]$
 $h_12s=h[11]+v[11]*(P[12]-P[11])*80$
 $h[12]=h[11]+(h_12s-h[11])/eta_Pump2$
 $T[12]=\text{Temperature}(\text{Water};P=P[12];h=h[12])$
 $x[12]=\text{quality}(\text{Water};P=P[12];h=h[12])$

"State 13"

$DELTA P_Condenser=0,6$ [bar]
 $P[13]=P[12]-DELTA P_Condenser$
 $h[13]=\text{enthalpy}(\text{Water};T=T[13];P=P[13])$
 $m_dot[13]=m_dot[12]$

"Energy calculations"

$W_dot_LP = m_dot[5]*(h[5]-h[8])/1000$
 $W_dot_Pump1 = m_dot[9]*(h[10]-h[9])/1000$
 $W_dot_Pump2 = m_dot[11]*(h[12]-h[11])/1000$
 $W_dot_Pumps = W_dot_Pump1+W_dot_Pump2$
 $W_dot_Gen = W_dot_LP$
 $W_dot_Aux = W_dot_Pumps+W_dot_400V+W_dot_CoolingTower+W_dot_GasExtraction+W_dot_T\&G+W_dot_Other$

$$W_{\text{dot_Net}} = W_{\text{dot_Gen}} - W_{\text{dot_Aux}}$$

"Auxiliaries power consumption"

$$W_{\text{dot_400V}} = 3,89 * W_{\text{dot_Gen}} / 1000$$

$$W_{\text{dot_T\&G}} = 2,3 * W_{\text{dot_Gen}} / 1000$$

$$W_{\text{dot_CoolingTower}} = 4,13 * Q_{\text{dot_Condenser}} / 1000$$

$$W_{\text{dot_GasExtraction}} = 4,13 * Q_{\text{dot_Condenser}} / 1000$$

$$W_{\text{dot_Other}} = 3,04 * W_{\text{dot_Gen}} / 1000$$

"Cooling capacity of Condenser"

$$Q_{\text{dot_Condenser}} = m_{\text{dot}} \{8\} * (h\{8\} - h\{9\}) / 1000$$

Case 1: Topping unit with mist eliminator

"Wells"

$$T\{1\} = \text{Temperature}(\text{Water}; P=P\{1\}; h=h\{1\})$$

$$x\{1\} = \text{Quality}(\text{Water}; h=h\{1\}; P=P\{1\})$$

"State 2"

$$h\{2\} = h\{1\}$$

$$m_{\text{dot}}\{2\} = m_{\text{dot}}\{1\}$$

$$x\{2\} = \text{Quality}(\text{Water}; h=h\{2\}; P=P\{2\})$$

"State 3"

$$P\{3\} = P\{2\}$$

$$x\{3\} = 0 \text{ [-]}$$

$$h\{3\} = \text{enthalpy}(\text{Water}; P=P\{3\}; X=x\{3\})$$

$$T\{3\} = \text{Temperature}(\text{Water}; P=P\{3\}; x=x\{3\})$$

$$v\{3\} = \text{volume}(\text{Water}; h=h\{3\}; P=P\{3\})$$

$$m_{\text{dot}}\{3\} = (1 - x\{2\}) * m_{\text{dot}}\{2\}$$

"State 4"

$$P\{4\} = P\{2\}$$

$$x\{4\} = 1 \text{ [-]}$$

$$h\{4\} = \text{enthalpy}(\text{Water}; P=P\{4\}; X=x\{4\})$$

$$T\{4\} = \text{Temperature}(\text{Water}; P=P\{4\}; x=x\{4\})$$

$$s\{4\} = \text{entropy}(\text{Water}; P=P\{4\}; x=x\{4\})$$

$$m_{\text{dot}}\{4\} = x\{2\} * m_{\text{dot}}\{2\}$$

"State 5"

$$s_{\text{5s}} = s\{4\}$$

$$h_{\text{5s}} = \text{enthalpy}(\text{Water}; P=P\{5\}; s=s_{\text{5s}})$$

"Baumann rule"

$$h_{\text{a}} = \text{enthalpy}(\text{Water}; P=P\{5\}; x=0)$$

$$h_{\text{b}} = \text{enthalpy}(\text{Water}; P=P\{5\}; x=1)$$

$$A = \frac{\eta_{\text{dt}}}{2} * (h\{4\} - h_{\text{5s}})$$

$$h\{5\} = (h\{4\} - A * (1 - h_{\text{a}} / (h_{\text{b}} - h_{\text{a}}))) / (1 + A / (h_{\text{b}} - h_{\text{a}}))$$

$$s\{5\} = \text{entropy}(\text{Water}; P=P\{5\}; h=h\{5\})$$

$$x\{5\} = \text{Quality}(\text{Water}; h=h\{5\}; P=P\{5\})$$

$$T\{5\} = \text{Temperature}(\text{Water}; P=P\{5\}; h=h\{5\})$$

$$m_{\text{dot}}\{5\} = m_{\text{dot}}\{4\}$$

"State 6"

$$P\{6\} = P\{5\}$$

$$x\{6\} = 0 \text{ [-]}$$

$$h\{6\} = \text{enthalpy}(\text{Water}; P=P\{6\}; X=x\{6\})$$

$$T\{6\} = \text{Temperature}(\text{Water}; P=P\{6\}; x=x\{6\})$$

$$v\{6\} = \text{volume}(\text{Water}; h=h\{6\}; P=P\{6\})$$

$$m_{\text{dot}}\{6\} = (1 - x\{5\}) * m_{\text{dot}}\{5\}$$

"State 7"

$$P\{7\} = P\{6\}$$

$$x\{7\} = 1 \text{ [-]}$$

$$h\{7\} = \text{enthalpy}(\text{Water}; P=P\{7\}; X=x\{7\})$$

$$T\{7\} = \text{Temperature}(\text{Water}; P=P\{7\}; x=x\{7\})$$

$$s\{7\} = \text{entropy}(\text{Water}; P=P\{7\}; x=x\{7\})$$

$$m_{\text{dot}}\{7\} = x\{5\} * m_{\text{dot}}\{5\}$$

"State 8"

$$s_{\text{8s}} = s\{7\}$$

```

h_8s=enthalpy(Water;P=P[8];s=s_8s)
"!Baumann rule"
h_aLP=enthalpy(Water;P=P[8];x=0)
h_bLP=enthalpy(Water;P=P[8];x=1)
A_LP=eta_dt/2*(h[7]-h_8s)
h[8]=(h[7]-A_LP*(1-h_aLP/(h_bLP-h_aLP)))/(1+A_LP/(h_bLP-h_aLP))
s[8]=entropy(Water;P=P[8];h=h[8])
x[8]=Quality(Water;h=h[8];P=P[8])
T[8]=Temperature(Water;P=P[8];h=h[8])
m_dot[8]=m_dot[7]

```

"State 9"

```

P[9] = P[8]
x[9] = 0
h[9] = enthalpy(Water;P=P[9];x=x[9])
T[9] = Temperature(Water;P=P[9];x=x[9])
v[9] = volume(Water;P=P[9];x=x[9])
m_dot[9] = m_dot[8]

```

"State 10"

```

m_dot[10]=m_dot[9]
h_10s=h[9]+v[9]*(P[10]-P[9])*80
h[10]=h[9]+(h_10s-h[9])/eta_Pump1
T[10]=Temperature(Water;P=P[10];h=h[10])
x[10]=quality(Water;P=P[10];h=h[10])
v[10]=Volume(Water;P=P[10];h=h[10])

```

"State 11"

```

m_dot[11] = Q_dot_Condenser*800/(h[2]-h[12])
h[11]=enthalpy(Water;T=T[11];P=P[11])
v[11]=volume(Water;T=T[11];P=P[11])

```

"State 12"

```

m_dot[12]=m_dot[11]
h_12s=h[11]+v[11]*(P[12]-P[11])*80
h[12]=h[11]+(h_12s-h[11])/eta_Pump2
T[12]=Temperature(Water;P=P[12];h=h[12])
x[12]=quality(Water;P=P[12];h=h[12])

```

"State 13"

```

DELTA_P_Condenser=0,6 [bar]
P[13]=P[12]-DELTA_P_Condenser
h[13]=enthalpy(Water;T=T[13];P=P[13])
m_dot[13]=m_dot[12]

```

"Energy calculations"

```

W_dot_HP = m_dot[4]*(h[4]-h[5])/1000
W_dot_LP = m_dot[7]*(h[7]-h[8])/1000
W_dot_Pump1 = m_dot[9]*(h[10]-h[9])/1000
W_dot_Pump2 = m_dot[11]*(h[12]-h[11])/1000
W_dot_Pumps = W_dot_Pump1+W_dot_Pump2
W_dot_Gen = W_dot_HP+W_dot_LP
W_dot_Aux = W_dot_Pumps+W_dot_400V+W_dot_CoolingTower+W_dot_GasExtraction+W_dot_T&G+W_dot_Other
W_dot_Net=W_dot_Gen-W_dot_Aux

```

"Auxiliary power consumption"

```

W_dot_400V=3,89*W_dot_Gen/1000
W_dot_T&G=2,3*W_dot_Gen/1000
W_dot_CoolingTower = 4,13*Q_dot_Condenser/1000
W_dot_GasExtraction=4,13*Q_dot_Condenser/1000
W_dot_Other=3,04*W_dot_Gen/1000

```

"Cooling capacity of Condenser"

```

Q_dot_Condenser = m_dot[8]*(h[8]-h[9])/1000

```

Case 2: Topping unit with double flash

"Wells"

```

T[1]=Temperature(Water;P=P[1];h=h[1])
x[1]=Quality(Water;h=h[1];P=P[1])

```

"State 2"

$h[2]=h[1]$
 $m_dot[2]=m_dot[1]$
 $x[2]=Quality(Water;h=h[2];P=P[2])$

"State 3"

$P[3]=P[2]$
 $x[3]=0$ [-]
 $h[3]=enthalpy(Water;P=P[3];X=x[3])$
 $T[3]=Temperature(Water;P=P[3];x=x[3])$
 $v[3]=volume(Water;h=h[3];P=P[3])$
 $m_dot[3]=(1-x[2])*m_dot[2]$

"State 4"

$P[4]=P[2]$
 $x[4]=1$ [-]
 $h[4]=enthalpy(Water;P=P[4];X=x[4])$
 $T[4]=Temperature(Water;P=P[4];x=x[4])$
 $s[4]=entropy(Water;P=P[4];x=x[4])$
 $m_dot[4]=x[2]*m_dot[2]$

"State 5"

$P[5] = P[7]$
 $s_5s=s[4]$
 $h_5s=enthalpy(Water;P=P[5];s=s_5s)$
"!Baumann rule"
 $h_a=enthalpy(Water;P=P[5];x=0)$
 $h_b=enthalpy(Water;P=P[5];x=1)$
 $A=eta_dt/2*(h[4]-h_5s)$
 $h[5]=(h[4]-A*(1-h_a/(h_b-h_a)))/(1+A/(h_b-h_a))$
 $s[5]=entropy(Water;P=P[5];h=h[5])$
 $x[5]=Quality(Water;h=h[5];P=P[5])$
 $T[5]=Temperature(Water;P=P[5];h=h[5])$
 $m_dot[5]=m_dot[4]$

"State 6"

$P[6] = P[7]$
 $h[6] = h[3]$
 $m_dot[6]=m_dot[3]$
 $x[6]=Quality(Water;h=h[6];P=P[6])$

"State 7"

$m_dot[7] = m_dot[5] + m_dot[6]$
 $h[7] = (h[5]*m_dot[5] + h[6]*m_dot[6])/m_dot[7]$
 $T[7]=Temperature(Water;P=P[7];h=h[7])$
 $x[7]=quality(Water;P=P[7];h=h[7])$
 $v[7]=Volume(Water;P=P[7];h=h[7])$

"State 8"

$P[8] = P[7]$
 $x[8]=0$ [-]
 $h[8]=enthalpy(Water;P=P[8];X=x[8])$
 $T[8]=Temperature(Water;P=P[8];x=x[8])$
 $v[8]=volume(Water;h=h[8];P=P[8])$
 $m_dot[8]=(1-x[7])*m_dot[7]$

"State 9"

$P[9]=P[7]$
 $x[9]=1$ [-]
 $h[9]=enthalpy(Water;P=P[9];X=x[9])$
 $T[9]=Temperature(Water;P=P[9];x=x[9])$
 $s[9] = entropy(Water;P=P[9];x=x[9])$
 $m_dot[9]=x[7]*m_dot[7]$

"State 10"

$s_10s=s[9]$
 $h_10s=enthalpy(Water;P=P[10];s=s_10s)$
"!Baumann rule"
 $h_aLP=enthalpy(Water;P=P[10];x=0)$
 $h_bLP=enthalpy(Water;P=P[10];x=1)$

$A_{LP} = \eta_{dt} / 2 * (h[9] - h_{10s})$
 $h[10] = (h[9] - A_{LP} * (1 - h_{aLP} / (h_{bLP} - h_{aLP}))) / (1 + A_{LP} / (h_{bLP} - h_{aLP}))$
 $s[10] = \text{entropy}(\text{Water}; P=P[10]; h=h[10])$
 $x[10] = \text{Quality}(\text{Water}; h=h[10]; P=P[10])$
 $T[10] = \text{Temperature}(\text{Water}; P=P[10]; h=h[10])$
 $m_{dot}[10] = m_{dot}[9]$

"State 11"

$P[11] = P[10]$
 $x[11] = 0$
 $h[11] = \text{enthalpy}(\text{Water}; P=P[11]; x=x[11])$
 $T[11] = \text{Temperature}(\text{Water}; P=P[11]; x=x[11])$
 $v[11] = \text{volume}(\text{Water}; P=P[11]; x=x[11])$
 $m_{dot}[11] = m_{dot}[10]$

"State 12"

$m_{dot}[12] = m_{dot}[11]$
 $h_{12s} = h[11] + v[11] * (P[12] - P[11]) * 100$
 $h[12] = h[11] + (h_{12s} - h[11]) / \eta_{Pump1}$
 $T[12] = \text{Temperature}(\text{Water}; P=P[12]; h=h[12])$
 $x[12] = \text{quality}(\text{Water}; P=P[12]; h=h[12])$
 $v[12] = \text{Volume}(\text{Water}; P=P[12]; h=h[12])$

"State 13"

$m_{dot}[13] = Q_{dot_Condenser} * 1000 / (h[15] - h[14])$
 $h[13] = \text{enthalpy}(\text{Water}; T=T[13]; P=P[13])$
 $v[13] = \text{volume}(\text{Water}; T=T[13]; P=P[13])$

"State 14"

$m_{dot}[14] = m_{dot}[13]$
 $h_{14s} = h[13] + v[13] * (P[14] - P[13]) * 100$
 $h[14] = h[13] + (h_{14s} - h[13]) / \eta_{Pump2}$
 $T[14] = \text{Temperature}(\text{Water}; P=P[14]; h=h[14])$
 $x[14] = \text{quality}(\text{Water}; P=P[14]; h=h[14])$

"State 15"

$\Delta P_{Condenser} = 0,6 \text{ [bar]}$
 $P[15] = P[14] - \Delta P_{Condenser}$
 $h[15] = \text{enthalpy}(\text{Water}; T=T[15]; P=P[15])$
 $m_{dot}[15] = m_{dot}[14]$

"!Energy calculations"

$W_{dot_HP} = m_{dot}[4] * (h[4] - h[5]) / 1000$
 $W_{dot_LP} = m_{dot}[9] * (h[9] - h[10]) / 1000$
 $W_{dot_Pump1} = m_{dot}[11] * (h[12] - h[11]) / 1000$
 $W_{dot_Pump2} = m_{dot}[13] * (h[14] - h[13]) / 1000$
 $W_{dot_Pumps} = W_{dot_Pump1} + W_{dot_Pump2}$
 $W_{dot_Gen} = W_{dot_HP} + W_{dot_LP}$
 $W_{dot_Aux} = W_{dot_Pumps} + W_{dot_400V} + W_{dot_CoolingTower} + W_{dot_GasExtraction} + W_{dot_T\&G} + W_{dot_Other}$
 $W_{dot_Net} = W_{dot_Gen} - W_{dot_Aux}$

"Auxiliary power consumption"

$W_{dot_400V} = 3,89 * W_{dot_Gen} / 1000$
 $W_{dot_T\&G} = 2,3 * W_{dot_Gen} / 1000$
 $W_{dot_CoolingTower} = 4,13 * Q_{dot_Condenser} / 1000$
 $W_{dot_GasExtraction} = 4,13 * Q_{dot_Condenser} / 1000$
 $W_{dot_Other} = 3,04 * W_{dot_Gen} / 1000$

"Cooling capacity of Condenser"

$Q_{dot_Condenser} = m_{dot}[10] * (h[10] - h[11]) / 1000$

Case 3: Topping unit, double flash, both steam mixed**"Wells"**

$P_{1_barg} = P[1] - 1,01325$
 $T[1] = \text{Temperature}(\text{Water}; P=P[1]; h=h[1])$
 $x[1] = \text{Quality}(\text{Water}; h=h[1]; P=P[1])$

"State 2"

$h[2]=h[1]$
 $m_dot[2]=m_dot[1]$
 $x[2]=Quality(Water;h=h[2];P=P[2])$

"State 3"

$P[3]=P[2]$
 $x[3]=0$ [-]
 $h[3]=enthalpy(Water;P=P[3];X=x[3])$
 $T[3]=Temperature(Water;P=P[3];x=x[3])$
 $v[3]=volume(Water;h=h[3];P=P[3])$
 $m_dot[3]=(1-x[2])*m_dot[2]$

"State 4"

$P[4]=P[2]$
 $x[4]=1$ [-]
 $h[4]=enthalpy(Water;P=P[4];X=x[4])$
 $T[4]=Temperature(Water;P=P[4];x=x[4])$
 $s[4]=entropy(Water;P=P[4];x=x[4])$
 $m_dot[4]=x[2]*m_dot[2]$

"State 5"

$P[5] = P[6]$
 $s_5s=s[4]$
 $h_5s=enthalpy(Water;P=P[5];s=s_5s)$
"!Baumann rule"
 $h_a=enthalpy(Water;P=P[5];x=0)$
 $h_b=enthalpy(Water;P=P[5];x=1)$
 $A=eta_dt/2*(h[4]-h_5s)$
 $h[5]=(h[4]-A*(1-h_a/(h_b-h_a)))/(1+A/(h_b-h_a))$
 $s[5]=entropy(Water;P=P[5];h=h[5])$
 $x[5]=Quality(Water;h=h[5];P=P[5])$
 $T[5]=Temperature(Water;P=P[5];h=h[5])$
 $m_dot[5]=m_dot[4]$

"State 5a"

$P_5a=P[5]$
 $x_5a=0$ [-]
 $h_5a=enthalpy(Water;P=P_5a;X=x_5a)$
 $T_5a=Temperature(Water;P=P_5a;x=x_5a)$
 $v_5a=volume(Water;h=h_5a;P=P_5a)$
 $m_dot_5a=(1-x[5])*m_dot[5]$

"State 5b"

$P_5b=P[5]$
 $x_5b=1$ [-]
 $h_5b=enthalpy(Water;P=P_5b;X=x_5b)$
 $T_5b=Temperature(Water;P=P_5b;x=x_5b)$
 $s_5b=entropy(Water;P=P_5b;x=x_5b)$
 $m_dot_5b=x[5]*m_dot[5]$

"State 6"

$h[6] = h[3]$
 $m_dot[6]=m_dot[3]$
 $x[6]=Quality(Water;h=h[6];P=P[6])$

"State 7"

$P[7]=P[6]$
 $x[7]=0$ [-]
 $h[7]=enthalpy(Water;P=P[7];X=x[7])$
 $T[7]=Temperature(Water;P=P[7];x=x[7])$
 $v[7]=volume(Water;h=h[7];P=P[7])$
 $m_dot[7]=(1-x[6])*m_dot[6]$

"State 8"

$P[8]=P[6]$
 $x[8]=1$ [-]
 $h[8]=enthalpy(Water;P=P[8];X=x[8])$
 $T[8]=Temperature(Water;P=P[8];x=x[8])$
 $m_dot[8]=x[6]*m_dot[6]$

"State 9"

```

m_dot[9] = m_dot_5b + m_dot[8]
P[9] = P[6]
h[9] = (h_5b*m_dot_5b + h[8]*m_dot[8])/m_dot[9]
T[9]=Temperature(Water;P=P[9];h=h[9])
x[9]=quality(Water;P=P[9];h=h[9])
v[9]=Volume(Water;P=P[9];h=h[9])
s[9] = entropy(Water;P=P[9];h=h[9])

```

"State 10"

```

s_10s=s[9]
h_10s=enthalpy(Water;P=P[10];s=s_10s)
"!Baumann rule"
h_aLP=enthalpy(Water;P=P[10];x=0)
h_bLP=enthalpy(Water;P=P[10];x=1)
A_LP=eta_dt/2*(h[9]-h_10s)
h[10]=(h[9]-A_LP*(1-h_aLP/(h_bLP-h_aLP)))/(1+A_LP/(h_bLP-h_aLP))
s[10]=entropy(Water;P=P[10];h=h[10])
x[10]=Quality(Water;h=h[10];P=P[10])
T[10]=Temperature(Water;P=P[10];h=h[10])
m_dot[10]=m_dot[9]

```

"State 11"

```

P[11] = P[10]
x[11] = 0
h[11] = enthalpy(Water;P=P[11];x=x[11])
T[11] = Temperature(Water;P=P[11];x=x[11])
v[11] = volume(Water;P=P[11];x=x[11])
m_dot[11] = m_dot[10]

```

"State 12"

```

m_dot[12]=m_dot[11]
h_12s=h[11]+v[11]*(P[12]-P[11])*100
h[12]=h[11]+(h_12s-h[11])/eta_Pump1
T[12]=Temperature(Water;P=P[12];h=h[12])
x[12]=quality(Water;P=P[12];h=h[12])
v[12]=Volume(Water;P=P[12];h=h[12])

```

"State 13"

```

m_dot[13] = Q_dot_Condenser*1000/(h[15]-h[14])
h[13]=enthalpy(Water;T=T[13];P=P[13])
v[13]=volume(Water;T=T[13];P=P[13])

```

"State 14"

```

m_dot[14]=m_dot[13]
h_14s=h[13]+v[13]*(P[14]-P[13])*100
h[14]=h[13]+(h_14s-h[13])/eta_Pump2
T[14]=Temperature(Water;P=P[14];h=h[14])
x[14]=quality(Water;P=P[14];h=h[14])

```

"State 15"

```

DELTA_P_Condenser=0,6 [bar]
P[15]=P[14]-DELTA_P_Condenser
h[15]=enthalpy(Water;T=T[15];P=P[15])
m_dot[15]=m_dot[14]

```

"!Auxiliaries"**"Energy calculations"**

```

W_dot_HP = m_dot[4]*(h[4]-h[5])/1000
W_dot_LP = m_dot[9]*(h[9]-h[10])/1000
W_dot_Pump1 = m_dot[11]*(h[12]-h[11])/1000
W_dot_Pump2 = m_dot[13]*(h[14]-h[13])/1000
W_dot_Pumps = W_dot_Pump1+W_dot_Pump2
W_dot_Gen = W_dot_HP+W_dot_LP
W_dot_Aux = W_dot_Pumps+W_dot_400V+W_dot_CoolingTower+W_dot_GasExtraction+W_dot_T&G+W_dot_Other
W_dot_Net=W_dot_Gen-W_dot_Aux

```

"Auxiliary power consumption"

```

W_dot_400V=3,89*W_dot_Gen/1000
W_dot_T&G=2,3*W_dot_Gen/1000

```

$W_{\text{dot_CoolingTower}} = 4,13 \cdot Q_{\text{dot_Condenser}} / 1000$
 $W_{\text{dot_GasExtraction}} = 4,13 \cdot Q_{\text{dot_Condenser}} / 1000$
 $W_{\text{dot_Other}} = 3,04 \cdot W_{\text{dot_Gen}} / 1000$

"Cooling capacity of Condenser"

$Q_{\text{dot_Condenser}} = m_{\text{dot}}[10] \cdot (h[10] - h[11]) / 1000$

Case 4a: Topping unit, optimized, fixed pressure for main turbine

"Wells"

$m1 = 38 - 0,0017 \cdot P[1]^3$ {OW 908A}
 $m2 = 25,8 - 0,0017 \cdot P[1]^3$ {OW 908B}
 $m3 = 22,5 - 0,0028 \cdot P[1]^3$ {OW 910}
 $m4 = 33,8 - 0,0008 \cdot P[1]^3$ {OW 910A}
 $m5 = 63,5 - 0,0005 \cdot P[1]^3$ {OW 910B}
 $m6 = 40,3 - 0,0003 \cdot P[1]^3$ {OW 916}
 $m7 = 26,9 - 0,0017 \cdot P[1]^3$ {OW 916A}
 $m8 = 27,8 - 0,0035 \cdot P[1]^3$ {OW 915}
 $m9 = 33,9 - 0,0005 \cdot P[1]^3$ {OW 915A}
 $m10 = 35,6 - 0,0035 \cdot P[1]^3$ {OW 915B}
 $m11 = 10 - 0,003 \cdot P[1]^3$ {OW 908}
 $m12 = 40,5 - 0,0093 \cdot P[1]^3$ {OW 915B}
 $m13 = 32,2 - 0,0145 \cdot P[1]^3$ {OW 908}
 $m14 = 25,3 - 0,0058 \cdot P[1]^3$ {OW 912}
 $m15 = 18,1 - 0,0029 \cdot P[1]^3$ {OW 912A}

$m_{\text{dot}}[1] = m1 + m2 + m3 + m4 + m5 + m6 + m7 + m8 + m9 + m10 + m11 + m12 + m13 + m14 + m15$

$T[1] = \text{Temperature}(\text{Water}; P=P[1]; h=h[1])$

$x[1] = \text{Quality}(\text{Water}; h=h[1]; P=P[1])$

"State 2"

$P[2] = P[1]$

$h[2] = h[1]$

$m_{\text{dot}}[2] = m_{\text{dot}}[1]$

$x[2] = \text{Quality}(\text{Water}; h=h[2]; P=P[2])$

"State 3"

$P[3] = P[2]$

$x[3] = 0$ [-]

$h[3] = \text{enthalpy}(\text{Water}; P=P[3]; X=x[3])$

$T[3] = \text{Temperature}(\text{Water}; P=P[3]; x=x[3])$

$v[3] = \text{volume}(\text{Water}; h=h[3]; P=P[3])$

$m_{\text{dot}}[3] = (1 - x[2]) \cdot m_{\text{dot}}[2]$

"State 4"

$P[4] = P[2]$

$x[4] = 1$ [-]

$h[4] = \text{enthalpy}(\text{Water}; P=P[4]; X=x[4])$

$T[4] = \text{Temperature}(\text{Water}; P=P[4]; x=x[4])$

$s[4] = \text{entropy}(\text{Water}; P=P[4]; x=x[4])$

$m_{\text{dot}}[4] = x[2] \cdot m_{\text{dot}}[2]$

"State 5"

$P[5] = P[7]$

$s_{\text{5s}} = s[4]$

$h_{\text{5s}} = \text{enthalpy}(\text{Water}; P=P[5]; s=s_{\text{5s}})$

"!Baumann rule"

$h_{\text{a}} = \text{enthalpy}(\text{Water}; P=P[5]; x=0)$

$h_{\text{b}} = \text{enthalpy}(\text{Water}; P=P[5]; x=1)$

$A = \eta_{\text{dt}} / 2 \cdot (h[4] - h_{\text{5s}})$

$h[5] = (h[4] - A \cdot (1 - h_{\text{a}} / (h_{\text{b}} - h_{\text{a}}))) / (1 + A / (h_{\text{b}} - h_{\text{a}}))$

$s[5] = \text{entropy}(\text{Water}; P=P[5]; h=h[5])$

$x[5] = \text{Quality}(\text{Water}; h=h[5]; P=P[5])$

$T[5] = \text{Temperature}(\text{Water}; P=P[5]; h=h[5])$

$m_{\text{dot}}[5] = m_{\text{dot}}[4]$

"State 6"

$P[6] = P[7]$

$h[6] = h[3]$

m_dot[6]=m_dot[3]
 x[6]=Quality(Water;h=h[6];P=P[6])

"State 7"

m_dot[7] = m_dot[5] + m_dot[6]
 h[7] = (h[5]*m_dot[5] + h[6]*m_dot[6])/m_dot[7]
 T[7]=Temperature(Water;P=P[7];h=h[7])
 x[7]=quality(Water;P=P[7];h=h[7])
 v[7]=Volume(Water;P=P[7];h=h[7])

"State 8"

P[8] = P[7]
 x[8]=0 [-]
 h[8]=enthalpy(Water;P=P[8];X=x[8])
 T[8]=Temperature(Water;P=P[8];x=x[8])
 v[8]=volume(Water;h=h[8];P=P[8])
 m_dot[8]=(1-x[7])*m_dot[7]

"State 9"

P[9]=P[7]
 x[9]=1 [-]
 h[9]=enthalpy(Water;P=P[9];X=x[9])
 T[9]=Temperature(Water;P=P[9];x=x[9])
 s[9] = entropy(Water;P=P[9];x=x[9])
 m_dot[9]=x[7]*m_dot[7]

"State 10"

s_10s=s[9]
 h_10s=enthalpy(Water;P=P[10];s=s_10s)
 "!Baumann rule"
 h_aLP=enthalpy(Water;P=P[10];x=0)
 h_bLP=enthalpy(Water;P=P[10];x=1)
 A_LP=eta_dt/2*(h[9]-h_10s)
 h[10]=(h[9]-A_LP*(1-h_aLP/(h_bLP-h_aLP)))/(1+A_LP/(h_bLP-h_aLP))
 s[10]=entropy(Water;P=P[10];h=h[10])
 x[10]=Quality(Water;h=h[10];P=P[10])
 T[10]=Temperature(Water;P=P[10];h=h[10])
 m_dot[10]=m_dot[9]

"State 11"

P[11] = P[10]
 x[11] = 0
 h[11] = enthalpy(Water;P=P[11];x=x[11])
 T[11] = Temperature(Water;P=P[11];x=x[11])
 v[11] = volume(Water;P=P[11];x=x[11])
 m_dot[11] = m_dot[10]

"State 12"

m_dot[12]=m_dot[11]
 h_12s=h[11]+v[11]*(P[12]-P[11])*100
 h[12]=h[11]+(h_12s-h[11])/eta_Pump1
 T[12]=Temperature(Water;P=P[12];h=h[12])
 x[12]=quality(Water;P=P[12];h=h[12])
 v[12]=Volume(Water;P=P[12];h=h[12])

"State 13"

m_dot[13] = Q_dot_Condenser*1000/(h[15]-h[14])
 h[13]=enthalpy(Water;T=T[13];P=P[13])
 v[13]=volume(Water;T=T[13];P=P[13])

"State 14"

m_dot[14]=m_dot[13]
 h_14s=h[13]+v[13]*(P[14]-P[13])*100
 h[14]=h[13]+(h_14s-h[13])/eta_Pump2
 T[14]=Temperature(Water;P=P[14];h=h[14])
 x[14]=quality(Water;P=P[14];h=h[14])

"State 15"

DELTA_P_Condenser=0,6 [bar]
 P[15]=P[14]-DELTA_P_Condenser

h[15]=enthalpy(Water;T=T[15];P=P[15])
 m_dot[15]=m_dot[14]

"!Energy calculations"

"Energy calculations"

W_dot_HP = m_dot[4]*(h[4]-h[5])/1000
 W_dot_LP = m_dot[9]*(h[9]-h[10])/1000
 W_dot_Pump1 = m_dot[11]*(h[12]-h[11])/1000
 W_dot_Pump2 = m_dot[13]*(h[14]-h[13])/1000
 W_dot_Pumps = W_dot_Pump1+W_dot_Pump2
 W_dot_Gen = W_dot_HP+W_dot_LP
 W_dot_Aux = W_dot_Pumps+W_dot_400V+W_dot_CoolingTower+W_dot_GasExtraction+W_dot_T&G+W_dot_Other
 W_dot_Net=W_dot_Gen-W_dot_Aux

"Auxiliary power consumption"

W_dot_400V=3,89*W_dot_Gen/1000
 W_dot_T&G=2,3*W_dot_Gen/1000
 W_dot_CoolingTower = 4,13*Q_dot_Condenser/1000
 W_dot_GasExtraction=4,13*Q_dot_Condenser/1000
 W_dot_Other=3,04*W_dot_Gen/1000

"Cooling capacity of Condenser"

Q_dot_Condenser = m_dot[10]*(h[10]-h[11])/1000

Case 4b: Topping unit, optimized, fixed pressure for main turbine

"Wells"

m1=38-0,0017*P[1]^3	{OW 908A}
m2=25,8-0,0017*P[1]^3	{OW 908B}
m3=22,5-0,0028*P[1]^3	{OW 910}
m4=33,8-0,0008*P[1]^3	{OW 910A}
m5=63,5-0,0005*P[1]^3	{OW 910B}
m6=40,3-0,0003*P[1]^3	{OW 916}
m7=26,9-0,0017*P[1]^3	{OW 916A}
m8=27,8-0,0035*P[1]^3	{OW 915}
m9=33,9-0,0005*P[1]^3	{OW 915A}
m10=35,6-0,0035*P[1]^3	{OW 915B}
m11=10-0,003*P[1]^3	{OW 908}
m12=40,5-0,0093*P[1]^3	{OW 915B}
m13=32,2-0,0145*P[1]^3	{OW 908}
m14=25,3-0,0058*P[1]^3	{OW 912}
m15=18,1-0,0029*P[1]^3	{OW 912A}
m16=30-0,0018*P[1]^3	{OW 912}
m17=18,1-0,0019*P[1]^3	{OW 912A}

m_dot[1]=m1+m2+m3+m4+m5+m6+m7+m8+m9+m10+m11+m12+m13+m14+m15+m16+m17

T[1]=Temperature(Water;P=P[1];h=h[1])
 x[1]=Quality(Water;h=h[1];P=P[1])

"State 2"

P[2] = P[1]
 h[2]=h[1]
 m_dot[2]=m_dot[1]
 x[2]=Quality(Water;h=h[2];P=P[2])

"State 3"

P[3]=P[2]
 x[3]=0 [-]
 h[3]=enthalpy(Water;P=P[3];X=x[3])
 T[3]=Temperature(Water;P=P[3];x=x[3])
 v[3]=volume(Water;h=h[3];P=P[3])
 m_dot[3]=(1-x[2])*m_dot[2]

"State 4"

P[4]=P[2]
 x[4]=1 [-]
 h[4]=enthalpy(Water;P=P[4];X=x[4])
 T[4]=Temperature(Water;P=P[4];x=x[4])

s[4]=entropy(Water;P=P[4];x=x[4])
m_dot[4]=x[2]*m_dot[2]

"State 5"

P[5] = P[7]
s_5s=s[4]
h_5s=enthalpy(Water;P=P[5];s=s_5s)
"!Baumann rule"
h_a=enthalpy(Water;P=P[5];x=0)
h_b=enthalpy(Water;P=P[5];x=1)
A=eta_dt/2*(h[4]-h_5s)
h[5]=(h[4]-A*(1-h_a/(h_b-h_a)))/(1+A/(h_b-h_a))
s[5]=entropy(Water;P=P[5];h=h[5])
x[5]=Quality(Water;h=h[5];P=P[5])
T[5]=Temperature(Water;P=P[5];h=h[5])
m_dot[5]=m_dot[4]

"State 6"

P[6] = P[7]
h[6] = h[3]
m_dot[6]=m_dot[3]
x[6]=Quality(Water;h=h[6];P=P[6])

"State 7"

m_dot[7] = m_dot[5] + m_dot[6]
h[7] = (h[5]*m_dot[5] + h[6]*m_dot[6])/m_dot[7]
T[7]=Temperature(Water;P=P[7];h=h[7])
x[7]=quality(Water;P=P[7];h=h[7])
v[7]=Volume(Water;P=P[7];h=h[7])

"State 8"

P[8] = P[7]
x[8]=0 [-]
h[8]=enthalpy(Water;P=P[8];X=x[8])
T[8]=Temperature(Water;P=P[8];x=x[8])
v[8]=volume(Water;h=h[8];P=P[8])
m_dot[8]=(1-x[7])*m_dot[7]

"State 9"

P[9]=P[7]
x[9]=1 [-]
h[9]=enthalpy(Water;P=P[9];X=x[9])
T[9]=Temperature(Water;P=P[9];x=x[9])
s[9] = entropy(Water;P=P[9];x=x[9])
m_dot[9]=x[7]*m_dot[7]

"State 10"

s_10s=s[9]
h_10s=enthalpy(Water;P=P[10];s=s_10s)
"!Baumann rule"
h_aLP=enthalpy(Water;P=P[10];x=0)
h_bLP=enthalpy(Water;P=P[10];x=1)
A_LP=eta_dt/2*(h[9]-h_10s)
h[10]=(h[9]-A_LP*(1-h_aLP/(h_bLP-h_aLP)))/(1+A_LP/(h_bLP-h_aLP))
s[10]=entropy(Water;P=P[10];h=h[10])
x[10]=Quality(Water;h=h[10];P=P[10])
T[10]=Temperature(Water;P=P[10];h=h[10])
m_dot[10]=m_dot[9]

"State 11"

P[11] = P[10]
x[11] = 0
h[11] = enthalpy(Water;P=P[11];x=x[11])
T[11] = Temperature(Water;P=P[11];x=x[11])
v[11] = volume(Water;P=P[11];x=x[11])
m_dot[11] = m_dot[10]

"State 12"

m_dot[12]=m_dot[11]
h_12s=h[11]+v[11]*(P[12]-P[11])*100

```

h[12]=h[11]+(h_12s-h[11])/eta_Pump1
T[12]=Temperature(Water;P=P[12];h=h[12])
x[12]=quality(Water;P=P[12];h=h[12])
v[12]=Volume(Water;P=P[12];h=h[12])

```

"State 13"

```

m_dot[13] = Q_dot_Condenser*1000/(h[15]-h[14])
h[13]=enthalpy(Water;T=T[13];P=P[13])
v[13]=volume(Water;T=T[13];P=P[13])

```

"State 14"

```

m_dot[14]=m_dot[13]
h_14s=h[13]+v[13]*(P[14]-P[13])*100
h[14]=h[13]+(h_14s-h[13])/eta_Pump2
T[14]=Temperature(Water;P=P[14];h=h[14])
x[14]=quality(Water;P=P[14];h=h[14])

```

"State 15"

```

DELTA_P_Condenser=0,6 [bar]
P[15]=P[14]-DELTA_P_Condenser
h[15]=enthalpy(Water;T=T[15];P=P[15])
m_dot[15]=m_dot[14]

```

"!Energy calculations"

"Energy calculations"

```

W_dot_HP = m_dot[4]*(h[4]-h[5])/1000
W_dot_LP = m_dot[9]*(h[9]-h[10])/1000
W_dot_Pump1 = m_dot[11]*(h[12]-h[11])/1000
W_dot_Pump2 = m_dot[13]*(h[14]-h[13])/1000
W_dot_Pumps = W_dot_Pump1+W_dot_Pump2
W_dot_Gen = W_dot_HP+W_dot_LP
W_dot_Aux = W_dot_Pumps+W_dot_400V+W_dot_CoolingTower+W_dot_GasExtraction+W_dot_T&G+W_dot_Other
W_dot_Net=W_dot_Gen-W_dot_Aux

```

"Auxiliary power consumption"

```

W_dot_400V=3,89*W_dot_Gen/1000
W_dot_T&G=2,3*W_dot_Gen/1000
W_dot_CoolingTower = 4,13*Q_dot_Condenser/1000
W_dot_GasExtraction=4,13*Q_dot_Condenser/1000
W_dot_Other=3,04*W_dot_Gen/1000

```

"Cooling capacity of Condenser"

```

Q_dot_Condenser = m_dot[10]*(h[10]-h[11])/1000

```