



ELECTRICAL PROTECTION IN GEOHERMAL POWER PLANT PROJECTS

José R. Estévez

LaGeo S.A. de C.V.

15 Avenida Sur, Colonia Utila

Santa Tecla, La Libertad

EL SALVADOR C.A.

jestevez@lageo.com.sv

ABSTRACT

In order to ensure that a geothermal power plant is reliable and efficient, an electrical protection system design is of the utmost importance. The electrical protection system integrates a variety of equipment into the different systems found in such a power plant. A successful project includes an engineering team and a project manager, with each party possessing a deep understanding of the general process of each area necessary for the construction of a geothermal power generation plant. The purpose of this report is to provide a representative overview of the electrical protection system in a geothermal power plant project, as well as to serve as a basis for performance, organization and results for future projects in El Salvador. The report clearly identifies the location of the electrical protection system in a power plant, focusing on the protection relays, and describing the main processes to achieve an adequate system of protection. Furthermore, schematics and general concepts applied in geothermal power plant studies have been incorporated as well. The information and dates obtained are based on documents from the Ahuachapán and Berlin power plants in El Salvador and the Hellisheidi power plant in Iceland.

1. INTRODUCTION

El Salvador is situated on the Pacific coast of Central America. It is located along the "Circum Pacific ring of fire", where the Cocos plate subducts under the Caribbean plate. Since 1975 geothermal energy has been one of the main sources of electricity in the country. In 2008, the total installed capacity of electrical power in El Salvador was 1,422 MW, with an annual growth of 3.7%. Notably, only 92% of the installed capacity is considered available, i.e. 1,309 MW. In that year, the total resource injection showed that 36.1% came from thermal power plants, 36.5% from hydroelectric power plants, 25.5% was contributed by the production of geothermal energy, and biomass generation supplied 1.9% of the production. Generation of renewable resources accounts for 63.9% of injections into the national grid system. During this year the growth in demand was covered mainly by hydroelectric and geothermal resources; significant volumes of injections for these resources reflect a growth of 17.2% and 9.9%, respectively (SIGET, 2008).

El Salvador covers an area of 21,000 km², and its national transmission system is composed of 37 lines of 115 kV, which have a total length of 1,024 km. There are 24 substations and power lines and two

230 kV transmission systems that interconnect El Salvador with Guatemala and Honduras (Figure 1). The length of the power lines from El Salvador to Guatemala and Honduras is 14.6 km and 92.9 km, respectively. It is estimated that by the year 2010 the SIEPAC line will be in service, interconnecting the countries of Central America. The SIEPAC line will be approximately 1,800 km in length; it will have a level voltage of 230 kV and an interconnection capacity of 300 MW (SIGET, 2008).

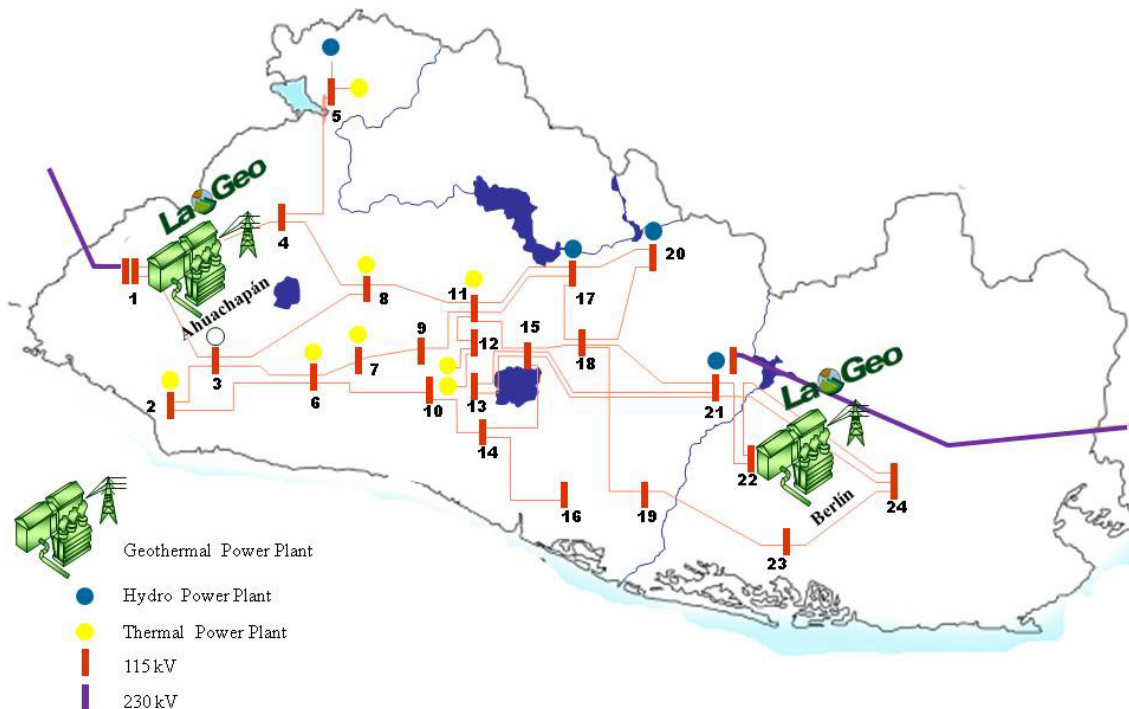

FIGURE 1: The transmission power system in El Salvador

There are two geothermal power plants in El Salvador that are responsible for the generation of geothermal energy. The development of new power generation units is a priority for the support and development needed to participate in the electrical market. This report is part of a collaboration seeking to continually improve the design processes of the power systems for new power plants, as there appear to be new geothermal power plant projects to be developed in the future.

The execution of a new geothermal plant project involves the development of multiple disciplines. The success of the project is embedded in the understanding of how to integrate the processes. This report focuses on the integral parts of power systems in a power plant, paying special attention to the electrical protection of the principal electrical equipment and protection relays. This report is based on developments from previous experience, and on technical information obtained from the power plants in El Salvador and Iceland.

2. MAIN ELECTRICAL EQUIPMENT IN GEOTHERMAL POWER PLANTS

2.1 Energy conversion process description

A variety of energy conversion systems are used for the generation of geothermal power throughout the world. The single-flash steam plant is the mainstay of the geothermal power industry. Often it is the first power plant installed at a newly developed liquid-dominated geothermal field. Such plants constitute over 42% of the total installed geothermal power capacity in the world (Dipippo, 2008).

In a single-flash power plant (Figure 2), the process consists of taking a two-phase mixture of liquid and steam that is produced by the well. The quality of this working fluid depends on the reservoir properties and the wellhead pressure. A steam separator is a device used to separate water from steam in a two-phase flow. This equipment creates a vortex that drives the heavy particles in the flow to one side due to centrifugal force.

This, in turn, produces a stream of steam that is used to drive the turbine. The turbine is the core unit of a geothermal power plant and the steam is the source that moves to the generator where the mechanical energy is transformed into electrical energy. This energy is created at a lower voltage level than the transmission voltage. Then a step-up transformer is used to inject the electrical energy into the transmission network.

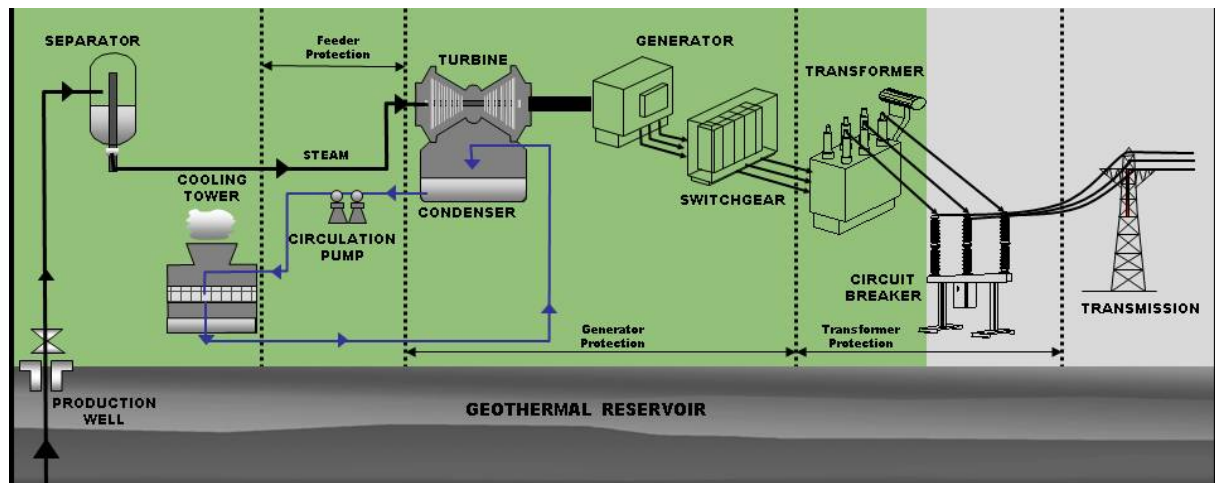

FIGURE 2: Single-flash process in a geothermal power plant

After developing the work on the turbine, the steam continues on to the condenser. The function of the condenser is to reduce the pressure at the turbine outlet and thus extract more energy from the steam flowing from the turbine. An additional purpose of the condenser is to condense the steam into a liquid form since it requires much less work to pump an incompressible liquid than compressible gas or steam. The condenser shown in Figure 2 is of a direct-contact type. Non-condensable gases are extracted from the condenser by steam ejectors. In order to create water circulation from the condenser and reduce the pressure, pumps are used which are equipment of major electrical internal consumption in the process. As the main equipment, needed in the process, comes to a substantial cost and requires a large capital investment, the system must be used as much as possible within the applicable constraints of security and reliability of supply in order to maximize the return on this outlay. Based on this concept, this report will centre on the following pieces of electrical equipment: the generator, the unit transformer and the pumps. Also, it is important to note that the power system should operate in a safe manner at all times. Thus, it is necessary to provide a suitable protection system for all of the equipment.

A modern generating unit is a complex system comprised of: the generator stator winding, the associated transformer and unit transformer, as well as the rotor with its field winding and excitation system, and the prime mover with its associated auxiliaries (Figure 3). Errors of many kinds can occur within this system for which diverse forms of electrical and mechanical protection are required. The amount of protection applied will be governed by economic and technical considerations, taking into account the value of the machine, the value of its output to the plant owner and the recommendation of the respective grid company.

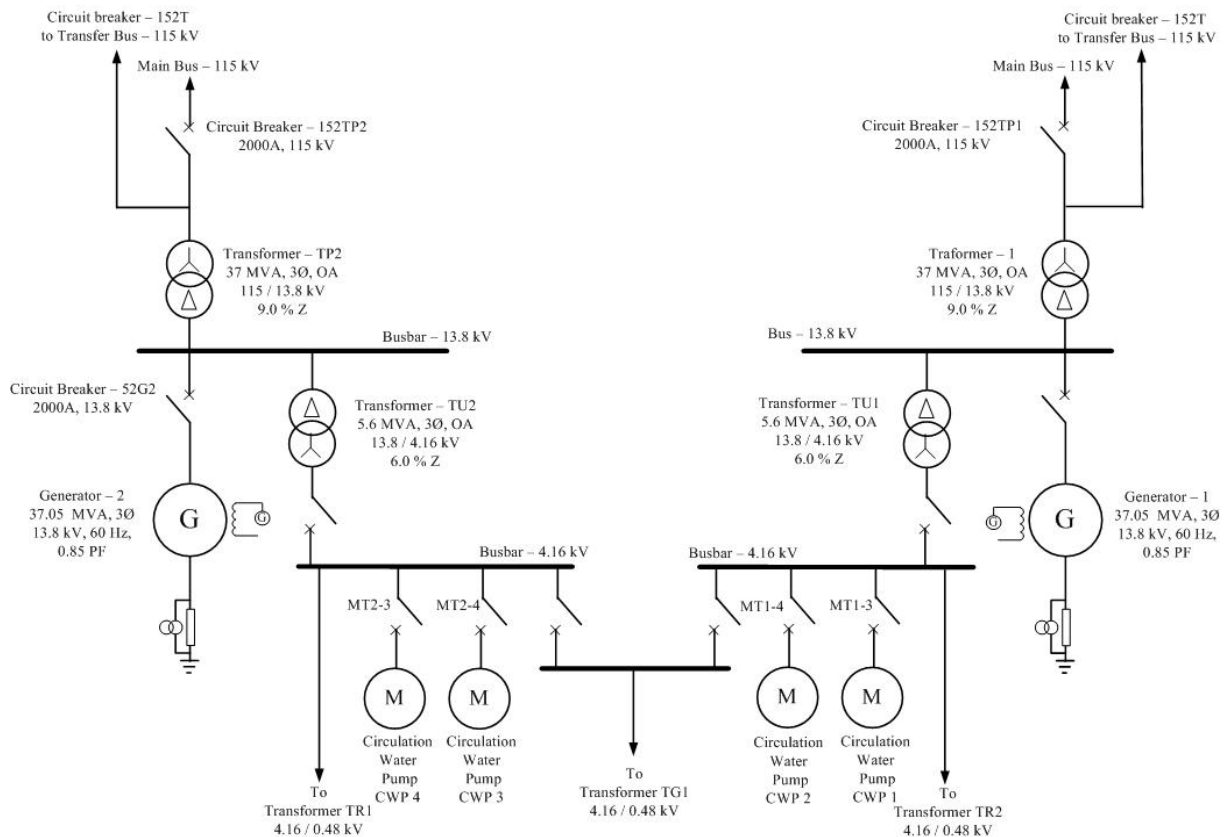

FIGURE 3: Berlin power plant one-line diagram, units 1 - 2

2.2 Generator

Generators convert mechanical energy into electricity (Figure 4). The conversion of the fundamental energy into its electrical equivalent normally requires a prime mover to develop the mechanical power as an intermediate stage. The nature of this machine depends upon the source of energy. In geothermal power plants, generators are based on steam turbines that use condensing units.

A simplified functionality of a generator can be described as follows. Electromagnets are developed by circulating direct current through loops of wire wound around stacks of magnetic steel laminations. These are called field poles, and they are mounted on the perimeter of the rotor. The rotor is attached to the turbine shaft, and rotates at a fixed speed. When the rotor turns, it causes the field poles (the electromagnets) to move past the conductors mounted in the stator. This, in turn, causes electricity to flow and a voltage to develop at the generator output terminals.

The harsh environmental conditions, due especially to the presence of H_2S in the geothermal fields, impose a scrupulous choice of materials for the electric equipment and for the related construction techniques. The equipment



FIGURE 4: The generator of unit 1, Ahuachapán

should contain particular resistive characteristics against aggressive action from the environment. Under these operational conditions the windings and the electric connections of the stator and rotor should be insulated with a class F material and against a class B temperature rise. All the conductors in contact with the air should be protected against the hostile actions of H₂S. Given the particular environmental conditions, it is necessary that all the components of the machinery be built with materials capable of withstanding the corrosive and erosive action to which they are exposed. All the parts in contact with the cooling water should fulfil AISI 316.

This unique environment of geothermal power plants is taken into account in the preparation of technical specifications. For example, the generator housing technical specification of the Hellisheidi geothermal power plant states the following: “The generator and exciter shall be totally enclosed in a mutual bolted housing to seal out the corrosive gases in the atmosphere. The protection class of the housing shall be at least IP54 in accordance with IEC 60034-5. The enclosure shall be equipped with makeup fans and carbon filters to purify and eliminate H₂S from the circulating air.”

Technical data of the generators in El Salvadorian geothermal power plants are shown in Table 1.

TABLE 1: Generator data from geothermal power plants in El Salvador

Power plant	Rated power (MVA)	Rated voltage (kV)	Rated current (A)	Rated speed (RPM)	F.P.	Insulation	Brand
Berlin Unit 1-2	37.047	13.8	1,550	3,600	0.850	F	Fuji
Berlin Unit 3	51.764	13.8	2,165	3,600	0.850	F	Brush
Ahuachapán Unit 1-2	37.500	13.8	1,569	3,600	0.800	F	Fuji
Ahuachapán Unit 3	40.000	13.8	1,674	3,600	0.875	F	Fuji

For the calculations and design of generator protections, certain information is utilized. Such information is provided by the manufacturer, and must be requested by the client in some cases. This data is also required by the designer of the system for entering parameters for the new generator into the system model. In El Salvador, the grid company requires information about the following technical data (Table 2) from the power plant owner:

TABLE 2: Technical data required in El Salvador from power plant owners

Performance curves	Technical data
Permitted duration of negative sequence current	General data
Generator capability diagram	Impedances
Generator efficiency vs. output	Time constants
Open circuit and short circuit characteristics	Excitation system
Generator vee curves	Operation data
	Data of prime movers and governors

2.3 Transformers

In power stations, power is usually generated at a voltage in the range of 11-25 kV. The power is then transformed up to higher voltages, between 110 and 1,000 kV, and to a lower current for transmission over long distances. This results in a reduction of voltage drops and transmission losses, which are proportional to the square of the current. The transformer that steps up the output power of a generator to transmission levels is called the unit transformer or generator step-up transformer (Figure 5). The transformer that connects the output of the generator with the plant itself, feeding power back to the plant, is called the unit service transformer or station auxiliary transformer.



FIGURE 5: Unit transformer, Berlin unit 3

In geothermal power plants in El Salvador, the rating of the unit service transformer is normally about 6-8% of the unit transformer. The power plants generate power at 13.8 kV and the transmission level is between 115 and 230 kV.

The considerations for a transformer protection package vary with the application and importance of the transformer. To reduce the effects of thermal stress and electrodynamic forces, it is advisable to ensure that the protection package used minimizes the

time for disconnection in the event of a fault occurring within the transformer. This results in time-delayed protection due to downstream co-ordination requirements. However, time-delayed fault clearance is unacceptable on power transformers used in generator applications, due to system operation/stability and the cost of the repair/length of outage considerations.

The two types of transformers that are most common are: air-cooled (dry-type) and oil-filled. The transformer rating increases with improved cooling methods. The technical data of the unit transformers in geothermal power plants in El Salvador are shown in Table 3.

TABLE 3: Unit transformer data from geothermal power plants in El Salvador

Power plant	Rated power (MVA)	Rated low voltage (kV)	Rated high voltage (kV)	Cooling	Impedance (%)	Connection type	Type	Brand
Berlin Unit 1-2	37,000	13.8	115	OA	8.8	Star-Delta	Oil-filled	Delta-Star Inc.
Berlin Unit 3	52,000	13.8	115	OA	12.15	Star-Delta	Oil-filled	Hua peng
Ahuachapán Unit 1	35,000	13.8	115	OA	7.84	Star-Delta	Oil-filled	Italtranfo
Ahuachapán Unit 3	40,000	13.8	115	ONAN	8.49	Star-Delta	Oil-filled	Jeumont-Schneider

2.4 Pumps

The pumps are used to extract water from geothermal steam condensate at the saturation point which is located on the vacuum condenser, sending the hot water to the cooling towers; similarly, pumps are used to build up vacuum. After the cooling towers remove the heat, the cold water returns to the main condenser and other heat exchangers. These extraction pumps are driven by an electric motor. The pump and motor unit (Figure 6) including all the components are designed and constructed to safely withstand the stresses involved in the repeated “direct-on-line” starting at full rated voltage and frequency.

The motors that are coupled with the pumps are usually located outdoors. These pumps have to work for long periods of time; one of the requirements that should be taken into consideration is the type of motor installed. Usually the specifications used for these motors are: asynchronous, three-phase and squirrel cage rotor type, which are to be started-up at full voltage and continuous service. The motors have a feed system either with an earthed neutral through a limiting resistance or are isolated. The motors are designed for continuous running and are capable of performing a type S1 duty.

Taking into account the particular geothermal environmental conditions and considering the actual importance of this equipment in this process, the materials required for this motor must be resistant to chemical corrosion, erosion and vibration. The following are unsuitable materials, unless they are adequately protected: silver, copper, copper alloys and carbon steel. Materials that may be used, even if slightly prone to corrosion, are zinc and cadmium, the performances of which may be improved by a chrome-coating treatment. The use of AISI 316 and AISI 304 stainless steel, and aluminium alloys, are recommended. Excellent resistance is provided by plastics in general, such as PVC, fibreglass, and teflon, etc.

All motors need protection, but fortunately, the more fundamental problems affecting the choice of protection are independent of the type of motor and the type of load to which it is connected. Motor characteristics must be carefully considered when applying protection. This may be obvious; however, it is emphasized because it applies more to motors than to other items of the power system in the plant. Technical data of the motor circulation pumps in geothermal power plants in El Salvador are shown in Table 4.



FIGURE 6: Circulation pumps in the Berlin power plant, unit 1

TABLE 4: Circulation pump motor data from geothermal power plants in El Salvador

Power plant	Rated power (kW)	Amperes (A)	Voltage (kV)	Insulation	Power factor	Efficiency (%)	Type	Brand
Berlin unit 1-2	372	65	4.16	B	84.7	93.6	Vertical	GE Motors
Berlin unit 3	930	172	4.16	B	79.0	N/A	Vertical	ABB
Ahuachapán unit 1 - 2 (A-B)	540	93	4.16	B	88.8	93.6	Vertical	Mitsubishi Electric
Ahuachapán unit 3 (A-B)	750	135	4.16	B	N/A	N/A	Vertical	Fuji Electric

3. PROTECTIVE RELAY IMPLEMENTATION PROCESS IN A POWER PLANT PROJECT

3.1 Electrical area in the power plant project

It is common for a project manager to deal with many specialties and it is necessary to understand the basic processes of each of the project areas for the administration to be successful. The purpose of this section is to describe the process, as well as the main activities that are undertaken in order to build the power system, as part of the power plant project. This will be the base system for the implementation of the protective relays that will be our main focus.

In the development of a new geothermal power plant it is usual to split the engineering work into three main areas: civil, mechanical and electrical. The electrical area has two basic branches: power systems and control systems. As seen in Figure 7, electrical protections are organized under the electric power systems area; this facilitates the organization of this category and its activities, although the application of protective relays integrates the two areas.

3.2 Implementation of the power plant project

In the basic process of the development of power systems in the project (Figure 8) and its challenges, the following phases have been established: feasibility study, design, procurement, construction and start up, and final acceptance.

3.2.1 Feasibility study

The analysis and evaluation of a proposed project attempts to determine if it is technically feasible, is feasible within the estimated cost, and if it will be profitable. This section deals with some of the topics that are part of the geothermal power plant project's technical feasibility study, e.g. the power systems part.

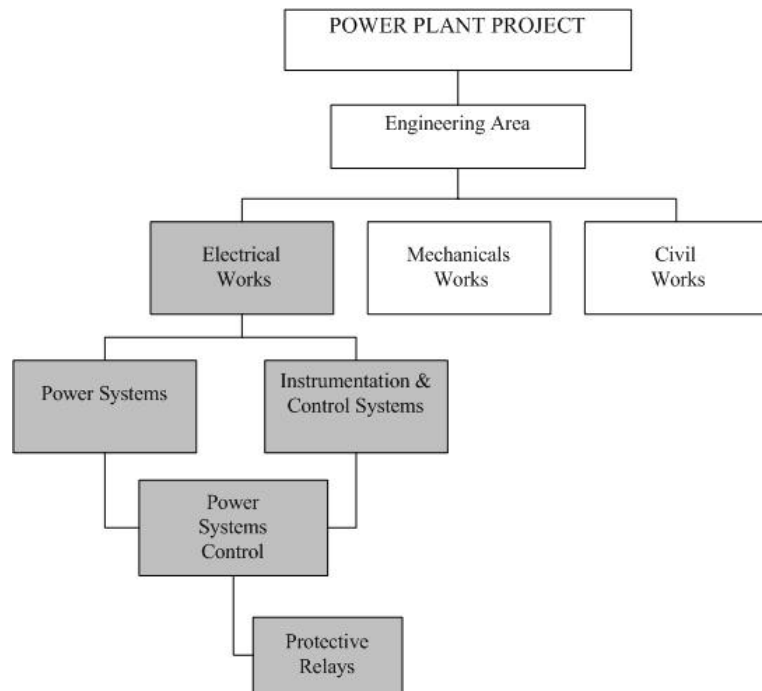

FIGURE 7: Organization in a power plant project

Pre-design:

One important activity in the pre-design phase of the power system in the power plant is the development of the one-line diagram of the intended power plant system. This diagram allows for a clear discussion of the design and specifications of the major electrical components in the power plant.

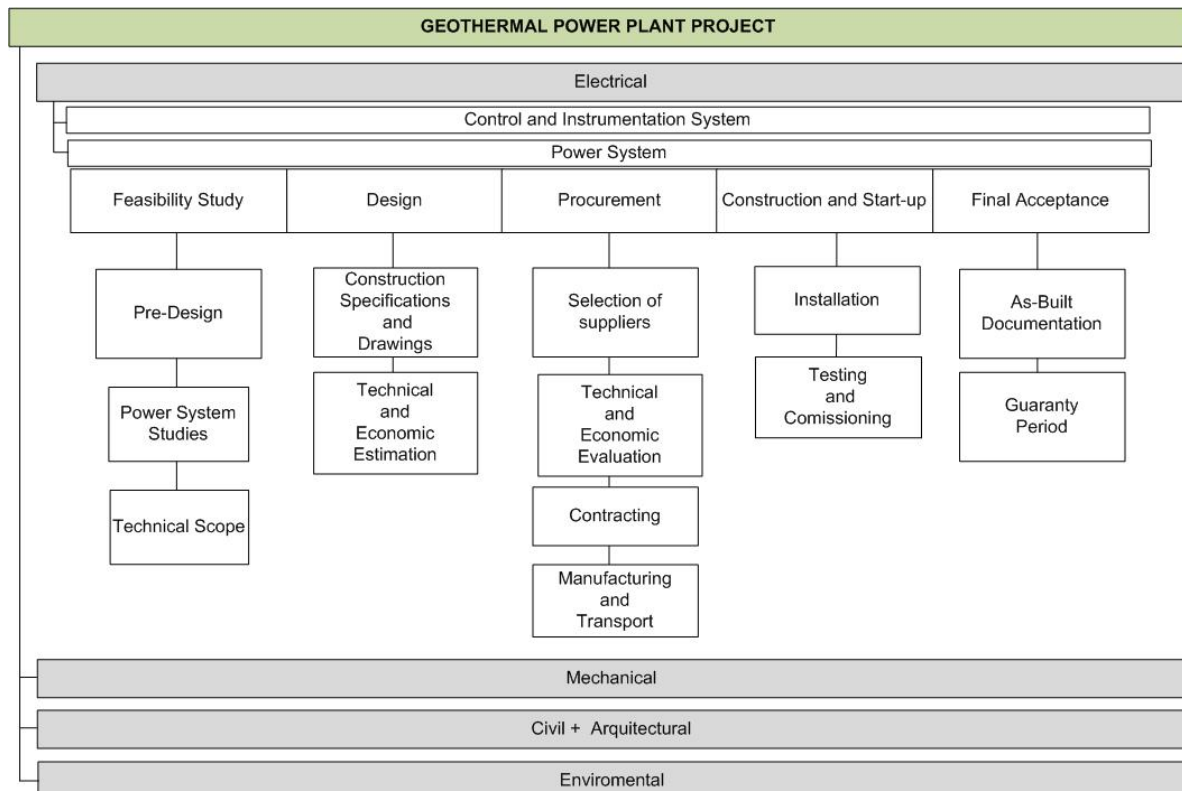

FIGURE 8: The basic process of development of power systems in a power plant project

The relationship between generators, transformers, transmission lines and sources of station service power are established, as well as the electrical location of the associated power circuit breakers and their control and protection functions. The estimated power data in the feasibility plant studies will be used as a starting point for the calculation of the power system components and their arrangement. The design features for the one-line diagram that should be taken into consideration by the designers are: safety, reliability, simplicity of operation, flexibility to deal with contingencies and the ability to accommodate system changes. After the one-line diagram of the plant has been completed, a report must be filed where the choice of design is justified by technical and economic studies.

Power systems studies:

The planning, design and operation of a power system requires continual and comprehensive analyses to evaluate the current system performance, as well as to establish the effectiveness of alternative plans for system expansion. After the preparation of the one-line diagram, the next step in the design process is the fault current calculations. In this part of the power system study the magnitude of the currents that flow during a fault is determined, and the values describing the system model take into account the following data: the short-circuit capacity, power transformer impedances, and generator reactance. With these data, the designer will have more information with which to write the technical specifications for main equipment such as the transformers, generators and switchgears. Before this data can be obtained, it is difficult to establish, for example: the size, insulation capacity, interrupting ratings, and cable ampacity, etc.

This information is requested by the transmission company to determine the different levels of short circuits at the nodes, which are adjacent to the connection of a new generating unit. It will be connected to the existing substation, and will estimate the symmetrical and asymmetrical flows of the network failures to the exit point of the unit. The inclusion of a new generating unit in the system will lead to a greater effort in the HV circuit breaker, especially for three-phase faults which are located near the installed circuit breaker. It then becomes necessary to verify that the resulting short circuit remains below the capacity of the relevant equipment in the substation.

This information will later be useful in the setting process of protection equipment. It is essential to know the load flow and the fault current distribution throughout the system and the voltages in different parts of the system due to the fault. With this information, the designer can define boundary values of the current at the relay. Depending on the philosophy used, the fault will be cleared or discriminated. A number of software programmes are commercially available to perform these studies.

Technical scope:

The project definition consists of, amongst other things, the technical scope, the economic and technical estimation and the strategy for procurement. A technical scope is a description of what shall be included in the contract (or the individual phase if the power plant is divided into phases).

In the case of the protection system, the main items are: the electrical relay protection system for the turbine/generator unit, the relay protection system for the transformers in the power plant, the relay protection for the switchgear, and the communication links to the station control system.

3.2.2 Design

At the design stage, documents for the procurement process are prepared. These documents outline the construction specifications and drawings describing the equipment location; the design features and the construction requirements are given in sufficient detail to allow for accurate bids; and to provide for the construction of the project without significant change of orders and claims.

Construction specifications and drawings:

In this step, the designers create a detailed design in which the technical characteristics to be requested

for the plant are decided. It involves consideration of equipment sizing, reliability constraints, performance requirements, codes and standards, all directed toward requirements for successful specification, construction, commissioning and start-up.

The designers must also prepare the technical specifications that the bidders must fulfil so their bid will be taken into consideration. There must be measurable parameters (e.g. technical and economic evaluation) that constitute the minimum criteria. If the criteria are not met by the bidder the bid is rejected.

Construction drawings should be complete and based on commercially available equipment, industry recognized construction and installation techniques. Details of equipment design and installation, wiring and conduits should be complete to minimize the need for field revision.

Technical and economic estimation:

The estimated cost will be used as a point of reference when analyzing a number of bids. The best bid will be negotiated in order to obtain the most advantageous offer for the power plant. The estimated cost should remain private until the bidding process is opened.

3.2.3 Procurement

The acquisition of goods and commodities for a new power plant is obtained at the best possible price for the owners, and in the right quality and quantity. Further, it is obtained from the right source, and at an advantageous time. Procurement may also involve a tendering and this usually begins with the process of searching the market for bidders.

Selection of suppliers:

In the Hellisheidi power plant project in Iceland the following tendering method was used during the selection of satisfactory qualified suppliers: In order to effectively select distributors an admission criterion was set, where economic capacity, finance, and technical capability were the main criterion factors. The aforementioned criteria must be met in order for the said distributor to be included within the contractual process. Only those suppliers who comply with the admission conditions will continue through to the second stage of the selection process. For the control and protective device in the Hellisheidi power plant the criteria excluded all but 2-5 participants with the highest score, who were selected to continue into the second phase of the selections. The factors which were evaluated and considered in the first stage are reviewed in detail in Table 5.

TABLE 5: An example of weighing factors in the selection process of qualified suppliers for the electrical part

No.	Weighing factors for the electrical part	Value	Score
1	Technical quality and market position of the equipment offered	0.25	
2	Experience with similar work in this area, the last 5 years	0.25	
3	Financial strength (turnover) and number of staff of interested parties and the department that will implement the project	0.10	
4	Education and experience of the major key personnel	0.20	
5	Services in the country	0.15	
6	Quality management, environment, and security	0.05	
	Sum of individual values	1.00	
	Total scores (Wt)		

Technical and economic evaluation:

Only those that comply with the technical and economical specifications will be considered after the careful evaluation of the first stage requirements of each individual offer. In the Hellisheidi power

plant project the engineering group that was awarded with the design of the project, compared prices and evaluated the quality of the products and services in accordance with the technical specifications.

There are several ways to weigh this assessment in order to make a selection that is economical and technically more attractive to competitors. In the Hellisheidi power plant project, this evaluation was based 70% on the tender price and 30% on the technical area, which resulted in a total score that was the sum of both the technical score and price score.

$$S = Sp + St$$

where Sp is the price score = $70 \times Fm/F$;
 St is the technical score = $30 \times Wt$;
 Fm is the lowest Tender price;
 F is the price of the bid being evaluated;
 Wt is the sum of scores assigned to the bid being evaluated.

The tender and equipment scores were calculated according to Table 6:

TABLE 6: Tender and equipment score factors

No.	Item	Weight	Score
1	Education and experience of key personnel assigned to the project	0.35	
2	Evaluation of technical quality of equipment and systems, with respect to information filled in the respective tender forms.	0.45	
3	Tender experience in projects comparable to the one described in these documents, during the past 5 years	0.2	
	Sum of individual weights	1.0	
	Total of scores (Wt)		

The supplier who fulfils both the technical and economical specifications, and in addition offers the lowest price, or makes an economically advantageous offer, will be awarded the project. Once the best offer is defined, the negotiation procedure starts. And during the negotiation, agreements will be made based on the viability and the technology of the project.

Contracting:

A contract is a legally binding agreement between the parties identified in the agreement to fulfil all the terms and conditions outlined in the agreement. There are some documents that form part of the legal agreement in the following order: contract agreement, scope of supply, price schedule, revised performance condition, minutes of meetings (negotiation meetings), proposal specification documents, revised tender.

3.2.4 Construction and start-up

The process of construction and start-up (Figure 8) consists of the following processes: installation, commissioning and start-up. At this stage it is important to define between the owner, the designer, the contractor and the business planning, organization of staff and the delivery of documents.

Installation:

During the installation process, it is common to perform visual inspections and tests in order to ensure that completed installations are in accordance with the manufacturer's specifications and the latest engineering and design information. Electrical test activities are frequently performed on the

TABLE 7: General test requirements of equipment

GENERAL TEST REQUIREMENTS
Survey of system fundamental documents
Schematic diagram Block diagram One-line diagram Control sequence diagram Wiring diagram Interconnection diagram Circuit layout and routing diagram Short-circuit coordination study
Listing of critical system equipment
Sample commissioning plan
Initial commissioning (kick-off) meeting Review initial statement of work (SOW) Review drawing submittals Approval meeting Systems operation document (SOD) Submit functional performance tests (FPTs) Quality assurance Review FPTs Make changes to FPTs FPT approval Systems operate Customer taking over
Special precautions and safety
Planning the test programme
Visual check of all wiring De-energized component testing Continuity checking of control circuits Field inspection and installation checks Energized functional testing of control circuits Commissioning of relays (See Section 5) Megger testing of power circuits Phase out testing of power circuits Energizing of main equipment Service testing Post acceptance tests
Test equipment
Reports, forms, and records

equipment, according to the IEEE guide for the commissioning of electrical systems in hydroelectric power plants (Table 7):

Insulation resistance testing of electrical equipment and cables is then performed. Continuity tests and a follow-up test are performed after that: to verify the cable routing, to check the initial operation of uncoupled motors (phase rotation check) and a functional test of valves and sensors. Once this is done then the inspection and testing of motor control centres and switchgear can be done, along with the verification of cable terminations in accordance with design documents. The individual equipment test procedures are typically provided by the equipment manufacturers and performed by the individual contractor or, as in the case of the Hellisheidi power plant, the testing team that is part of the engineering group. These test procedures are typically provided by the equipment manufacturers.

Testing and commissioning:

The electrical systems' commissioning process is used to increase the reliability of the electrical power systems after installation by identifying problems and providing a set of baseline values for comparison with subsequent routine tests. To set up a commissioning process it is necessary to define the following aspects: the general commissioning criteria, the commissioning plan, the documentation requirements, the verification procedures, the system functional performance tests, the corrective measures and the documentation and acceptance procedures.

The commissioning programmes contain the individual testing of equipment which must be completed before commissioning the system. Following that is the verification of the component interconnection against the design document, and the functional testing of the system as a whole. To develop a good plan for commissioning, it is necessary for the engineering group to have all the information on the equipment and system. With this information, it is possible to define an equipment main list and sequence of tests (time schedule) depending on their role and importance in the system.

Commissioning tests are usually performed by contractors or the manufacturers, and witnessed and approved of by an objective party e.g. the engineering group. Since they operate through the interaction of many teams, several manufacturers are involved. This is one aspect to be taken into account when developing the commissioning plan. In the process of test development, it is very

important not to incur costs and time losses. In order to test a system, it is required that its associated equipment must have been checked and that inspection tests should be completed. Sufficient time should be allocated to define the inspections (factory acceptance tests, pre-tests etc.) required, to perform the check and to document the results. The success of a test programme depends on the development and review of the test records and reports from the testing and operations of the personnel and system management.

Based on the Engineer Manual (U.S. Army Corps of Engineers, 1994), Table 7 was prepared. In this table the technical requirements are stated for a test programme. There are different cases for some of the equipment; in the system start up and testing it shall be in the same operating condition as when it left the factory, and no problems should be found.

There are occasions when a test will show bad insulation like a faulty transformer winding or a missing interlock in a control scheme that would have resulted in catastrophic failure if the system had been energized. In such a case, the technical manual indicates that there are specific procedures which should be performed for each commissioning test referring to the equipment to be used and are called Systems Operation Documents (SOD). The work items and schedule will depend on many items including the importance and cost of the equipment, consequences of failure, maintenance availability, environmental conditions, and safety requirements.

3.2.5 Final acceptance

As-built documentation:

Before the actual process of construction commences, it is the responsibility of the contractor to submit the initial basic engineering designs of the potential systems. The designs are then reviewed by the engineering group. The basic designs are further transformed into detailed engineering designs, which will be used by the contractor during the procurement, manufacture and installation of system processes. The as-built documents are the contractor's delivery of final documentation.

When the project is finalized it is the responsibility of the contractor to provide the client with all the final documents, including all modifications done during the installation phase, commissioning and start-up; this information is known as the as-built documentation. Common documentation for protection systems include the following: operational instructions, maintenance instructions, preventive maintenance schedule, training documents, bill of materials, spare parts catalogues, catalogues and manuals for all of the equipment used, and configuration and testing documents.

Manuals of all hardware and software used and protection relay programmes and database listings are also needed. In addition, programme development manuals for the protection relay system, a copy of all the software, a list of all test certificates and reports, a list of all delivery documents, and a certificate of conformity for all equipment should also be included.

Warranty period:

Generally, within the specifications for power plant projects it is common that the warranty periods for the equipment last for months of operation after the date at which commercial operation commences. The warranty for the potential system equipment requires the following: that it be free from defects in design, materials and workmanship. The warranty period is taken into account in the process of technical and economic evaluation. During the contract negotiations, the warranty period and what is included in the warranty is decided.

4. ELECTRICAL PROTECTION FOCUS IN RELAY TECHNOLOGIES

4.1 Fundamentals

The main function of an electrical protection system is to detect and isolate faults occurring in the power system. Similarly, it needs to keep the power system stable by isolating only the components that are under fault, while leaving as much of the network as possible still in operation. Electrical protection systems in geothermal power plants usually comprise the following five main items:

1. Current and voltage transformers: to step down the high voltages and currents of the electrical power system to convenient levels for the relays to deal with.
2. Relays to sense the fault and initiate a trip or disconnection order.
3. Circuit breakers: to open/close the system, generally located so that each generator, transformer, bus and feeder can be disconnected from the rest of the system.
4. Batteries to provide power in case of a power disconnection in the system.
5. Communication channels to allow an analysis of the current and voltage at remote terminals of a line and to allow remote tripping of equipment.

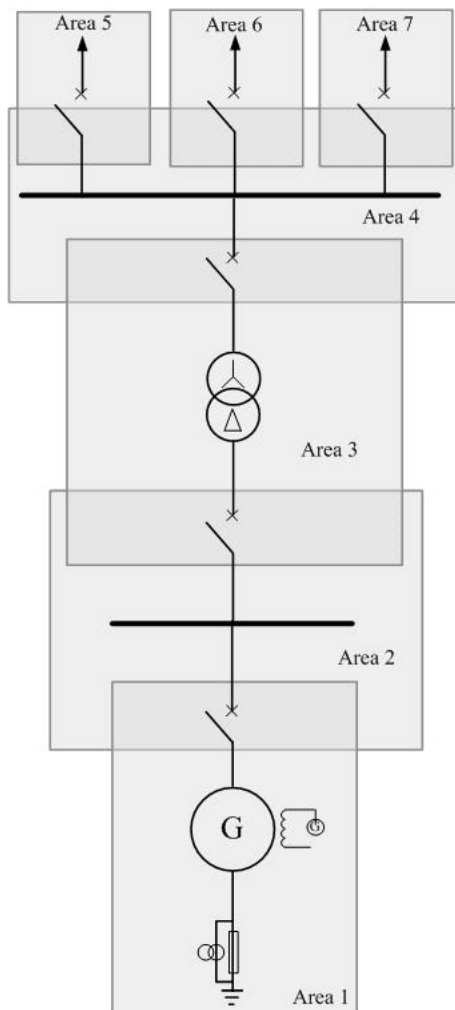

FIGURE 9: Protection areas in a power system

It can be stated that the protective relays are the brains of the protection system. To facilitate the rapid removal of a disturbance from a power system, the system is divided into protection areas (Figure 9). Relays monitor the system quantities (current, voltage) appearing in these areas; if a fault occurs inside the area, the relays operate to isolate the area from the remainder of the power system.

For simplicity on one-lines, the function is usually identified by what is referred to as an ANSI device number, and therefore, there are three terms (element, function, device number) in use for approximately the same concept. In the era of electromechanical and solid state relays, any one relay can implement only one or two protective elements/functions, so a complete protection system may have many relays on its panel. This report focuses on the new generation of protective relays: the digital numeric relay, where many functions can be implemented by the microprocessor programming. That means that in one digital relay the implementation of one or all of these device functions can be performed.

Digital relay technology provides an economically viable alternative for the protection of the inertia. In addition, digital technology provides several other advantages which include: improved performance, greater flexibility, reduced panel space and wiring, metering of various parameters, event reporting, fault data recording, remote communication, continuous self-checking and self-calibration.

The typical structural design of protective relays is shown in Figure 10. Protective relays use an advanced microprocessor to analyze power system voltages and currents for the purpose of detecting faults in an electrical power system. It consists of one or more microprocessors, digital and analogue inputs/outputs, digital or optical communication ports and a

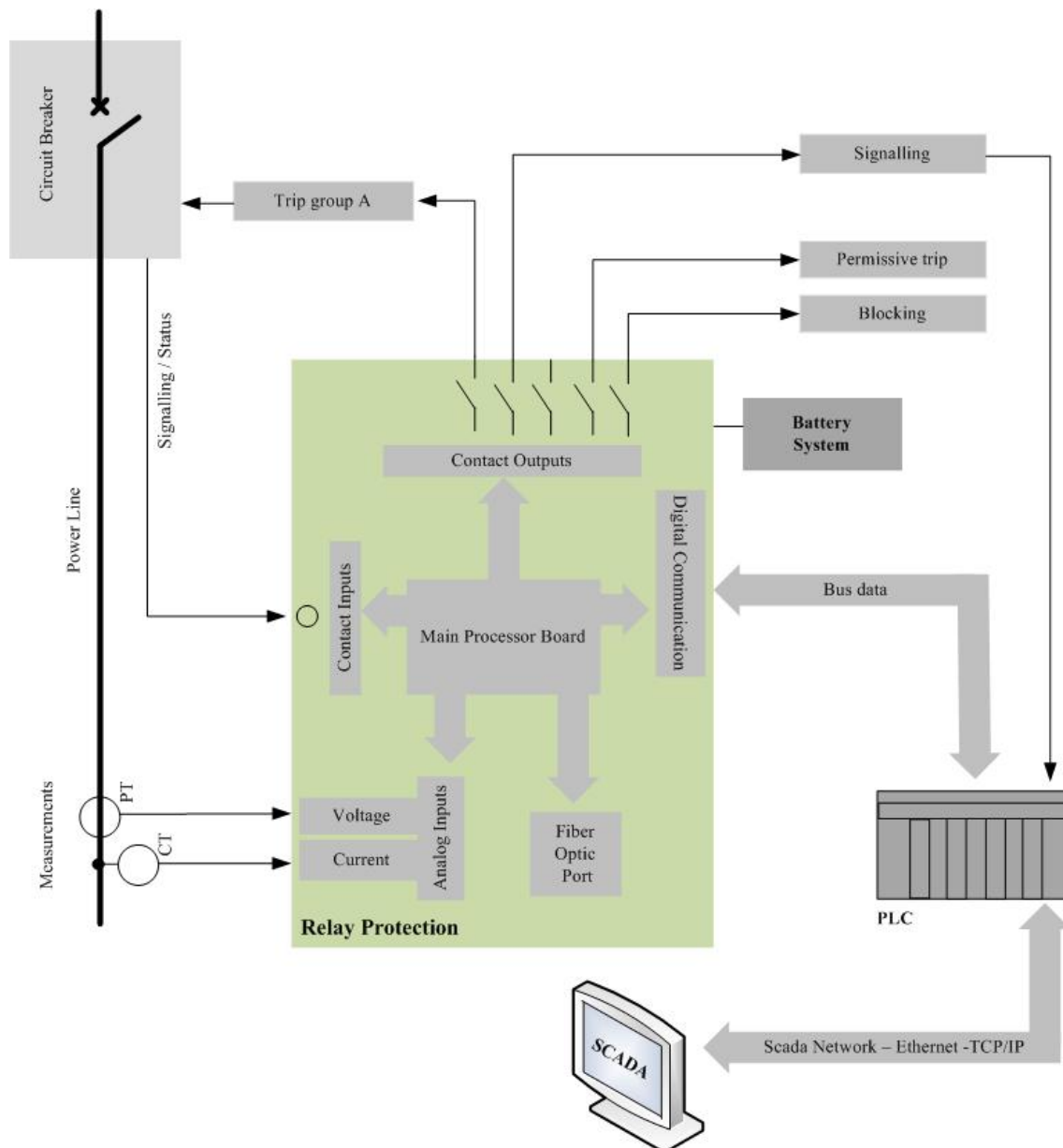

FIGURE 10: Typical structural design of a relay protection system

power supply. The analogue signals are normally converted to digital form, for processing in software. Finally, digital outputs are used to send signals to other devices that perform actions such as tripping, blocking, and signalling, etc.

The protective relay can perform several functions that can be utilized for protecting electrical equipment such as the generator, the transformer or the motors. In the following section some of the aforementioned functions will be touched upon in greater detail.

4.3 Protection schemes in geothermal power plants

The description of this protection schematic is based on the Berlin and Hellisheidi protection systems (Reykjavik Energy, 2004). These systems are completely independent of the functions and control modes of the control systems. The protection system is active although the computer based control systems are not active and the respective equipment is operated in a local control mode. The protection relays used in these power plants for the electrical protection are modern numerical

microprocessor-based relays. The relays have a serial connection for remote settings and indication of settings, measured values, event registers and disturbance records. For convenience, the trip groups have been divided into trip types to be able to define which piece of equipment the relevant protection functions will trip. These protection systems must trip different circuit breakers depending on the nature of the fault. Its number is largely dependent on the plant configuration. A typical trip group function for a geothermal power plant is shown in Table 8.

TABLE 8: Typical trip groups for a geothermal power plant

Action	Trip						
	Type 1	Type 2	Type 3	Type 4	Type 5	Type 6	Type 7
Trip generator circuit breaker	•	•	•	•			
Trip field circuit breaker	•	•	•				
Trip turbine	•	•					
Trip all circuit breakers at the HV and MV side of the unit transformer	•						
Unit start block.	•	•					
Lock-out HV circuit breakers	•						
Lock-out MV circuit breakers	•						
Trip respective MV circuit breaker					•		
Trip all circuit breakers in the switchgear						•	
Lock-out of all circuit breakers						•	
Trip respective HV side and LV side circuit breaker							•

The functions of protection relays are generally divided into two groups for the purpose of redundancy. Each group function is executed by a number of relay protections. For the detection of a certain fault it is possible that several functions of protection exist. These groups are known as: primary protection and back-up protection. Each group is assigned function protections, which work to detect the same faults within in the group, utilizing different methods. This ensures that the failure of a single component is managed, and does not lead to the total break-down of the system. Two strategies of redundancy are commonly used, partial and complete. In a partial redundancy at least two protection devices are employed and the protection devices are, for example, connected to the same instrument transformer. The complete redundancy starts with separate instrument transformers, and then continues with the protection devices and the trip signal, which is routed via separate auxiliary supplies to the circuit breaker, utilising two trip coils.

The digital relays provide certain advantages, as they are usually programmed to execute the same functions on both relays; and this extra service is provided without adding any additional cost. Back up protection is also recommended to protect the main equipment in the power plant from the effects of faults that are not cleared because of failures within the normal protection scheme. The backup relaying can be applied to provide protection in the event of a failure at the power plant, on the transmission system or both (Reimert, 2006).

4.3.1 Generator

The generator is one of the most expensive pieces of equipment to be found in the power plant, and therefore the electrical faults have to be identified and cleared in due time. Damages caused by such faults are often very costly due to the generator ceasing operation, and the length of the repair period resulting in a loss of sale of energy for the power plant. The objective of this section is to give an overview of the generator protection schematic (Figure 11). The IEEE guidelines are recommended for a detailed application (IEEE, 1995). In Table 9, below, a group of functions that are generally used in the protection of generators is presented.

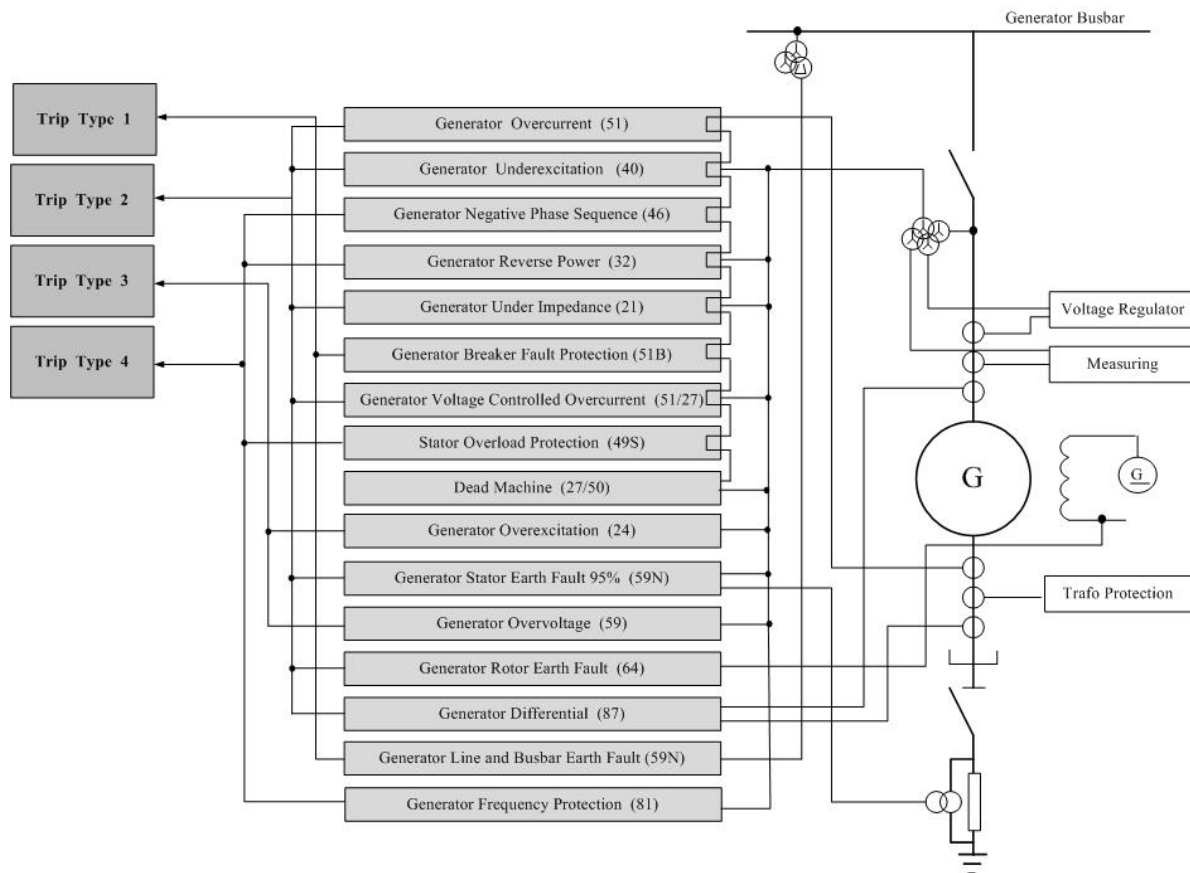

FIGURE 11: Typical generator protection scheme

TABLE 9: Generator function groups

Group 1		Group 2	
Function	ANSI number	Function	ANSI number
Generator differential protection	87G	Generator under impedance protection	21
Generator voltage controlled overcurrent protection	51V	Generator stator earth fault 95% protection	59N
Generator rotor earth fault protection	64R	Generator overvoltage protection	59
Generator overexcitation protection	24	Generator negative phase sequence protection	46
Generator reverse power protection	32R	Generator overcurrent protection	50/51
Generator stator overload protection	49	Generator underexcitation protection	40
Generator line and busbar earth fault protection	59N	Frequency protection	81

The faults which generally occur in generators can be classified into the following:

Phase faults:

Phase faults in a generator stator winding can cause thermal damage to the insulation, the windings, the core, and mechanical torsion shock to the shaft and couplings. Trapped flux within the machine can cause fault current to flow for many seconds after the generator is tripped and the field is disconnected.

For phase to phase faults, a differential protection (87G) is normally applied to generators as the

primary protection. Generally the types of faults detected by this function are: phase to phase, three-phase, and double-phase to ground faults.

Back-up protection can be used in the following functions which, if used alone, would not be able to provide the protection necessary for the variety of phase faults: the unit-connected differential relay (87U), the under impedance relay (21), the voltage controlled overcurrent relay (51V) and the negative phase sequence overcurrent function (46).

Ground faults:

Earth fault protection must be applied where impedance earthing is employed in order to reduce the current level of the phase to ground faults. As is mentioned in the IEEE guide for AC generator protection: the differential relaying will not provide ground fault protection on high-impedance-grounded machines where primary fault current levels are limited to 3-25 A. The type of protection required will depend on the method of earthing and the connection of the generator to the power system.

For low impedance grounded generators, the phase differential protection (87) can be used as primary protection, if the magnitude of the fault and the sensitivity of the relay are considered. For generators with high impedance, a distribution transformer is used with a resistor connected across the secondary winding. If a low pickup overvoltage relay (59N) is used, it is connected across the secondary grounding transformer. This function detects faults to within 5-10% of the stator neutral (90-95% of the stator winding). The relay must be insensitive to the third-harmonic voltage that may be present between neutral and ground. Determination of the third-harmonic voltage at neutral (27TN) is sometimes used in order to cover 100% of the stator winding, when the faults are very close to the generator neutral.

Loss of excitation:

A loss of field occurs when the excitation to the generator field winding fails. When excitation is lost, the rotor current decays at a rate determined by the field circuit time constant. The internal generator voltage will decay at the same rate. Because the generator reactive power output is proportional to the internal generator voltage, the reactive output also decreases. If the generator is initially supplying reactives to the power systems, then the reactive output will decrease down to zero as the generator draws increasing reactive from the power system to replace excitation formerly provided by the field circuit. The reactive consumption can exceed the generator MVA rating (Reimert, 2006).

The loss of excitation protection (40) function is a backup for the proper operation of the excitation system. In case of loss of excitation, the terminal voltage will begin to decrease and the stator current will increase, resulting in a decrease of impedance viewed from the generator terminals and will also cause a change in the power factor.

A two-element offset mho relay is used to protect against field loss. The relay is supplied with the generator terminal voltages and currents and is normally associated with a definitive time delay. Digital relays use the positive sequence voltage and current to evaluate the positive sequence impedance as seen at the generator terminal (Benmouyal, 2007).

Over excitation:

IEEE standard limits are 1.05 pu (generator base) for the ratio of the voltage to frequency (V/Hz) for generators. They establish that when voltage exceeds this ratio, then the saturation of the magnetic core of the generator or the connected transformer can occur and stray flux can be induced in non-laminated components. This danger can occur during: the start-up process, a full load disconnection, "weak" systems, and island operation, etc. This is not designed to carry flux and can in turn cause excessive interlaminar voltages between laminations at the ends of the core. The field current in the generator could also be excessive. This can cause severe overheating in the generator or transformer and eventual breakdown in the insulation.

The V/Hz (overexcitation) relay (24) measures both the voltage magnitude and the frequency over a broad range of frequencies. An over voltage (59) relay function can be used for a partial backup.

Unbalanced currents:

In some cases the currents can become imbalanced in the stator causing its subsequent production of negative phase sequence currents. This will be the cause of double frequency currents on the surface of the rotor. That, in turn, may cause excessive overheating of the rotor and trigger substantial thermal and mechanical damages (Benmouyal, 2007).

A negative phase sequence over current function (46) is provided to protect the unit before the specific limit for the machine is reached.

4.3.2 Transformer

The power transformer is a major and important piece of equipment in geothermal power plants. Considerations for transformer protection functions vary with the application, size and importance of the transformer. The objective of this section is to give an overview of the schematic of the generator unit transformer. In Figure 12, the unit transformer is connected to the grid system (substation) via a HV cable. The IEEE guides for a detailed application are recommended (IEEE, 2000). Below a group of functions (Table 10) that are generally used in the protection of transformers is presented.

The types of faults found in transformers can be placed into two main groups, external and internal faults. For external faults, the transformer is tripped if other protective devices detect faults. Time graded overcurrent relays are employed as a back-up protection. Also, in case of sustained overload conditions, thermal relays are used to detect overload conditions and to sound an alarm.

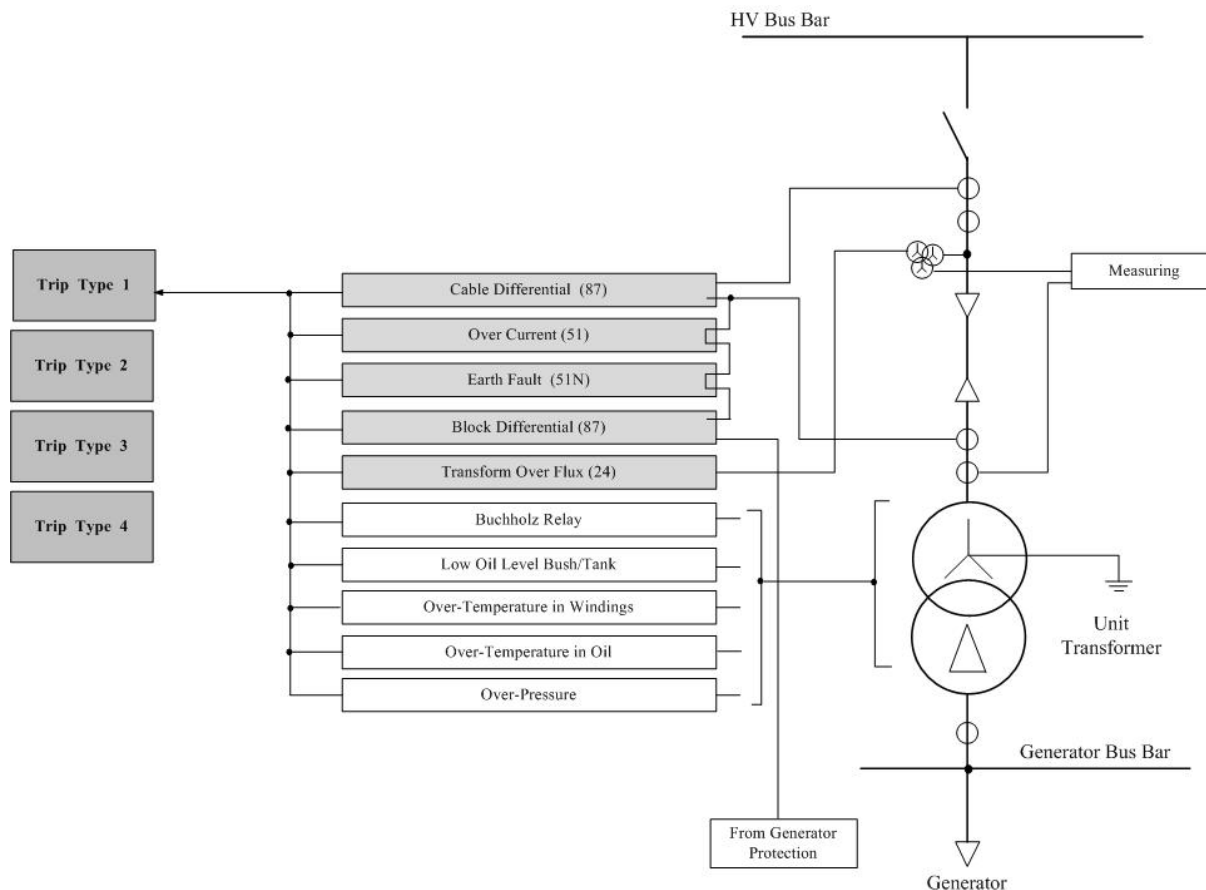

FIGURE 12: A typical transformer scheme protection

TABLE 10: Transformer function groups

Group 1		Group 2	
Function	ANSI number	Function	ANSI number
Transformer overcurrent protection	50 - 51 T	Generator-unit transformer block differential protection	87
Transformer earth fault protection	50 - 51TN	HV cable differential protection	87
Transformer over-excitation protection	24T		
HV cable overcurrent protection	50		
HV cable earth fault protection	51N		

The primary transformer protection is for internal faults, and can be divided into groups: short circuits in the transformer winding and connections, and incipient faults. Short circuit faults include: phase to phase, phase to ground and interturn faults on windings. Incipient faults include: poor electrical connections, core faults, and the failure of the coolant.

Phase faults:

Statistics show that winding failures most frequently cause transformer faults (IEEE, 2000). Insulation deterioration is a major reason for winding failure. The main reasons for phase faults are certain forces that can cause the deterioration and failure of the winding electrical insulation. These forces are the result of the expansion and contraction of materials due to thermal cycling, vibration, and local heating. This is due to magnetic flux impact forces through fault current and excessive heating which can cause overloading or inadequate cooling.

The transformer overcurrent protection function (50-51T) is used to detect the fault current that is the result of insulation damage which, in turn, can result in the following types of faults: primary winding phase-phase and phase-earth faults. The transformer earth fault protection function (50-51TN) uses overcurrent elements to provide adequate protection for the transformer windings. This is especially the case for a star-connected winding with an impedance-earthed neutral.

The current differential function (87) is the most common function used for transformer protection, as it is able to detect a variety of faults: primary winding phase-phase and phase-earth faults, secondary winding phase-phase and phase-earth faults, interturn faults, core faults and tank faults. The differential function comprises a number of additional functions, e.g. having to match the transformer ratio and vector group and to restrain against inrush currents and overexcitation. In big and important power plants they are used to both “block differential” to cover both the transformer and the generator, and “transformer differential” but only to cover the individual transformer.

Overfluxing:

The transformer can also be damaged due to overvoltage and underfrequency operation outside their design limits. The transformer operates close to the knee of the saturation curve, therefore even a small increase in voltage results in a very large increase in excitation current. When the V/Hz ratio is exceeded then the saturation of the magnetic core of the transformer occurs. This causes excessive core flux resulting in a high interlamination core voltage which, in turn, results in iron burning (Mozina, 2009).

In some cases the transformer over-excitation protection (24T) is provided by the generator overexcitation protection, which uses the voltage transformer connected to the generator terminals.

Overheating:

The rating of a transformer is based on the temperature rise above an assumed maximum ambient temperature. Sustained overload is not allowed if the ambient temperature is equal to the assumed

ambient temperature. At a lower ambient temperature some degree of sustained overload can be safely applied.

In thermal image techniques a temperature device is placed in the transformer oil near the top of the transformer tank. Protection is arranged to trip the transformer if an excessive temperature is reached. The trip signal is usually routed via digital input of a protection relay on one side of the transformer, with both alarm and trip facilitating made available through programmable logic in the relay.

Incipient:

To detect incipient faults a gas actuated relay (Buchholz relay) is used. These faults are initially minor faults but may cause major faults over time. Failures of the winding insulation will result in some form of arcing, which can decompose the oil into hydrogen, acetylene, methane, etc. Severe arcing will cause a rapid release of a large volume of gas as well as oil vapour. The action can be so violent that the built up pressure can cause an oil surge from the tank to the conservator; the mechanical relay can detect both gas and oil surges as it is mounted in the pipe to the conservator (Hewitson et al., 2004).

The Buchholz relay will, therefore, sound an alarm for the following fault conditions, all of which are of a low order of urgency: hot spots on the core due to a short circuit of lamination insulation, core bolt insulation failure, faulty joints, interturn faults, or other winding faults involving only lower power infeed loss of oil due to leakage.

These types of faults in transformers cannot be detected using electrical detection schemes, as mechanical devices are used which are commonly linked to the digital or analogue inputs of the protection relays. Table 11 shows the mechanical protections that are usually required for a transformer unit.

TABLE 11: Mechanical transformer protection groups

Group 1 - function	Group 2 - function
Transformer Buchholz relay	Overpressure
Overtemperature in LV windings of the transformer oil dial type thermometer	Low oil level in unit transformer
Overtemperature in oil of the transformer oil dial type thermometer	Overtemperature in HV windings unit transformer oil dial thermometer
Low oil level in high voltage cable terminations	Fault in tap changer

4.3.3 Motor

Circulation pumps are essential in the process of producing geothermal power. It is important to protect the motors of circulation pumps (Figure 13). The motors commonly used for this function are large, however, the same basic principles apply to them as with small motors that are used. The IEEE guidelines for a detailed application are recommended; presented aside are a group of functions that are generally used in the protection of motors (Table 12).

Short-circuit:

Motor short-circuit protection (50) is often provided to cater for major stator winding faults and terminal flashovers. Because of the relatively greater amount of insulation between phase windings, faults between phases seldom occur.

TABLE 12: Motor function groups

Group	
Function	ANSI number
Motor thermal overload	49
Motor locked rotor	51LR
Motor short circuit	50
Motor unbalance	46
Motor earth ground fault	51N

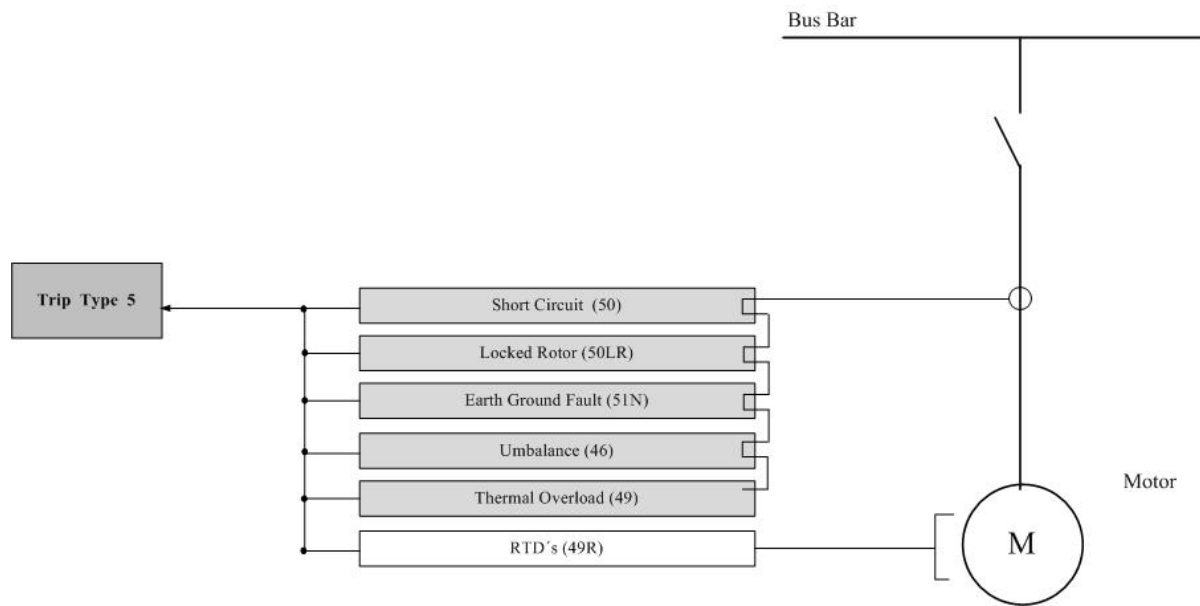

FIGURE 13: Typical motor scheme protection

For essential-service motors, the inverse-time phase overcurrent relays are usually omitted. Instead, instantaneous phase relays (50), inverse-time and instantaneous ground relays (51N/50N) or differential relays are used (87). The reason for the omission is to trip the motor breaker automatically only for short circuits and not for any other reason (Mason, 2009).

This is because tripping such a circulation pump means a decrease in power generation. In the Berlin power plant, for example, the units have two circulation pumps in the circulation process; when one pump is tripped, the power decreases by approximately 50%.

Stator overheating:

Power plant maintenance personal agree that excessive heat causes a rapid deterioration of motor winding insulation. This can be directly caused by overloading, operation on an unbalanced supply voltage, or single phasing, all leading to excessive heating that leads to the deterioration of the winding insulation until an electrical fault occurs.

There are two main classes of overtemperature thermal protective devices (49). One is a line break type, which interrupts load current directly. The second is a control circuit system using detector devices, which interrupts the motor current through its controller. Current sensing alone cannot detect some conditions, such as restricted ventilation. Temperature sensing alone may be inadequate, for example, with frequent starting or jogging. For some conditions, a coordinated arrangement of current and temperature sensing may be required.

Stalled rotor:

Motors have three modes of operation: locked rotor or stalled, acceleration, and running. During a failure to start or accelerate after being energized, a motor is subject to extreme heating in both the stator windings and rotor. It is not, therefore, possible to distinguish between a stall condition and a healthy start solely on the basis of the current drawn. Discrimination between the two conditions must be made based on the duration of the current drawn (AREVA, 2002).

The protective relay is able to distinguish between the three modes of operation, based on the current curves of the motors. A locked rotor (51LR) function is very common on this protection scheme against stalled rotor conditions.

4.4 Special considerations for the generator protective relay in geothermal power plants

There are a variety of functions which can be seen in generator protection, many of which are calculated based on electrical properties. However, there are functions which are linked to the type of process and turbine used.

4.4.1 Antimotoring

Monitoring of a generator is done when the energy supply to the prime mover is shut down and the generator is still in the network at a synchronous speed with the field that normally exists. After this scenario, as indicated in the technical literature and standards, the power flows from the system to the generator, and this acts as a synchronous motor and drives the prime mover. If it is driven as an induction motor, negative sequence currents will be established in the rotor, potentially damaging damper windings, wedges, retaining rings and forging. Further, this condition will affect the prime mover. In geothermal power plants the energy supply is composed of steam and the prime mover, i.e. the steam turbine. These types of turbines are the most sensitive to motoring and that is the reason why the protection schemes work differently in this particularly case.

The steam turbines could overheat because there is insufficient steam flow from the cooling effect provided by the steam, as this also provides the energy for rotating the rotor and removing the heat from parts of the turbine. The condensing turbines operate under a vacuum in the exhaust (Figure 2) and can withstand motoring longer than the backpressure turbines. Windage loss causes significant heating of the turbine blades causing damage to them and possibly to the gearbox as well.

The length of time that a steam turbine can be operated in motoring conditions aids in establishing its maximum time. The maximum time for the operation of a steam turbine will vary depending on the turbine design. Such important information must be requested from the manufacturer, as they can determine the sensitivity setting in the relay.

Reverse-power protection

The reverse-power relay (32) is used to monitor the electrical condition when the turbine energy input to a generator is removed. The primary indicator of motoring is the flow of real power into the generator acting as a synchronous motor. The reverse-power relay detects the reverse flow of power that would occur should the prime mover lose its input energy. Depending on the type of prime mover, the magnitude of the motoring power varies considerably. For steam turbines operating at full vacuum and zero steam input, motoring will draw 0.5-3.0% of the unit rating (Benmouyal, 2007).

Reverse-power produced in steam turbines is susceptible to an operation failure if the Volt-Ampere reactive loading is high during motoring. This is due to the low motoring power required by these units and errors in the measurement of the high power factor angle (Reimert, 2006).

For example, in unit 1-2 in the Berlin power plant in El Salvador, a multifunction protective relay SEL-300G was installed for the generator. The anti motoring protection in the SEL-300G is provided by a reverse/low-forward power element. This element measures the real-power flow from the generator. If the generator's real-power output drops below the element's threshold, the relay asserts the relay word bit associated with the instantaneous threshold and starts the element's definite timer (SEL, 2009).

The SEL-300G multifunction protection relay includes two reversed power functions calibrated in per unit Watts. One of the functions is for motoring protection and the second function can be incorporated in the sequential trip. The relay delay of the tripping has to be taken into account in the settings to allow the unit to synchronize and to load above the relay setting to avoid tripping during start up.

Sequential trip

Reverse-power function is related in the majority of cases to the sequential trip logic. The main reason for a sequential trip is to minimize the possibility of damaging the steam turbine as a result of an over speed

situation when the generator breaker is tripped. In this logic scheme (Figure 14) the reverse relay in the series with the mechanical fault signal indicates that the turbine has been tripped, providing security for a possible over speed. This condition could be more harmful for the turbine-generator than a quick motoring of the unit. This will ensure that steam flows have been reduced below the amount necessary to create unnecessary risk of over speeding. The sequential trip is used in normal shutdown and tripping for prime mover problems. Also, there are other methods for tripping the generator breaker or shutting down the steam supply when the abnormal situation detected has to isolate the generator or turbine unit rapidly. Those methods are known as the simultaneous trip, the generator trip, and the unit separation trip.

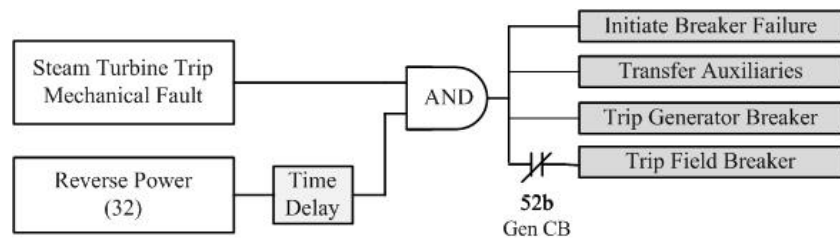

FIGURE 14: Sequential trip logic scheme

In the design of a sequential trip it is necessary to take into account the recommendations of the manufacturer and reference information (IEEE, 1995). A case can occur when the turbine is operating with the valve partially closed, and slightly less than the no-load value. The electrical input from the system could be essentially zero, and the reverse power relay would not detect the condition.

4.4.2 Resonance

Steam turbines are more adversely affected by off-frequency operation than the generators they drive. A key feature of turbine blade design is assuring that the blades are not damaged by mechanical resonance. Mechanical resonance produces high vibratory stress that can cause fatigue cracking and eventual blade failure. Resonance occurs when the natural frequency of a blade coincides with the vibratory stimuli. The steam flow path is not homogeneous. Physical irregularities in the flow path produce turbulence that appears as a cyclic force to the blades (Reimert, 2006).

The turbine manufacturer provides guidance and information of impact during a multiple frequency band event and how to determine an appropriate protection strategy. The values of the frequency and time of operation for the proper operation of the turbine is provided in the information from the manufacturer. In the manufacturer's information the following bands of operation are defined: prohibited, restricted time and continuous. The protective scheme must operate with sufficient speed to provide protection for each band according to the manufacturer's characteristics.

Abnormal frequency protection

The governor fitted to the steam turbine normally provides protection against overfrequency. For this reason, it is most important to incorporate an under-frequency function to the protection scheme. In certain cases, an overfrequency relay may be suitable for providing both of these forms of protection.

Under-frequency may be a result of an overload of generators operating on an isolated system, or a serious fault on the power system that results in a deficit of generation compared to the load. Automatic load shedding programmes on transmission power systems provide the initial under-frequency protection.

For example, in El Salvador, the operator of the transmission system (UT) states that: the load shedding schemes for low frequency in the network will be implemented according to the requirements determined by the development studies and coordinated by the UT with the individual generators connected to the grid. The range variation that is chosen for this scheme should be updated

depending on the needs of the network and its evolution over time must be periodically reviewed at least once a year. Load shedding is designed to trip enough load to restore the load/generation balance and thus correct the under-frequency condition.

Steam turbines may, however, have to be protected against excessively low frequency by the tripping of the generators concerned. If the generator frequency varies from nominal, islanding is declared and either the generator is tripped or the point of common coupling with the utility is opened.

5. COMMISSIONING OF RELAYS

The realization of tests begins with individual tests of each force that is part of the protection system. However, the appropriate commissioning of the protection system requires testing of the complete system. This process is considered in the site development, as all equipment has been through the routine tests in the factory. The commissioning tests give the guarantee that all equipment is in order and working properly, was not damaged, and was installed correctly.

TABLE 13: Commissioning relay activities

Commissioning activities
Wiring diagram check
General inspection of the equipment
Insulation resistance measurement of all circuits
Perform relay self-test procedure
External communications
Test main current transformers
Test main voltage transformers
Check protection relay alarm/trip settings
Check tripping and alarm circuit
Secondary injection test on relays
Primary injection tests on relays
Testing of protection scheme logic

Table 13 displays the basic commissioning activities and was prepared based on the Network Protection and Automation Guide (AREVA, 2002). Each step ensures an effective and smooth running of the protection system. In order to initiate this commission, the following information should be collected: single-line diagrams, three-line diagrams, circuit diagrams, test switches, schematic drawings, settings, manuals and coordination studies.

Wiring diagrams are checked, and within these diagrams the interconnection reference numbers must be displayed. Once the diagrams are reviewed they can be sent for a general inspection of the equipment, e.g. checking all connections, wires on relay terminals, labels on terminal boards, the voltage and current supplied to the relays are checked and compared with the name plate or instruction book. The measurement of insulation resistance is a common routine test performed on all types of electrical wires and cables. The results obtained are not intended to be useful in finding localized defects in the insulation as in a true hipot test, but rather give information on the quality of the bulk material used as the insulation.

Before energizing the main circuits, some tests in the current transformer and voltage transformer have to be done: a polarity check and an accuracy test. This procedure checks the polarity between the primary and secondary winding and guarantees the correct direction of energy flow. The polarity check takes place before the accuracy test. The test compares the ratio error of the current or voltage transformer under test with a standard transformer. The results are compared with the error values corresponding to the accuracy class. To finalize the testing of the voltage transformers a phasing check is done.

In primary injection testing the entire chain of the current transformer, conductors, connection points, the relay protection and the circuit breaker are covered by the test. A high current is injected into the primary side of the current transformer.

The protection relay alarm and trip settings are required to be entered and checked. The data settings should be obtained as calculated from the protection setting study.

The perform relay self-test procedure is detailed in the manual in order to determine if the relay is operating correctly. These electrical tests and adjustments include: the contact function test, closing or opening the contacts and observing that they perform their required function such as trip or block; the pickup test, gradually apply current or voltage to see that the pickup is within limits; and the dropout test, to check excess friction and to reduce the current until the relay drops out or resets. A good set of testing equipment and relay tools are important. Several manufacturers produce portable relay test sets.

Secondary injection is used to test the functionality of each relay, e.g. each of the protection functions used and to be sure it is operating properly according to the settings. For this type of testing, test switches on the relay panel are used in order to facilitate testing. The output contact has to be monitored to confirm proper operation. Secondary injection test sets are computer based and designed to cover the entire commissioning test. In the primary injection testing the entire chain of the current transformer, conductors, connection points, the relay protection and the circuit breakers are covered by the test. A high current is injected into the primary side of the current transformer. Secondary injection tests are always done prior to the primary injection tests. This is because the risks during the initial testing to the LV side of the equipment under testing are minimised. The primary (HV) side of the equipment is disconnected, so that no damage can occur.

6. CONCLUSIONS

The planning process is vital for the successful development of a geothermal power plant project. In order to fully define the plan of the project it is necessary to understand the detailed process of the implementation of the numerous systems that comprise a power plant. In the case of the power systems, it is proposed that each technical area of the project can be divided into five stages of development: feasibility study, design, procurement, construction and start up, and final acceptance. Each stage should be meticulously itemized: corresponding activities, delivered documents, estimation of resources, time and the interrelation between activities of other systems.

The electrical protection system has a fundamental role in the reliability and security of the operation of a geothermal power plant. The protective relay is the control device of the protection system. Its main responsibility is to avoid the destruction of the interconnected equipment, which will impede the procurement of electrical energy. The system protection will isolate the faulty area in order to avoid the suspension of the generation of energy.

In order to obtain high levels of availability in the operation of a geothermal power plant, special attention should be given to the protection scheme of the main equipment. The generator, transformer, and circulation and vacuum pumps are defined as the main equipment. The main equipment protection scheme should be designed with a backup. This is due to their high cost and lengthy installment; if they were ever to fail, it would cause the plant to become inactive for a long period of time.

One of the most important aspects of the protection system of a geothermal power plant is the correct tripping actions of the generator protection relays. This requires an understanding of the technical characteristics of the steam turbine, the capacity of the system generator/turbine, the operation of the unit, and the geothermal process of energy conversion. The proposal of the selection of the type of trip should minimize the loss conditions of the process, and permit the rapid return of the unit to the grid.

ACKNOWLEDGEMENTS

I would like to express my gratitude to the United Nations University Geothermal Training Programme and my employer, LaGeo S.A. de C.V. for giving me the opportunity to take part in the six months Geothermal Training Programme in Iceland. Special thanks go to Dr. Ingvar B. Fridleifsson, Director of the UNU-GTP and Mr. Lúdvík S. Georgsson, Deputy Director, for their encouragement and patience throughout the duration of this training, and for the enthusiastic work of the staff: Ms. Thórhildur Ísberg, Mr. Dorthe Holm and Mr. Markús A.G. Wilde. I would like to express profound gratitude to my supervisor, Mr. Ármann Ingason, for his support, encouragement, supervision and useful suggestions throughout this report.

My gratitude to the people who gave me their invaluable support throughout this training: Mr. Jorge Burgos, Mr. Ricardo Escobar, Mr. José Luis Henríquez, Mr. Roberto Rivera, Mr. Alberto Amaya, Ms. Rosa Escobar, Ms. Claudia Sigüenza, Mr. Obdulio Calvo, Mr. Manuel Rivera and Mr. Danilo Cea.

REFERENCES

- AREVA, 2002: *Network protection and automation guide* (1st edition). AREVA, Paris, France, 500 pp.
- Benmouyal G., 2007: The protection of synchronous generators. In: Grigsby L. (editor), *Power system stability and control*. Taylor & Francis Group, US, 276 pp.
- Dipippo, R., 2008: *Geothermal power plants. Principles, applications, case studies and environmental impact*. Elsevier Ltd., Kidlington, UK, 493 pp.
- Hewitson, L., Brown, M., Balakrishnan, R., 2004: *Practical power systems protection*. Elsevier Ltd., UK, 277 pp.
- Reykjavik Energy, 2004: *Hellisheidi geothermal power plant, control and protection system*. Reykjavik Energy, Contract documents, Volume 1/2.
- SEL, 2009: *Instruction manual SEL-300G, Multifunction generator relay*. Schweitzer Engineering Laboratories, Inc., website: www.selinc.com.
- SIGET, 2008: *Bulletin of electrical statistics*. SIGET, San Salvador.
- IEEE, 1995: *IEEE guide for AC generator protection*. IEEE standard C37.102-1995.
- IEEE, 2000: *IEEE guide for protective relay applications to power transformers*. IEEE standard C37.91-2000.
- Mason R., 2009: *The art and science of protective relaying*. General Electric Company, website: www.gedigitalenergy.com.
- Mozina C., 2009: *Digital transformer protection from power plants to distribution substation*. Beckwith Electric Company, website: www.beckwithelectric.com.
- Reimert D., 2006: *Protective relaying for power generation systems*. Taylor & Francis Group, US, 563 pp.
- U.S. Army Corps of Engineers, 1994: *Hydroelectric power plants electrical design*. USACE, Engineer manual 1110-2-3006, website: www.usace.army.mil.