



# **GEOHERMAL POWER PLANTS FOR MEDIUM AND HIGH TEMPERATURE STEAM AND AN OVERVIEW OF WELLHEAD POWER PLANTS**

**Gideon Gitonga**

Kenya Electricity Generating Company Ltd.

Naivasha

KENYA

*ggitonga@kengen.co.ke*

## **ABSTRACT**

Geothermal energy is a renewable energy source with different applications depending of the actual characteristics of the resource. Utilization of geothermal resources is largely dependent on the resource temperatures. High temperature geothermal resources are commonly used for power generation by conventional geothermal power plants. Medium temperature geothermal resources are used for power generation through binary power plants. Low temperature geothermal resources are commonly used for direct applications such as heating and recreation.

## **1. INTRODUCTION**

Geothermal energy refers to the heat energy that emanates from beneath the earth's crust. Geothermal projects follow a carefully crafted exploration and development program. The scientific exploration methods quickly and at moderate cost assess vast potential areas that are then studied in detail followed by drilling to confirm the resource. After drilling of geothermal wells, they have to be subjected to a series of tests to determine their potential outputs and the nature of the reservoir that the well has intercepted. By testing the potential outputs of the well, the kind of utilization suitable for the well can be determined. High temperature resources ( $> 200^{\circ}\text{C}$ ) are suitable for high temperature geothermal power plants. Medium temperature resources ( $>100^{\circ}\text{C} <200^{\circ}\text{C}$ ) are suitable for binary power plants. Low temperature geothermal resources ( $< 100^{\circ}\text{C}$ ) are suitable for direct uses (recreation, heating and drying).

High temperature geothermal power plants are energy converters that convert high temperature geothermal energy to electricity. The power plants use steam turbines to convert the heat and pressure energies in the steam to mechanical energy. The generators then convert the mechanical energy to electrical energy.

This paper discusses the type of high temperature geothermal power plants and their process description and systems. The paper also presents wellhead generation concept as a type of high temperature geothermal power plant.

## 2. DEVELOPMENT PLANNING AND DECISION MAKING

After confirmation of the potential of the well or group of wells through discharge tests, the field developer will have to decide and plan for its utilization. Utilization of a geothermal resource is mainly dependent on the temperature of the resource. High temperature resources (> 200°C) are commonly used for high temperature geothermal power plants. Medium temperature resources (>100°C < 200°C) are commonly used for Binary power production and industrial uses. Lower temperature resources are commonly used for direct uses (Geothermal Education Office, 2011). Direct use processes include, swimming, bathing, space heating and cooling, agricultural applications, aquaculture applications and lately industrial processes like mineral extraction among others.

The Lándal diagram shown in Figure 1 provides a guideline to potential uses of geothermal resources based on resource temperatures.

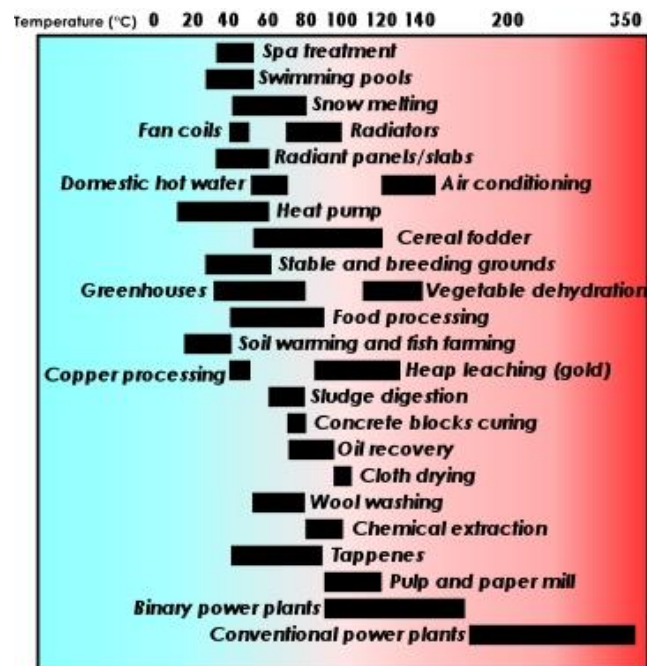

FIGURE 1: Lándal diagram showing different applications of geothermal resources based on temperature

## 3. PRINCIPLE OF OPERATION OF STEAM TURBINE

The production of electricity from a geothermal source is about producing work from heat. Conversion of heat into work is difficult and is limited by the laws of thermodynamics. A part of the heat used has always to be rejected to the surroundings so there is an upper limit of the possible work production from a given heat streams (Valdimarsson, 2014). The Carnot Cycle is usually used as a reference to give the upper limit on the efficiency achievable by a thermodynamic cycle (Equation 1). A Carnot engine is assumed to be operating between two infinitely large heat reservoirs (Figure 2). In reality the heat reservoirs are usually not infinitely large and the supply or rejection will happen at variable temperature. The Carnot efficiency is given as:

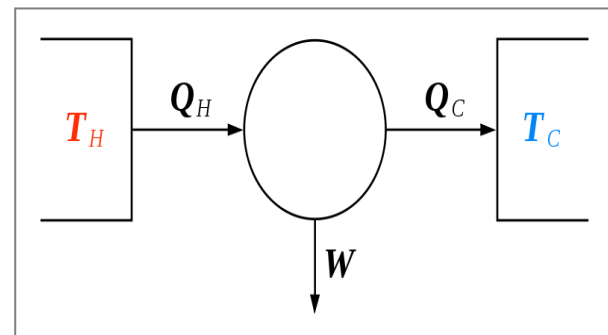

FIGURE 2: Thermal cycle showing heat flow through an energy conversion system

$$\eta_{Carnot} = 1 - \frac{T_C}{T_H} \tag{1}$$

## 4. TYPES OF GEOTHERMAL POWER PLANTS

There are three types of geothermal power plants which are explained briefly below:

- Dry steam power plants that use steam directly from a geothermal reservoir to turn a generator turbine;

- Flash steam plants that utilize steam generated when geothermal fluids boils in a low pressure flashing vessel; and
- Binary power plants that use a secondary working fluid (hence, “binary”) with a much lower boiling point than the source fluid.

Steam cycles utilize high temperature geothermal resources. Binary power plants usually utilize medium to lower temperature wells. Steam turbines operate on the principle of the Rankine Cycle. The steam cycle allows the fluid to boil and then the steam is separated from the brine and expanded in a turbine in the case of a Single Flash Steam Cycle. The brine is then rejected to the environment (re-injected), or it is flashed again at a lower pressure in the case of a Double Flash cycle.

A binary cycle uses a secondary working fluid in a closed power generation cycle. A heat exchanger is used to transfer heat from the geothermal fluid to the working fluid, and the cooled brine is appropriately disposed usually by reinjection. Re-injection of brine as a disposal method has an added advantage of directly recharging the reservoir which is important for sustainability in exploitation of the resource.

#### 4.1 Single flash cycle

Single flash type of geothermal power plants are the most common. The geothermal fluid which is in most cases two phase (a mix of steam and water) is directed to a separator that allows the steam phase to be piped to the plant and the water phase to be piped back into the reservoir via reinjection wells. The steam entering the plant is often run through demister to eliminate any entrained droplets of moisture. A small portion of steam is often directed to a steam jet ejector system and the balance is directed to the turbine. Steam exiting the turbine is directed to a condenser operating at low vacuum. Water from a cooling tower is sprayed inside the condenser condensing the steam back into water. This water is then pumped to the top of the cooling tower for heat dissipation to the atmosphere. A flow sheet for single flash cycle is shown in Figure 3.

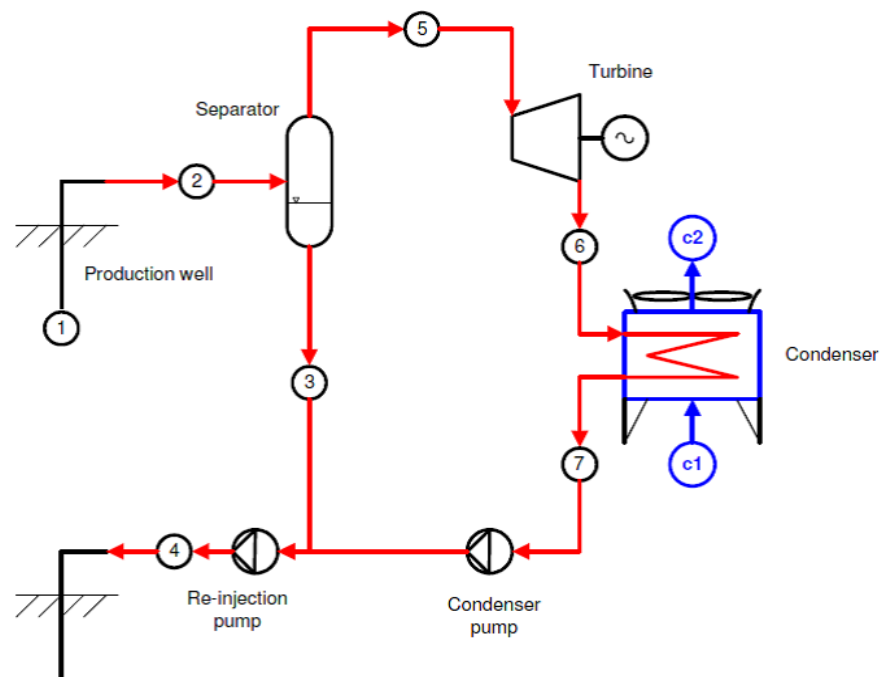

FIGURE 3: Single flash geothermal power plant

#### 4.2 Double flash cycle

A double flash is substantially similar to a single flash plant but the configuration is such that the brine leaving the first separator is directed to another separator at a lower pressure which generates additional steam. Both high pressure steam from the first flash and low pressure steam produced from the second flash are directed to the plant in separate pipelines. The high and low pressure steam can be directed to separate turbines, each designed for the specific inlet pressure available. Alternatively the same turbine can be used with the low pressure steam entering the turbine a few stages later. This turbine is designed

in such a way that the pressure difference over the first stages is the same as the pressure difference between the high and low pressure separators. The schematic of a double flash cycle is shown in Figure 4.

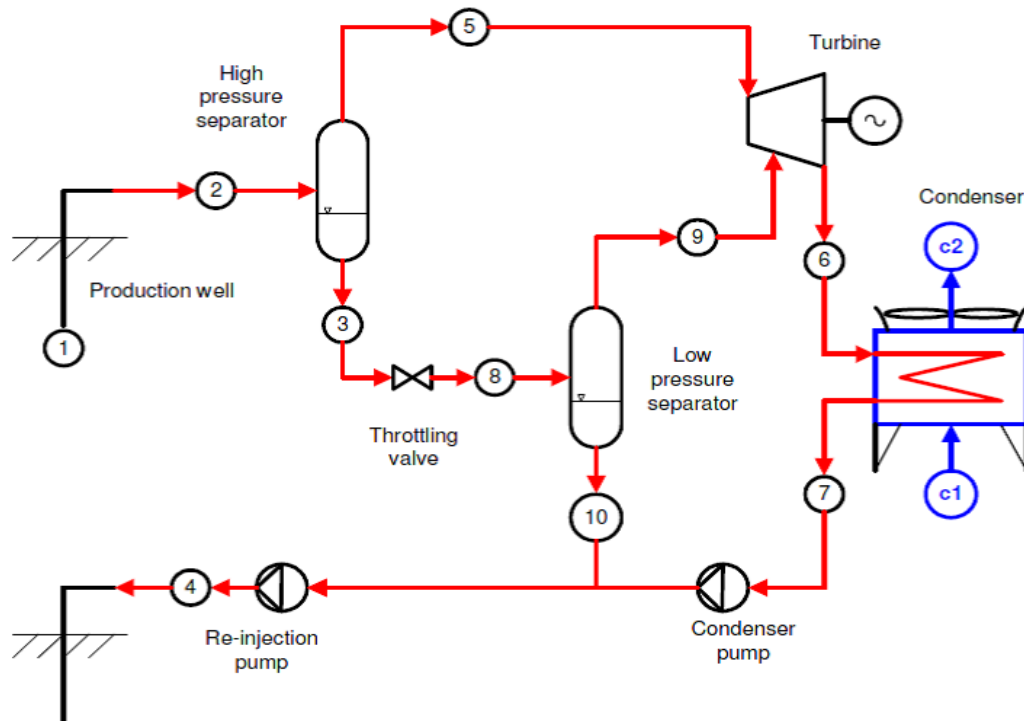

FIGURE 4: Double flash geothermal power plant

### 4.3 Binary power plant

Low to medium temperature geothermal resources are appropriate for binary application. Separated brine or geo-fluid pumped from the well is piped through heat exchangers where heat is transferred to a low boiling point working fluid. The working fluid typically a hydrocarbon or a refrigerant is boiled to form a high pressure vapour. This vapour is then directed to a turbine. The low pressure working fluid leaving the turbine is then condensed by rejecting the heat to the atmosphere. This is accomplished by using water from a cooling tower in a shell and tube condenser or if a source of fresh water is not available for make up an air cooled condenser can be employed. The working fluid is fed back to the heat exchanger using a feed pump and continues circulating in a closed loop. The schematic diagram of a proposed binary power plant in Olkaria utilizing separated brine is shown in Figure 5.

It is possible to have a recuperator to increase a binary power plant efficiency further. What happens in the recuperator is that part of the heat rejected is recovered for input to the power plant. The recuperator increases the temperature of the working fluid at the heat exchanger entry and will therefore lead to higher geothermal fluid exit temperature for the vapourizer.

## 5. POWER PLANT PROCESSES AND MAIN COMPONENTS

The most common power plants are flash type and this chapter will discuss their main components and the entire process of power generation. It mainly consists of a number of interconnected systems that work in tandem to convert the heat energy of the geothermal fluids into electrical energy. The main systems are described below.

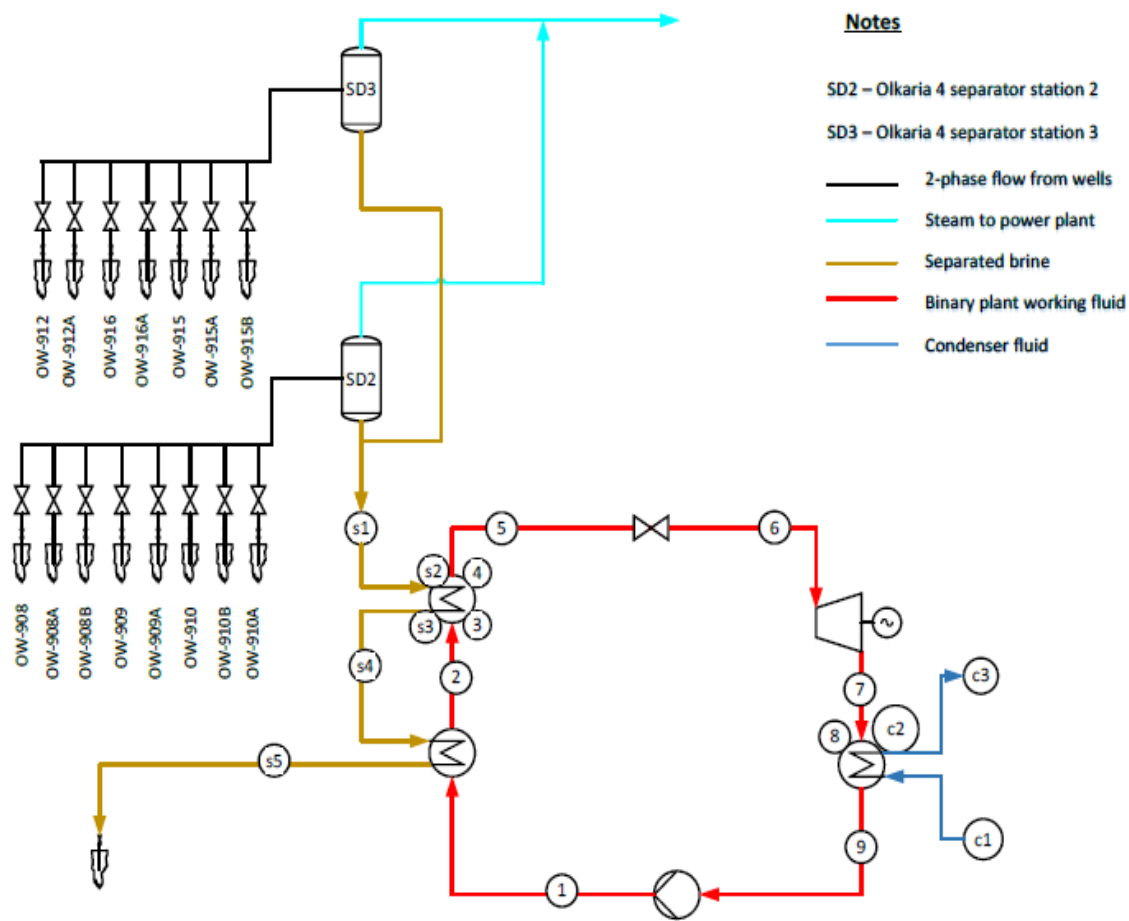

FIGURE 5: Binary power plant

**5.1 The steam supply system – Well(s) and separator(s)**

The steam supply system starts from the well to the turbine inlet. The fluid from the well is received into the steam supply network for onward processing. Where the fluid consists of dry steam only, the steam is transmitted through insulated steam pipes to the turbine. Where the fluid is a mixture of steam and water (brine), the two fluids are separated and the steam transmitted to the turbine.

Steam is normally transmitted using insulated steam pipelines that are designed to minimize pressure and heat losses. Drain pots and steam traps are normally installed along the steam pipelines to collect and remove any condensate that forms on the steam pipeline. Interline pressure controllers are installed at the power plant interface to maintain desired steam pressure and protect the system against unexpected steam pressure surges. The desired steam pressure is set by desired design turbine inlet pressure.

**5.2 Energy conversion system – Turbine and generator**

The steam enters the turbine through governing valves. The steam then expands through the series of alternating rotating and stationary blades through which part of the energy in the steam is transformed into mechanical energy by rotating the turbine rotor. The turbine rotor in turn rotates the generator which transforms the mechanical energy into electrical energy.

### **5.3 Cooling system – Condenser, Cooling tower and circulation pump**

The steam exits the turbine with reduced energy and is exhausted into a condenser where it is condensed into liquid. The condensers can be direct contact (mixing of steam and cooling water) or indirect contact (no mixing). For back pressure turbines, the exhaust steam is rejected into the atmosphere. Back pressure turbines are less efficient and are seldom used (Kapooria et al., 2008).

The condensate formed in the condenser is pumped to a cooling tower where it is cooled down and circulated back into the condenser to provide continuous flow of cold water for condensing the exhaust steam. Cooling towers can be wet type, air type (dry) or hybrid. The choice depends on the need to conserve water and the ambient conditions of the location of the power plant. Excess condensate can be pumped for disposal (re-injection) or for other water uses.

### **5.4 Gas extraction system**

Geothermal steam consists of varying quantities of non-condensable gases. The gases flow with the geothermal steam. When the steam is condensed in a condenser, the non-condensable gases remain and can build back pressure in the condenser. These gases are removed using gas extractors. The extractors can be steam ejectors, vacuum pumps or hybrid of steam ejectors and vacuum pumps.

All the processes above are integrated together and are normally monitored and controlled via a centralized control system.

## **6. WELLHEAD GENERATION CONCEPT**

This is a fairly new technology which entails a small geothermal power plant installed at the wellhead of a geothermal well. The average capacity of a wellhead power plant is 5 MW. The distinct attributes of this technology is that wellhead power plants are designed to match or optimize the production characteristics of an individual well. Secondly the technology reduces the lead time to power generation in comparison to the alternative of having to install larger conventional power plants. Wellhead generators design and installation is modular making it easy to assemble and disassemble and move to a new site if that need arises. Other benefits of wellhead power plants are as follows:

- a. Wellhead plants makes it possible to utilize wells deemed non-commercial for large projects but still have small scale potential.
- b. Through wellhead power plants, wells drilled as part of a large project may be put to use generating power in the short term.
- c. Wellhead power plants projects can be beneficial to attract or catalyze stakeholder support for larger geothermal projects. Once the community and other stakeholders have tasted the benefits of the small power plants they are likely to be more welcoming to the development of larger projects which would bring more benefits.

Although wellhead generators have some advantages over conventional power plants, they also have some disadvantages. Below are some of the disadvantages of wellhead generators:

- a. Small capacities – several wellhead generators are required to match the output of centralized power plants. This translates to increased land requirement and logistical challenges in evacuation of power from the many units.
- b. New technology – the concept is still new and therefore still has some technological challenges.
- c. Higher steam consumption – the steam consumption per MW is higher than conventional larger power plants.



- d. Dependency on an individual well or group of wells on a well pad. When the wells are exhausted, the unit will need to be moved or new wells need to be drilled. Figure 6 below shows a typical layout of a wellhead generator.

## 7. CONCLUSIONS

There is increased drive for clean energy. Geothermal energy is one of the leading sources of green energy. Traditionally conventional large power plants have been used to generate power from geothermal resources but this takes a long time up to 7 years from project inception to actual power production. Lately wellhead power plants have been found to shorten the time that it takes to generate power from a geothermal resource.

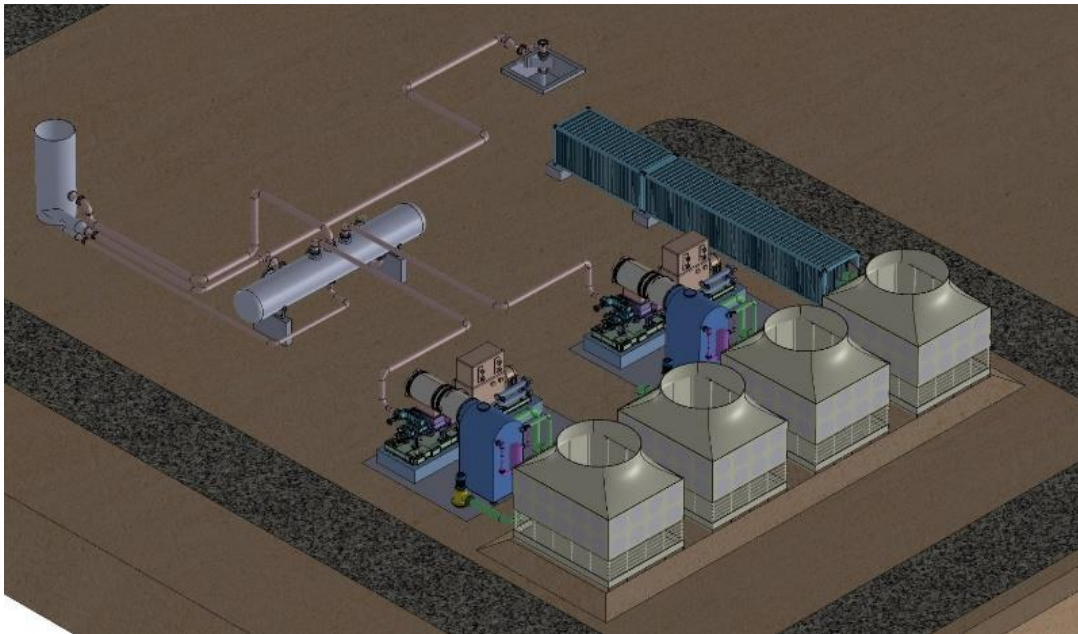

FIGURE 6: Typical layout of a wellhead generator installed by Green Energy Group in Olkaria, Kenya (Green Energy Group, 2011)

## REFERENCES

- Geothermal Education Office, 2011: *Geothermal facts*. Website: <http://geothermal.marin.org/>
- Green Energy Group, 2011: *Presentation of Green Energy Group AS GeoEnergi*.
- Kapooria, R.K., Kumar, S., and Kasana, K.S., 2008: An analysis of power plants working on a Rankine cycle - A theoretical investigation. *Journal of Energy in Southern Africa*, 19, 77-83.
- Valdimarsson, P., 2014: Geothermal utilization – Production of power. Presented at “*Short Course on Utilization of Low- and Medium-Enthalpy Geothermal Resources and Financial Aspects of Utilization*”, organized by UNU-GTP and LaGeo, Santa Tecla, El Salvador, 34 pp.