



## **INTRODUCTION TO GEOTHERMAL DRILLING**

**Miyora Thomas Ongau**  
Geothermal Development Company Ltd  
Nakuru  
KENYA  
*tmiyora@gdc.co.ke*

### **ABSTRACT**

This paper presents all aspects and requirements considered when drilling in a new field. It looks at the equipment and personnel, the statutory requirements to be met before drilling, preparation of the new field before drilling starts, the logistical management of the actual drilling operations, management of the drilling contract and management of the information gathered during the actual drilling. This paper is meant to provide an overview of what is to be done for those planning to start drilling in a new field. Drilling is the last stage of exploration where the existence of the resource is confirmed by actual drilling into the reservoir. After proving the resource, the extent of the resource within a field is determined before finally carrying out production drilling.

## **1. GEOTHERMAL DRILLING**

### **1.1 Introduction**

Drilling is the process of making a hole either vertically or directionally into the earth to tap the resource stored in reservoirs such as oil, gas, water, heat, steam and others. The drilling operation is carried out by a rig which has several operating systems. According to Azar, 2007, drilling for these resources require two major constituents: skilled manpower and hardware systems. In addition to these, hardware and consumable materials such as casings, cement, mud, water and others are needed in the making of the holes (Azar, 2007).

### **1.2 Initial preparations required in a new field**

Prior to any drilling activity, scientific studies are carried out in order to determine the best location for the first exploration well. Those studies are performed by a geoscientific team, which usually is responsible for recommending locations for wildcat wells, while the reservoir team will be responsible, on a later phase, for locating development wells. In either situation, the drilling team will be responsible for the planning and execution of the operation including its budget (cost estimation) and contingency plans (Mitchel, 2011).

Most geothermal resources are located in areas that are difficult to access. Concealed beneath millions of tons of rocks, trapped deep below ground, many thousands of meters under Earth's surface, this energy often is located in areas of very difficult access or even offshore, under very deep waters. Nevertheless, due to its importance in our lives, no matter the location or the depth, in some way we will have to find a means to establish a path between the energy source and the surface (Mitchel, 2011).

The following are necessary civil works that need to be done on a new field before mobilization of drilling equipment.

### 1.2.1 Access roads

For new fields, the construction of roads to access drill sites may involve the destruction of forests and vegetation. The amount of land that is disturbed by road construction during geothermal development may be about 12 hectares when drilling 15 wells. In general, geothermal systems are often located in volcanic environments, where the terrain is steep and access difficult (Maochang, 2001) which implies that for usable access roads to be made, massive earth has to be excavated (Figure 1).



FIGURE 1: Access roads

### 1.2.2 Well pads

A well pad is a relatively flat work area within the geothermal field (surface location) that is used for drilling a well or wells and producing from the well once it is completed (TEEIC, 2015). The well pad is made using earth moving equipment and it usually covers an area of approximately 200-2500m<sup>2</sup>. A well pad may have a recirculation pond which is used to contain water from the drilled hole and will be reused to drill. A well pad also contains a cellar which on which the hole is drilled. Below is a typical figure of a well pad (Figure 2).



FIGURE 2: Well pads

### 1.2.3 Drilling water

Water is required for drilling and if the point of water intake is far, drill pipes have to be installed to transport water to the drilling site. Reservoir tanks have to be constructed to be used for storage (Figure 3). Quite a large amount of water is required for drilling. A typical shallow well requires 1000 m<sup>3</sup> /day,

which may be lost to the formation. A deeper well may require up to 3000 m<sup>3</sup>/day (Brown, 1995) for periods up to several months. Completion testing and injection testing can use up to 10,000 m<sup>3</sup> /day of water. In Iceland up to 40 l/s or 35,000 m<sup>3</sup> of water are required for 24 hours of drilling.

#### 1.2.4 Storage yards/stores

Drilling requires bulky hardware materials as well as consumables. There is therefore a need to have proper storage yards and stores (Figure 4). Hardware materials include casings, bits, drill pipes and many others. Consumables include cement, drilling mud, Lost of Circulation Materials (LCM) and others. Since some materials are affected by weather conditions, it's important to store such materials accordingly in a manner that will maintain their properties.



FIGURE 3: Reservoir tanks



FIGURE 4: Material storage areas

### 1.3 The rotary drilling rig

The rig is a machine that creates holes in the earth's sub-surface. Drilling rigs can be massive housing different systems that work together or they can be small enough to be moved by a single truck.

Currently, rotary drilling is the standard well drilling method for the drilling industry, with almost all operations being performed by rotary-drilling rigs. Rigs will vary widely in size, drilling capability, level of automation, and environment in which they can operate. Nevertheless, the basic rotary-drilling process is the same for all types of rigs as shown in Figure 5.

#### 1.3.1 The drilling systems for a rotary rig

Before drilling commences, the type of a rig to be used has to be selected. The main objective of rig selection is to choose from the available rigs the one that will closely meet the criterion for drilling a hole at the lowest overall cost. The selection process is directly related to evaluation of the rig systems of the available rigs (Azar, 2007).



### I) Power generating system

The power of rotary drilling rigs is usually generated by diesel or gas driven internal combustion engines. This is because most drilling is done in remote locations where grid power is not available. The power that is generated is transmitted to various rig systems by means of mechanical drives such as chains, compounds, torque converters and V-belts or by means of electrical drives using motors. The mechanical transmission systems were used for older rigs (Azar, 2007; Ford, 2004). The electric drive systems of most modern rigs consist of DC/DC systems AC/SCR systems and AC/VFD systems. Each system consists of engine/generator sets, control systems and electric motors (IADC, 2000).

The DC/DC system requires that one or more DC generators be specifically assigned to a DC motor to meet the desired load requirement for the equipment at a controllable speed. The DC motors are used on mud pumps, drawworks and rotary table. In the DC/DC systems we also have AC generators that operate auxiliary functions that require alternating current (Azar, 2007). The DC/DC systems are generally arranged so that each motor can receive power from two or more generator sets to provide backups in case of failure of any engine. The disadvantage of DC/DC system is that the specific assignment of generator sets leads to operating with more engine capacity than the total rig power would justify (Azar, 2007).

Most modern rigs have an AC/SCR system that includes multiple AC generator sets, AC to DC conversion systems and controls connected to DC motors. The advantage of AC/SCR system is

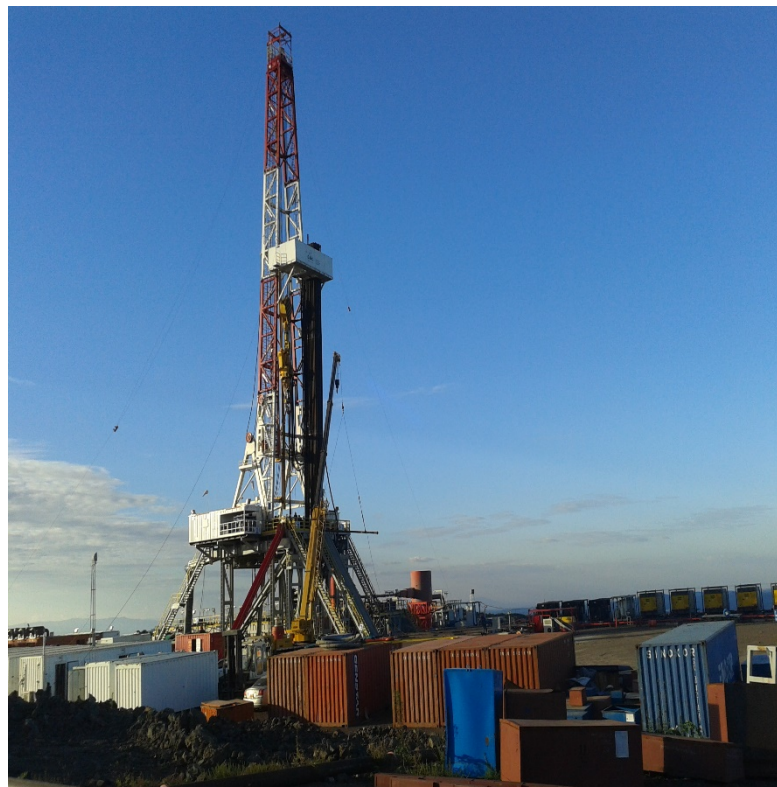
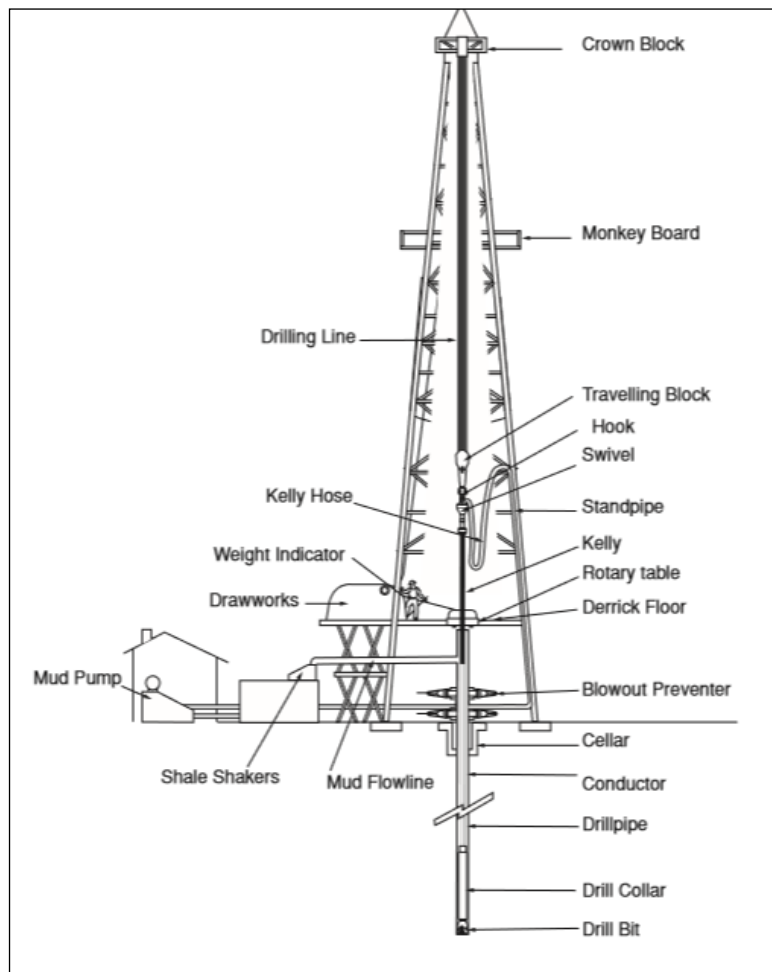

FIGURE 5: Rotary drill rig

that all of the generated AC power is fed to a common bus and converted to DC only as needed (Azar, 2007).

## II) Hoisting system

The function of the hoisting system is to lower and raise equipment into and out of the well. The hoisting system consists of a powerful pulley system. The components of the hoisting system are discussed below:

- Drawworks: It consists of a large revolving drum round which a drilling line is spooled. The other components of the drawworks include the brakes, the transmission and the cathead. The driller controls the drawworks with a clutch, gearing system and the friction brake and electric brake.
- Blocks and drilling line: Blocks refers to the crown block on top of the mast and the travelling block which have sheaves through which the drilling line is reeved. Attached to the travelling block is the hook and the elevators. The hook suspends the drillstring and the elevators are used when running or pulling the drillstring or casings into or out of the hole. The principal function of the blocks and the drilling line is to provide mechanical advantage while raising and lowering extremely heavy loads into the wellbore.
- Deadline anchor and the reserve drum: The deadline anchor is where the drilling line is secured after it has been reeved in the blocks. The deadline anchor and the dead line are stationary. The reserve drum is where the extra length of the drilling line is stored. The figure below shows the diagram of the hoisting system (Figure 6).

## III) The circulation system

The function of the circulation system is to pump the drilling fluid down through the drillstring and up the annulus, carrying the cuttings from the bottom to the surface (Ford, 2004). Tanks are required for storage, mixing and cleaning the mud. The main components of the circulation system are:

- Mud pumps;
- Air compressors;
- High pressure surface connections;
- Drill string;
- Drill bit;
- Return annulus;
- Mud tanks and pit; and
- Mud cleaning equipment.

## IV) Rotary system

The rotary system refers to all components used to turn the drillstring and hence the drill bit at the bottom of the hole as shown below (Figure 7). These include:

- The swivel;
- Kelly/rotary hose;
- The Kelly;
- The rotary table;
- The drillstring; and
- Downhole motors.

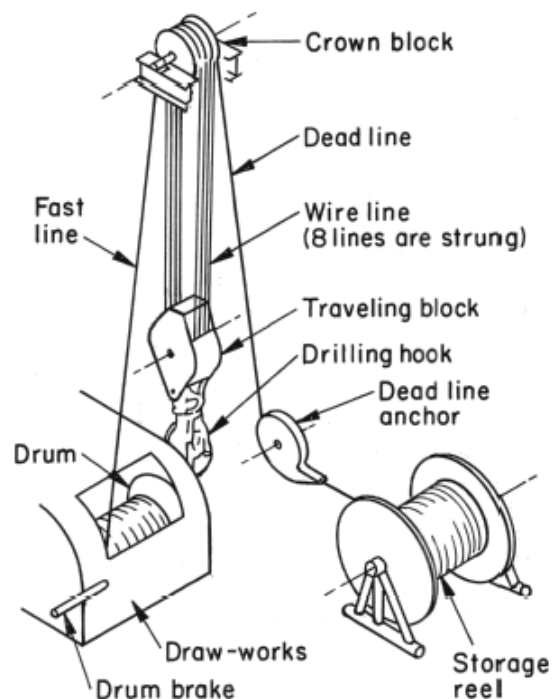

FIGURE 6: The hoisting system (Azar, 2007)

## V) Blowout control system

The primary function of the well control system is to prevent the uncontrolled flow of formation fluids from the wellbore as a result of a kick (Azar, 2007). A kick occurs when drilling is done in a permeable formation and the pressure from the pores of the formation is greater than the pressure exerted by the column of the drilling fluid resulting in formation fluids entering the wellbore and displacing the drilling fluid (Ford, 2004). Failure to contain a kick will result to a blow-out which results to higher drilling costs, waste of natural resources, possible loss of human life and damage to equipment.

The primary well control is achieved by ensuring that the hydrostatic drilling fluid pressure is sufficient to overcome the formation pressure. The well control system requirement is to safely permit shutting in the well at surface, controlling removal of formation fluid from the wellbore, pumping high density mud into the hole, and stripping the drill pipe into or out of the hole (Azar, 2007).

The well control system is designed to:

- Detect a kick;
- Close in the well at surface;
- Remove the formation pressure from the well; and
- Make the well safe.

The basic component of the well control system is the blowout preventer (BOP) stack shown in the figure which comprises of the following equipment (Figure 8):

- Annular preventer;
- Ram preventers;
- Spools;
- Internal preventers;
- Casing head;
- Flow and choke lines and fittings;
- Kill lines and connections;
- Mud and gas handling facilities; and
- Accumulators.

## VI) Drilling data acquisition and monitoring system

The purpose of this system is to aid the driller and to monitor, analyse, display, record, and retrieve information regarding drilling operations in order to detect drilling problems for early remedial action. The parameters

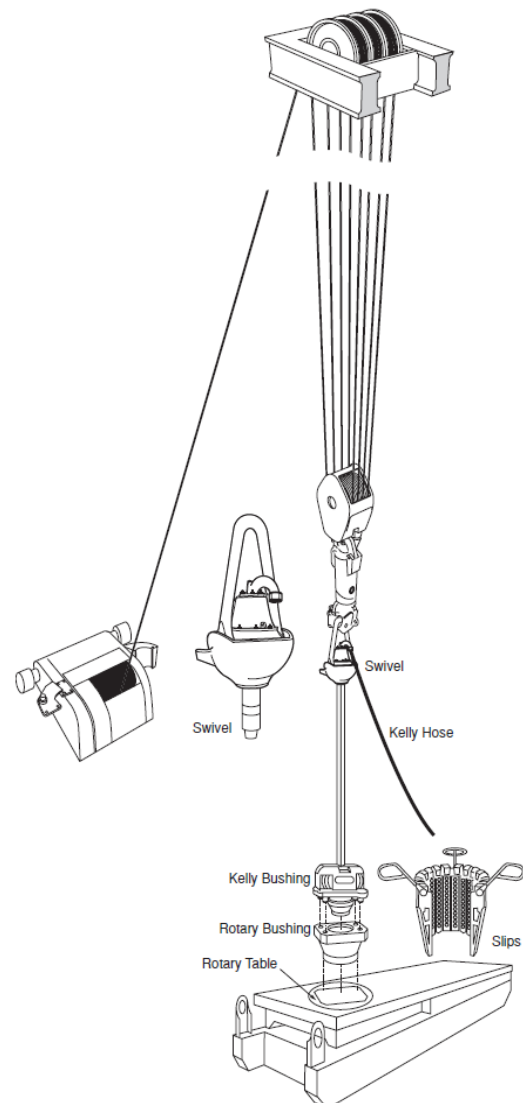

FIGURE 7: The rotary system (Ford, 2004)



FIGURE 8: BOP Stack

monitored are drilling rate, hook load, hole depth, pump pressure, flow rate, torque, rotary speed, mud tank levels, pump strokes, weight on bit, and hoisting speed (Azar, 2007). The driller must be aware of how the drilling parameters are changing and their implications (Ford, 2004). The data is stored on the hard disk of the computer system. This information can later be retrieved for the purpose of analysis and research.

#### **1.4 Personnel organization and contract management**

Drilling a well requires many different skills. Depending on the nature of management of the drilling project that is in place, the personnel that work at the drilling rig will differ as per the number of companies involved with the project. The company who manages the drilling and/or production operations is known as the operator. The drilling contractor is the company employed to actually drill the well and it owns the rig and employs and trains the personnel that operate the rig. In the course of drilling the well, specialised skills and equipment such as for directional drilling, cementing, logging, surveying, fishing etc. will be required and these are commonly provided by service companies but sometimes in-house by the drilling contractor. The service companies contract their tools and personnel to the operator generally on day rate basis (Ford, 2004).

The types of contracts for drilling services range from day-rate contracts to turnkey contracts. In Iceland, geothermal drilling operations are executed under contract structures which are predominantly based on a metre-rate and are referred to as being integrated as it encompasses all services and materials. In New Zealand, Kenyan and Indonesian geothermal drilling operations, the contracts are predominantly day-rate (unit time rate contracts) (Hole, 2006). The most common type of contract is day-rate contract. The drilling contractor follows a detailed Drilling Program prepared by the operator and the drilling contractor provides the drilling rig and personnel to drill the well. The drilling contractor is paid a fixed sum of money for each day spent in drilling the well. All consumables, transport and drilling services are provided by the operator (Ford, 2004).

In the turnkey contract, the drilling contractor comes up with the drilling program, provides transport, services and consumables and charges the operator a fixed sum of money for the whole project. The role of the operator is to specify the drilling targets, the evaluation procedures and to establish the quality controls for the final well (Ford, 2004).

The operator will generally have a representative at the rig called a “company man” who ensures that drilling is carried out according to the drilling program, makes decisions affecting the well drilling and organizes supplies of consumables to the rig. The company man liaises with the drilling superintendent who is based in the operator’s office. The operator may also have personnel such as the drilling engineer and geologist at the rig.

The drilling contractor has a toolpusher at the rig who is in overall charge of the rig and co-ordinates the drilling crew to ensure that drilling progresses as planned. The drilling crew includes: the driller, the derrickman, the floormen/roughnecks, mechanic, electrician, crane operator, and roustabouts.

The service company personnel are at the rig when their services are required. Such personnel include cementing engineers, directional drilling engineer, mud engineer, etc. Figure below shows the personnel involved in drilling a well (Figure 9).

#### **1.5 The camp for personnel**

Drilling is a 24-hour operation and the personnel usually work on a 12-hour shift. This requires the personnel to be housed within the drilling site. The camp provides all the services to make the drilling and support crew a comfortable life. These services include accommodation, catering, laundry, recreation and security among others (Figure 10).

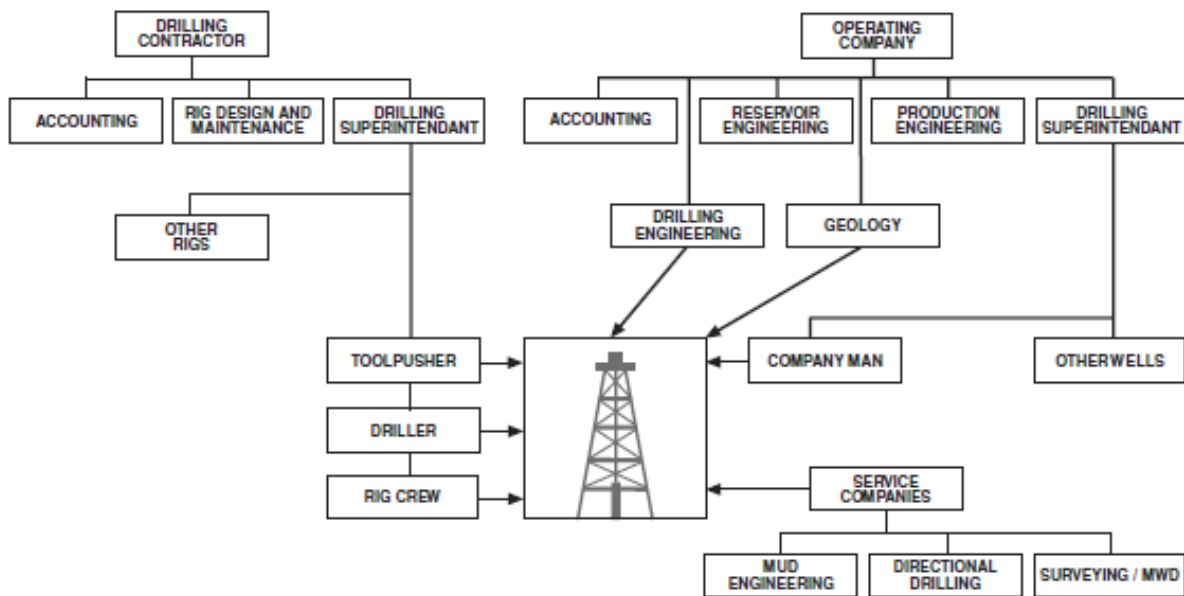

FIGURE 9: Personnel involved in drilling (Adapted from Ford, 2004)



FIGURE 10: Personnel camp

### 1.6 The licensing

Before companies carry out any exploration work, they need to apply for licences. The licence that needs to have been acquired before exploration drilling is done in Kenya is the Geothermal Resources Licence. This Licence is issued by the Ministry of Energy for a period of 5 years. The Minister may extend time to the licensee for complying with the terms and conditions of any licence upon such terms and conditions as he may think fit.



### 1.7 Services required for a successful drilling

The services required in drilling operations are best understood by a brief description of a typical drilling process as shown in the figure below (Figure 11).

The first casing is the 30" conductor casing and is usually installed to prevent loose surface formation from collapsing into the main hole. The second 20" casing is the surface casing which is put in a 26" hole and then cemented to the surface. The third casing is the 13-3/8" anchor casing which is put in a 17-1/2" hole. The casing is then cemented to the surface. The fourth casing is the 9-5/8" casing that is put in a 12-1/4" hole and then cemented to the surface. The final casings in geothermal wells is the 7" casing which is usually slotted and is either hung in the 9-5/8" casing or set on bottom of the hole (Ford, 2004).

The Services required to perform the above services are:

- Cementing Service: Involves pressure pumping cement slurring to hold the casings in place and also to plug the hole to consolidate the formation
- Directional drilling services: Important when doing directional wells
- Fishing Services: This is the process of retrieving equipment lost in the hole while drilling. Fishing services are also required when the drill pipe is stuck.
- Rig move services: For moving the rig from one point to another.
- Equipment maintenance services: To ensure that the equipment are in good working condition to avoid non-productive time.
- Inspection services: Inspection of the drill string and the lifting equipment.

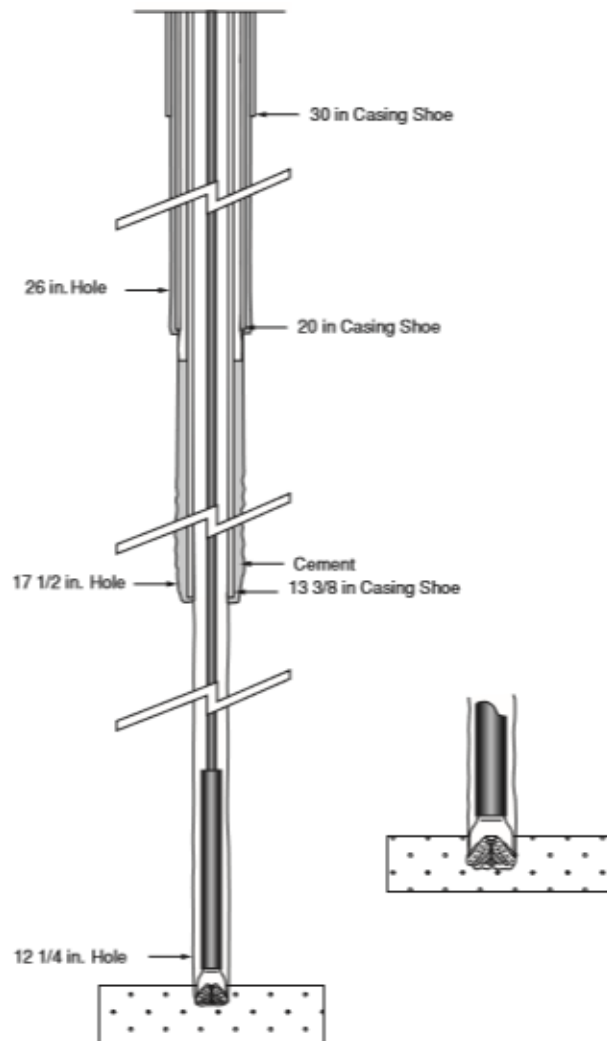

FIGURE 11: Typical drilling process

## 2. CONCLUSION

For drilling to be successfully done in a new field, proper planning needs to be done. Acquisition of the right rig type is the first step and thereafter coordinating all disciplines to work together as a team.

## REFERENCES

Azar, J.J., and Samuel, G.R., 2007: *Drilling Engineering*. PenWell Corporation. 500 pp.

Brown, K.L., 1995: Impact on the physical environment. In: Brown, K.L. (convenor), *Environmental aspects of geothermal development. World Geothermal Congress 1995, IGA pre-congress course, Pisa, Italy*, 39-55.

Ford, J., 2004: *Drilling Engineering*, Herriot-Watt University, Department of Petroleum Engineering. 540 pp.

Maochang H., 2001: Possible environmental impacts of drilling exploratory wells for geothermal development in the Brennisteinsfjöll area, SW-Iceland. *United Nations University, Geothermal Training Programme. Reykjavík, Iceland 2007*. 32 pp

Mitchel, R.S., and Miska, S.Z., 2011: *Fundamentals of drilling engineering*, SPE textbook series Vol.12

TEEIC- <http://teeic.indianaffairs.gov/glossary/glossary.htm#200>